

**DZQ/DZS/DZF..B standard (pravé otáčky, 1 rychlost)**

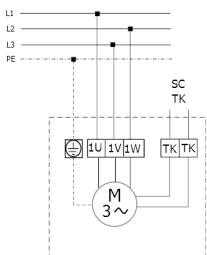

SC - ochranný kontakt  
TK - termokontakt

**DZQ/DZS/DZF..B standard (levé otáčky, 1 rychlost)**



SC - ochranný kontakt  
TK - termokontakt

**DZQ / DZS..B s 5-stupňovým trafem TRV..**

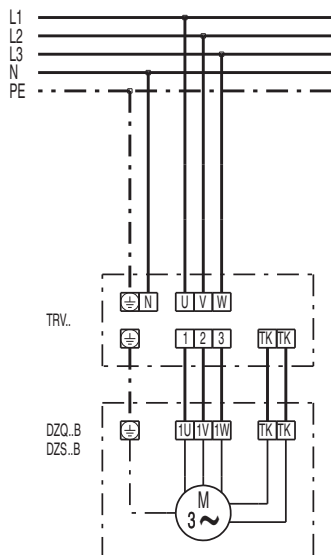

**DZQ / DZS..B 1 otáčky s ochranou motoru MV 25**

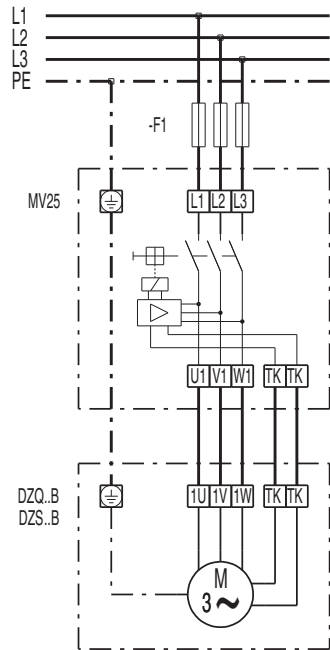

**DZQ / DZS..B s ochranou motoru MV 25 a reverz. přepínačem W 1/WU 1**

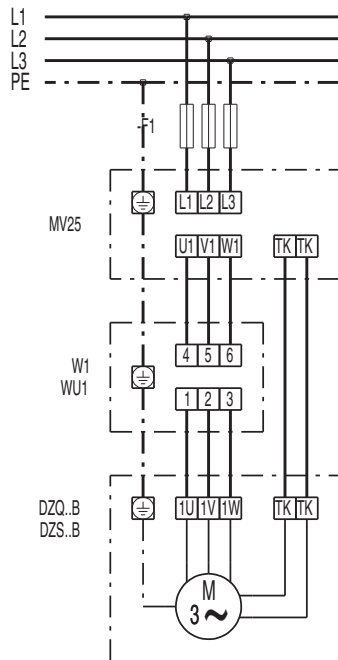

**DZQ / DZS..B s 5-stupňovým trafem TR**

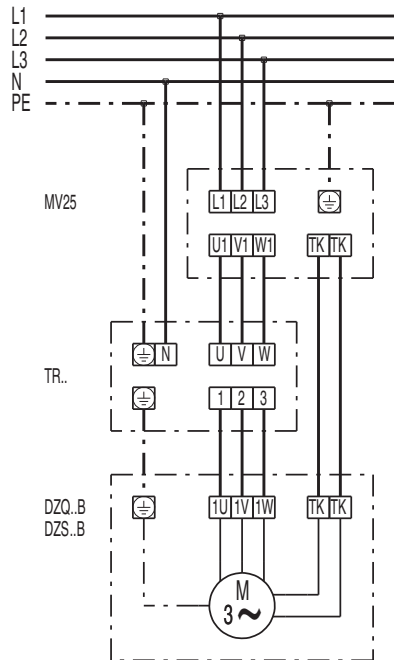

# DZQ 20/2 B

**DZQ / DZS..B s 5-stupňovým trafem do rozváděče TR..S, 5-stupňovým spínačem DSS 20 a ochranou motoru MV 25**

