

AKE 100



Short description

Automatic cellar dehumidification, DN 100, air volume 92 m³/h

Application examples

Cellar and/or cellar room, Utility room, Drying room, Utility room

Article number 0084.0220

Technical data

Air flow volume	92 m ³ /h
Rotating speed	2.500 1/min
Speed controllable	–
Reversing capacity	–
SEC average	-24,18 kWh/(m ² *a)
Type of voltage	Alternating current
Rated voltage	230 V
Frequency	50 Hz
Nominal output	8 W
Stand-by power consumption	2 W
I _{max}	0,06 A
Degree of protection	IP X4
Mains cable	5 x 1,5 mm ²
Installation site	Wall
Type of installation	Surface-mounted
Installation position	any
Material	Synthetic material
Colour	Traffic white, similar to RAL 9016
Weight	0,85 kg
Weight including packaging	1,13 kg
Shutter	none
Nominal size	100 mm
Cable length	1 m
Width	159 mm
Height	159 mm
Depth	130 mm
Width with packaging	225 mm
Height with packaging	225 mm
Depth with packaging	200 mm

AKE 100

Wall thickness	max. 0.85 m (if a 1 m length of cable isn't sufficient, please also order the 6m sensor cable)
Airstream temperature at I_{Max}	40 °C
Sound pressure level	32 dB(A) (Distance 3 m, Free-field conditions)
Packing unit	1 piece
Range	A
GTIN (EAN)	4012799842200

Characteristic curve

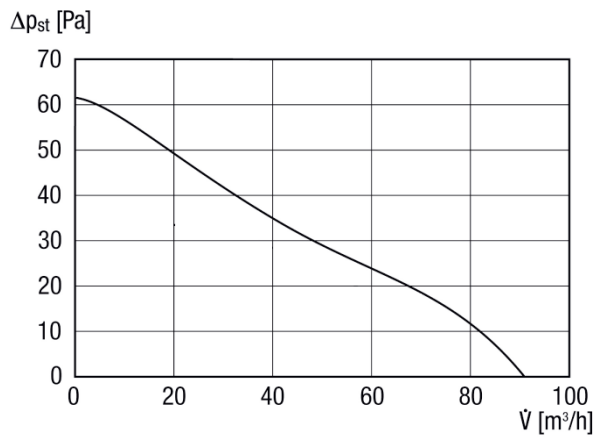

AKE 100

Dimensioned drawing [mm]

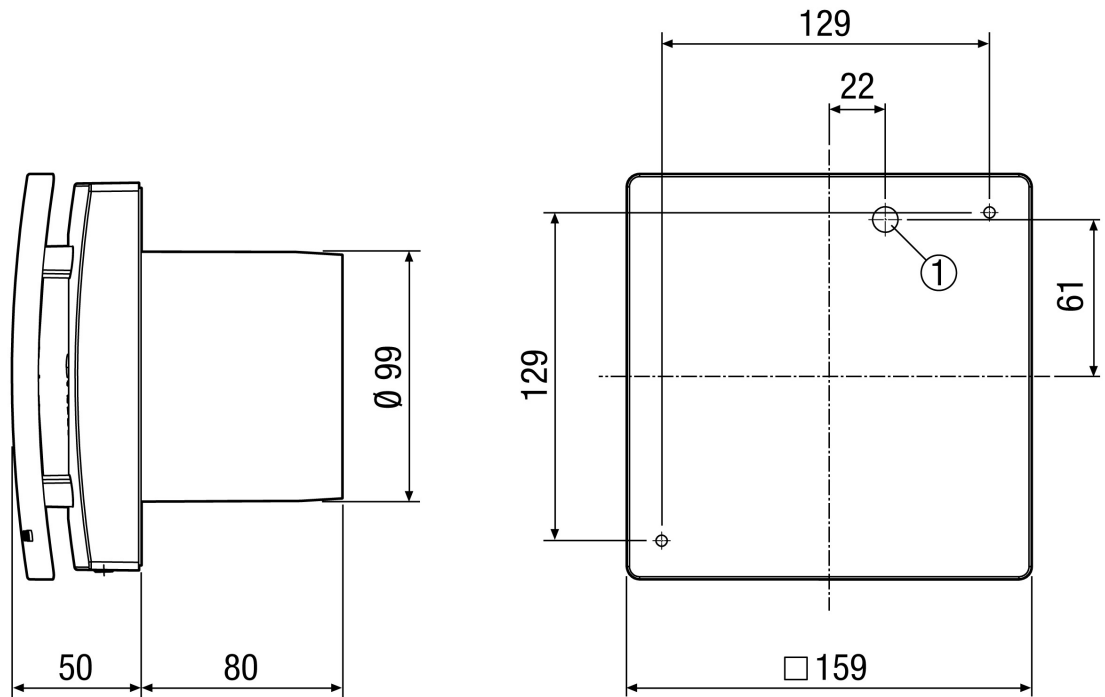

① Cable entry

Dimensioned drawing [mm]

External shutter (included in the scope of delivery)

