

Duo AO-SE



Short description

Installation kit for decentralised ventilation unit with Duo AO-SE heat recovery, comprising ventilation unit with internal cover, highly-efficient enthalpy cross-counterflow heat exchanger, EC centrifugal fans in outside air and outgoing air, 2 x G3 filter, volumetric flow range from 20 to 60 m³/h, model: Attachment to the wall, accessories needed: Duo A-SR shell installation kit and combination wall socket coated in stainless steel (Duo KWS E) or powder-coated in white, similar to RAL 9010 (Duo KWS W)

Application examples

all rooms up to 50 m², Individual rooms, Hotel rooms, Student apartment, Bedrooms

Article number 0095.0560

Technical data

Number of ventilation levels	3
Air flow volume	20 m ³ /h / 30 m ³ /h / 60 m ³ /h (with Duo A-SR shell installation kit)
SEC average	-32,22 kWh/(m ² *a)
Energy efficiency class	B
Type of voltage	Alternating current
Rated voltage	230 V
Frequency	50 Hz/60 Hz
Maximum power consumption	4,2 W / 5,7 W / 16,6 W
Stand-by power consumption	1.5 W
I _{max}	0,2 A
Degree of protection	IP 00
Electrical plug-type connection	Terminal / plug
Installation site	Outside wall
Type of installation	Surface-mounted
System type	Decentralised
Housing material	Sheet steel, powder coated
Heat exchanger material	Synthetic material
Inner coating material	Plastic EPP
Colour	White, similar to RAL 9010
Weight	21 kg
Weight including packaging	22 kg
Type of filter	Outside and exhaust air filter
Filter class	G3 (optional M6)
Connection diameter	90 mm
Width with packaging	575 mm
Height with packaging	975 mm
Depth with packaging	310 mm
Airstream temperature at I _{Max}	-15 °C up to 60 °C
Ambient temperature	10 °C up to 40 °C

Duo AO-SE

Max. degree of heat provision in accordance with DIN EN 13141-7 (A7)	91,4 %
Heat exchanger construction type	Enthalpy cross-counterflow
Permissible humidity in installation room	70 %
Antifreeze circuit	yes
Filter monitoring	with time control
Sound pressure level	30 dB(A) / 33 dB(A) / 42 dB(A) (Distance 1 m, free-field conditions)
Rated max. element normal difference in noise level $D_{n,w}$	43 dB (measured with combination wall socket, 52 dB measured with soffit element)
Rated sound reduction index $R_{w,R}$	18 dB (measured with combination wall socket, 27 dB measured with soffit element)
Packing unit	2 x G3
Range	K
GTIN (EAN)	4012799955603

Characteristic curve

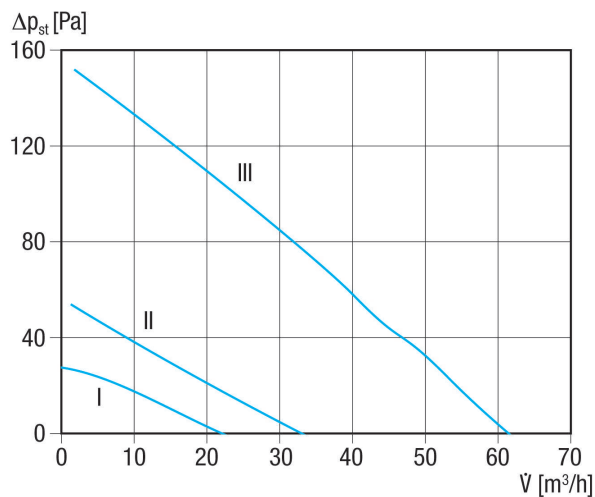

Duo AO-SE

Dimensioned drawing [mm]

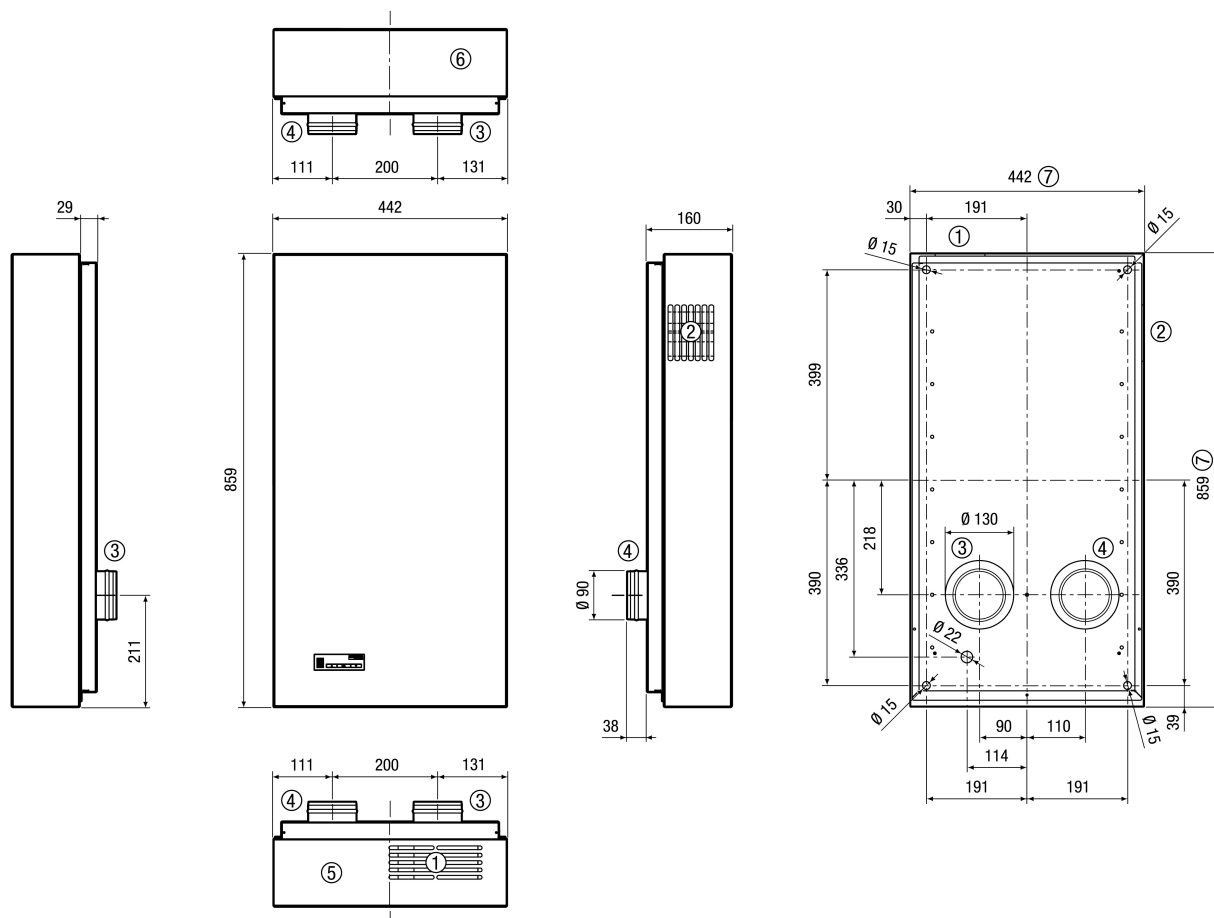

- ① Supply air
- ② Exhaust air
- ③ Outgoing air
- ④ Outside air
- ⑤ View from above
- ⑥ View from below
- ⑦ Unit cover, external dimensions