

KFD 9030



Short description

Sound-insulated Flatbox for supply air with diagonal fan, shutter, air filter and water-air heater, channel size 900 mm x 300 mm

Article number 0080.0964

Technical data

Air flow volume	3.880 m³/h
Rotating speed	2.800 1/min
Air direction	Ventilation
Speed controllable	✓
Rated voltage	230 V
Nominal output	580 W
I _{max}	3,4 A
Degree of protection	IP 43
Operator unit degree of protection	IP 00
Weight	72 kg
Weight including packaging	72,6 kg
Filter class	F5
Channel dimension	900 mm x 300 mm
Width	530 mm
Height	367 mm
Depth	967 mm
Width with packaging	1.042 mm
Height with packaging	377 mm
Depth with packaging	772 mm
Airstream temperature at nominal current	55 °C
Airstream temperature at I _{Max}	55 °C
Packing unit	1 piece
Range	K
GTIN (EAN)	4012799809647

KFD 9030

Sound power level in octave range

	63 Hz	125 Hz	250 Hz	500 Hz	1 kHz	2 kHz	4 kHz	8 kHz	Total
L_{WA2}, high (dB(A))	–	51	53	51	47	46	45	38	58
L_{WA5}, high (dB(A))	–	59	63	72	70	66	60	49	75
L_{WA6}, high (dB(A))	–	65	72	78	80	77	71	64	84

L_{WA2}= housing sound power level in dB.
 L_{WA5}= free inlet sound power level in dB.
 L_{WA6}= free outlet sound power level in dB.

Characteristic curve

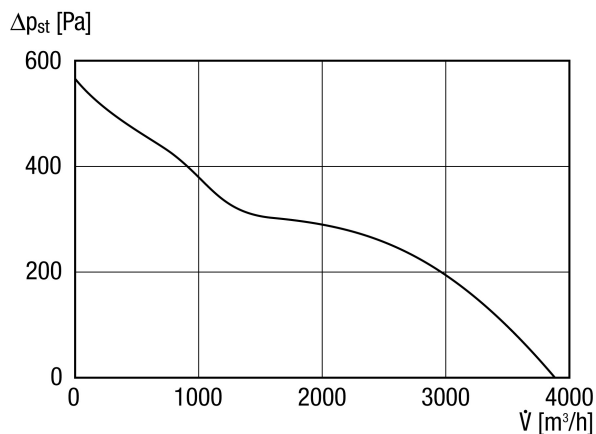

Characteristic curve Water pressure losses in the heat register

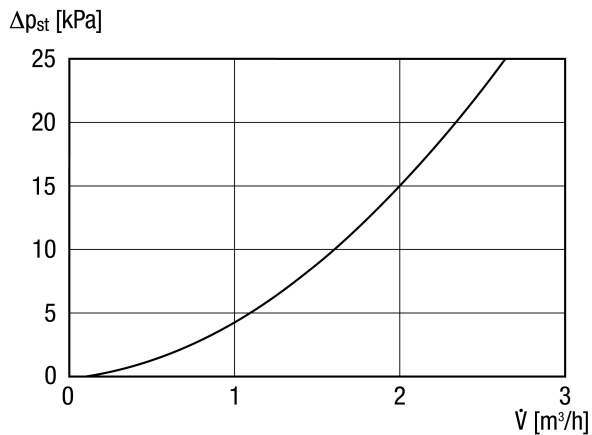

KFD 9030

Dimensioned drawing [mm]

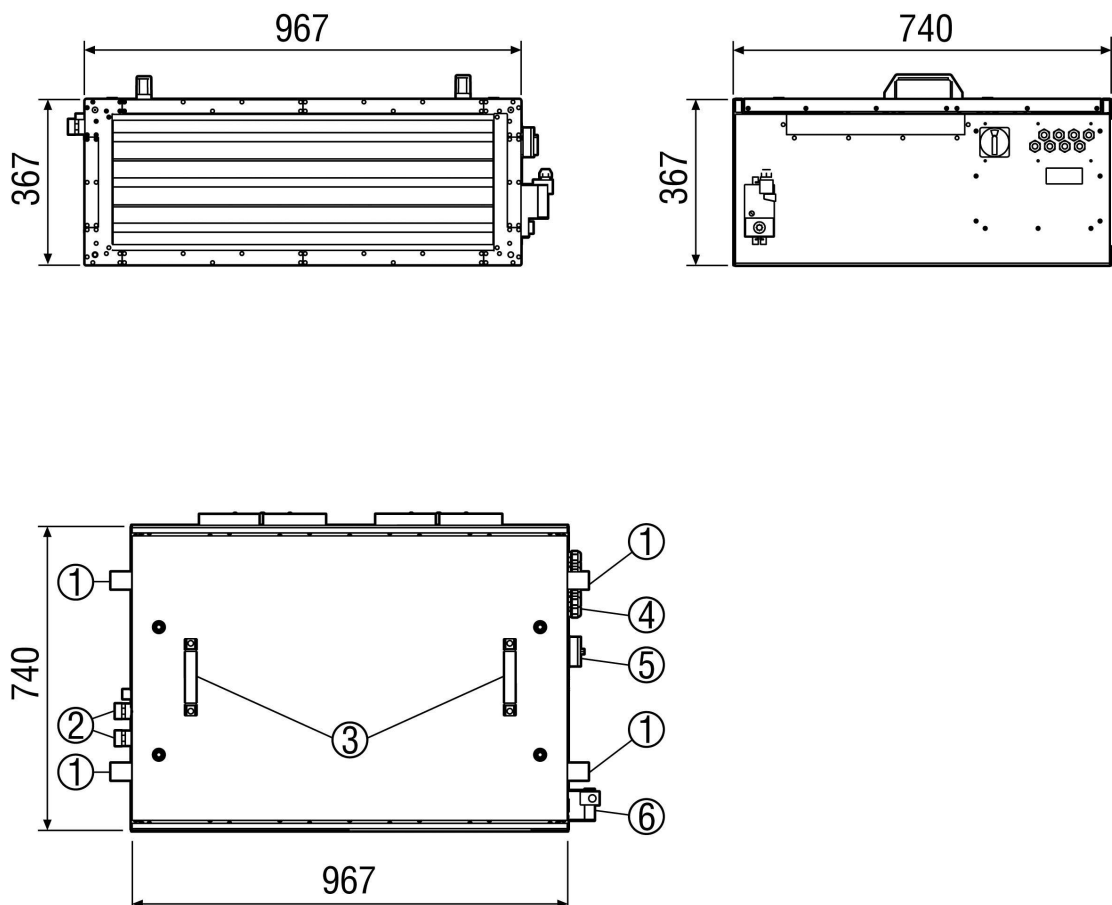

- ① Mounting bracket (variable position)
- ② Warm water connection for water-air heater 3/4" AG (connection also possible on opposite side)
- ③ Mounting handle
- ④ Electrical connections
- ⑤ Terminal box for fan
- ⑥ Servomotor shutter