

WS 75 Powerbox S



Short description

WS 75 Powerbox S ventilation unit with heat recovery. DN 100 outgoing and outside air connections on side. The Powerbox contains the high-quality, RLS G1 WS room air control made of glass, a highly-efficient enthalpy cross-counterflow heat exchanger, EC centrifugal fans with constant volumetric flow in outside air and outgoing air, temperature and humidity monitoring, 2 ISO Coarse 80 % (G4) filters, volumetric flow range from 20 to 70 m³/h, model: Installation on the (suspended) ceiling or interior wall, accessories needed: SVR 100 plug connector

Application examples

all rooms up to 60 m², Individual rooms, Hotel rooms, Student apartment, Bedrooms

Article number 0095.0645

Technical data

Model	Outgoing and outside air connections on side
Number of ventilation levels	4
Air flow volume	20 m ³ /h / 70 m ³ /h ((Factory 20 / 30 / 40 / 50 m ³ /h))
SEC average	-40,82 kWh/(m ² a)
Energy efficiency class	A
Type of voltage	Alternating current
Rated voltage	230 V
Frequency	50 Hz/60 Hz
Maximum power consumption	5,2 W / 6,1 W / 8,3 W / 11,5 W
Stand-by power consumption	< 1 W
I _{max}	0,2 A
Degree of protection	IP 00
Electrical plug-type connection	Terminal
Installation site	(Suspended) ceiling / Inside wall
Type of installation	Recessed-mounted
System type	decentralised/centralised
Housing material	Plastic EPP
Heat exchanger material	Synthetic material
Inner coating material	EPP
Colour	traffic white RAL 9016 (matt fine structure)
Weight	17,5 kg
Weight including packaging	20,5 kg
Type of filter	Outside and exhaust air filter
Filter class	ISO Coarse 80 % (G4) / optional ISO ePM1 60 % (F7)
Connection diameter	100 mm / 75 mm
Width	640 mm
Height	1.040 mm
Depth	155 mm
Width with packaging	660 mm

WS 75 Powerbox S

Height with packaging	1.060 mm
Depth with packaging	180 mm
Airstream temperature at I _{Max}	-15 °C up to 60 °C
Ambient temperature	10 °C up to 40 °C
Degree of heat provision	93 % / at 20 m³/h
Heat exchanger construction type	Enthalpy cross-counterflow
Humidity recovery with enthalpy heat exchanger in accordance with DIN EN 13141-7 (A2)	75 %
Permissible humidity in installation room	80 %
Bypass	No
Frost protection	optional
Enthalpy heat exchanger	yes
Antifreeze circuit	yes
Summer circuit	ECO exhaust air / ECO supply air
Filter monitoring	with time control
Humidity control	integrated
CO ₂ regulation	WS 75 CO2, PP 45 CO2, SKD
Air quality control (optional)	WS 75 VOC, PP 45 VOC
KNX connection (optional)	K-SM
MODBUS interface	integrated
Control unit included in scope of delivery.	RLS G1 WS, APP
EnOcean wireless integration (optional)	yes
Mobile control	yes
Sound pressure level	15 dB(A) / 16 dB(A) / 19 dB(A) / 20 dB(A) (Flush mounting, distance of 1 m free-field conditions)
Rated max. element normal difference in noise level D _{n,w}	56 dB (measured with backflow preventer and combination wall socket, 62 dB measured with backflow preventer and soffit element)
Rated sound reduction index R _{w,R}	31 dB (measured with backflow preventer and combination wall socket, 37 dB measured with backflow preventer and soffit element)
Packing unit	1 piece
Range	K
GTIN (EAN)	4012799956457

Sound power level in octave range

	63 Hz	125 Hz	250 Hz	500 Hz	1 kHz	2 kHz	4 kHz	8 kHz	Total
L_{WA2}, 50 m³/h (dB(A))	13	21	20	23	22	15	14	13	28,4
L_{WA5}, 50 m³/h (dB(A))	16	22	26	26	24	13	14	13	31,2
L_{WA6}, 50 m³/h (dB(A))	17	20	26	29	27	13	14	13	32,7

L_{WA2}= housing sound power level in dB.

L_{WA5}= free inlet sound power level in dB.

L_{WA6}= free outlet sound power level in dB.

WS 75 Powerbox S

Characteristic curve

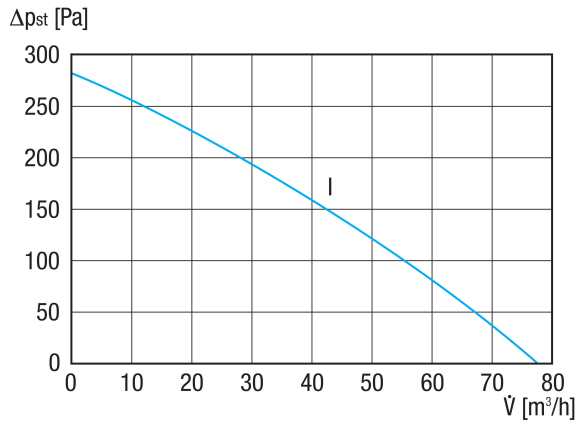

Dimensioned drawing [mm]

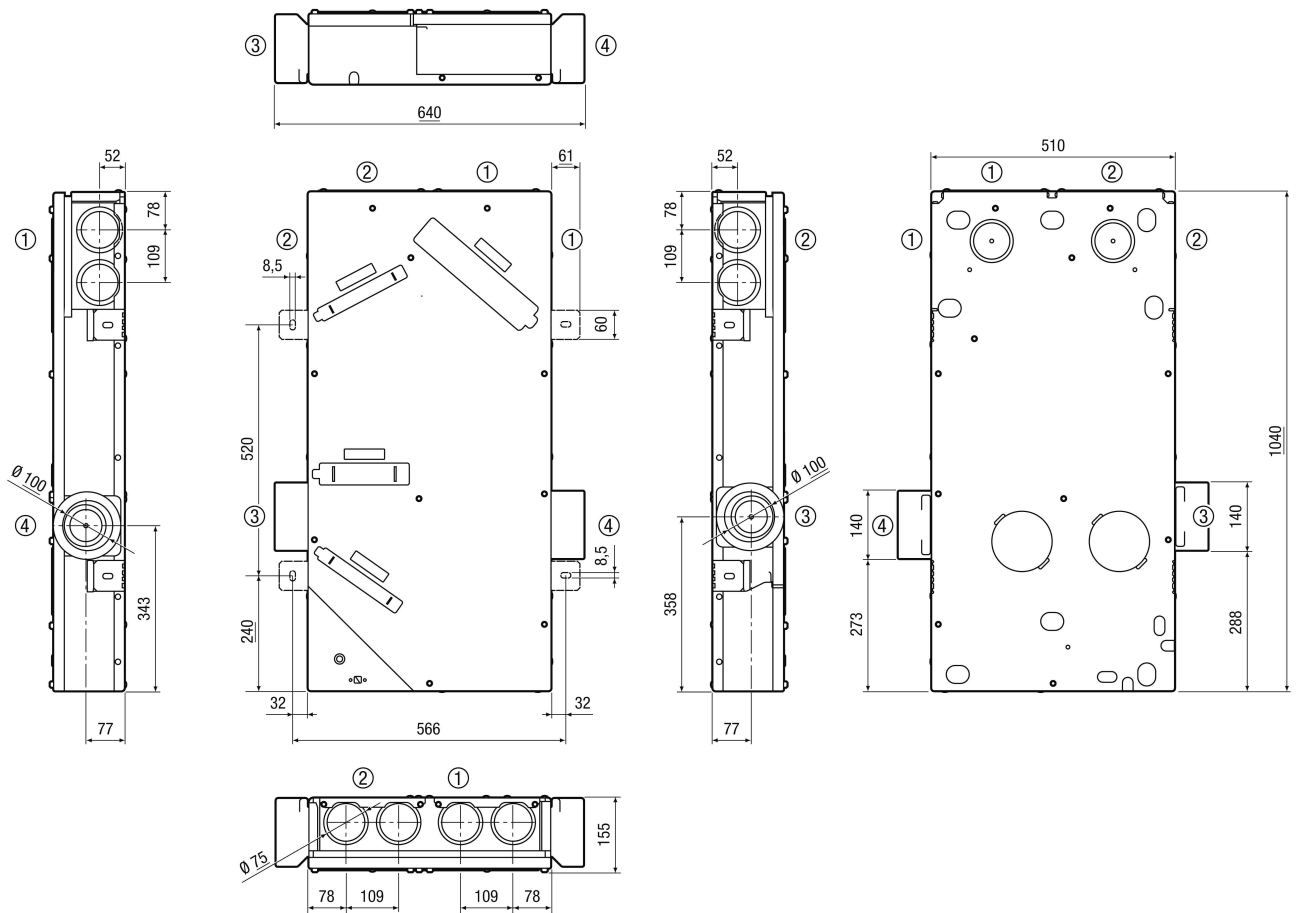

- ① Supply air
- ② Exhaust air
- ③ Outside air



WS 75 Powerbox S

④ Outgoing air