

INSTALLATION INSTRUCTIONS

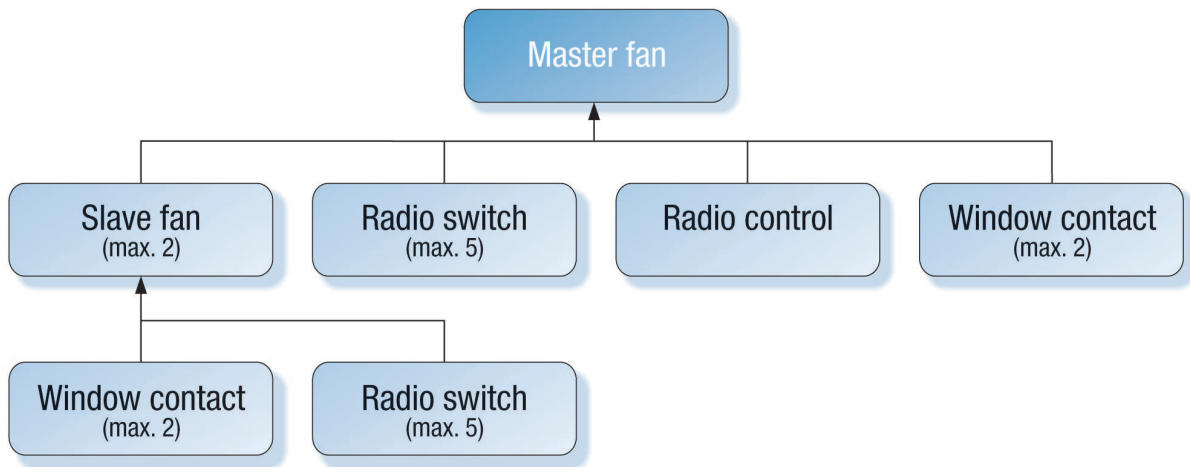

ECA 150 ipro KRCH

Maximum number of components



- Several points should be noted when planning the MAICOsmart system. Radio communication is very reliable. But radio signals can be restricted by metal plates or armouring iron in the building shell. When positioning the radio components, therefore be sure that there are no metallic objects near the installation site.
- The transmitters must not be attached to metallic surfaces. Before fitting the radio components, you should therefore test whether the intended installation location is suitable. We would recommend using a field measuring device to establish the right type of installation and to check the radio signals.

ECA 150 ipro KRCH



- ① Metal obstacle
- ② Master fan
- ③ Slave fan
- ④ Radio control

■ In the diagram, the slave fan functions as a repeater and forwards the radio signal to the master fan. Direct communication between the radio control and master fan is not possible in this example.

Positioning the ALD outside air openings

- We recommend positioning the ALDs in the external wall or in the top window frame.
- The ALDs are fitted in rooms requiring supply air.
- Be sure to fit the ALDs over radiators wherever possible. This prevents draughts.

Positioning the radio control

- Several criteria should be noted when selecting an installation location for the radio control:
 - Since the radio control is powered by solar cells, it must be positioned in a bright spot in the room.
 - It must be positioned in a dry place.

INSTALLATION INSTRUCTIONS

ECA 150 ipro KRCH

Wall mounting of ECA small room fans

Please note the following points when fitting ECA 100 ipro, ECA piano, ECA 100, ECA 120 and ECA 150 series model fans in a wall:

- A minimum distance between the wall and the ceiling must be observed when preparing the wall breakthrough, see diagram.
- Fit a wall sleeve.
- Feed in the connecting cable for surface or recessed mounting.
- ECA 100 ipro and ECA piano only available as recessed-mounted fans.
- Secure the fan using screws during installation.
- The AP shutter prevents cold air from entering when the fan is switched off. Not required with ECA piano and all versions with electrically-operated internal shutter.

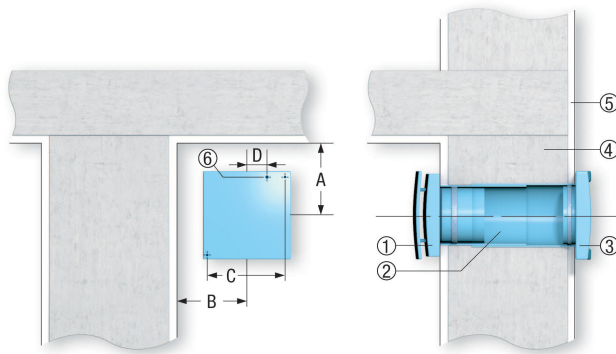

- ① ECA fan
- ② WH wall sleeve
- ③ AP outside shutter
- ④ Masonry
- ⑤ Plaster
- ⑥ Cable entry

Ceiling installation with roof cowl

Please note the following points when fitting ECA 100 ipro, ECA piano, ECA 100, ECA 120 and ECA 150 series model fans in a ceiling in ventilation systems with a roof cowl:

The minimum distance from the wall must be observed (see wall mounting as well).

Install the wall sleeve or duct.

Surface- or recessed-mounted connecting cable guide.

ECA 100 ipro and ECA piano only available as recessed-mounted fans.

Drain off any condensation present in the duct using a siphon. Fit a T-piece with siphon in the duct (odour seal) for this purpose.

Proper duct insulation reduces the build-up of condensation considerably.

Use a roof cowl with the condensation drain pointing outwards (see recommended accessories).

INSTALLATION INSTRUCTIONS

ECA 150 ipro KRCH

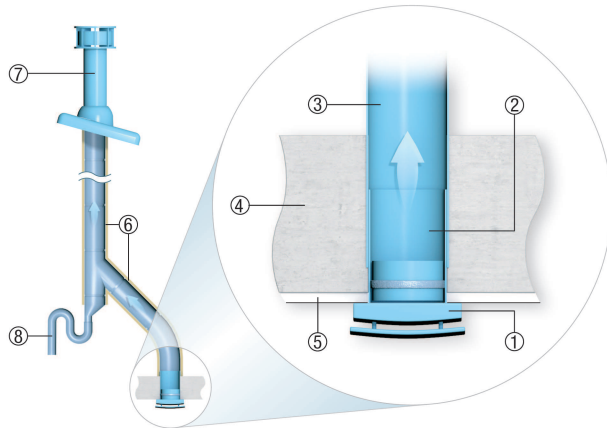

- ① ECA fan
- ② Sleeve
- ③ Duct DN 100, DN 125 or DN 150
- ④ Masonry
- ⑤ Plaster
- ⑥ Insulation
- ⑦ DF/DP roof cowl
- ⑧ Condensation drainage (siphon)