



MAICO

VENTILATOREN

Practical Guide for Comfort Ventilation

in new-build and renovated properties

for homes, offices and
commercial and industrial buildings

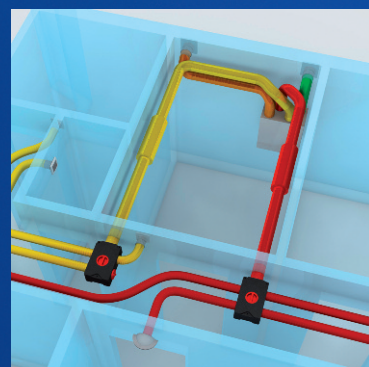

Healthy living and working

www.maico-fans.com



MAICO

VENTILATOREN

Practical Guide for Comfort Ventilation

in new-build and renovated properties

for homes, offices and
commercial and industrial buildings

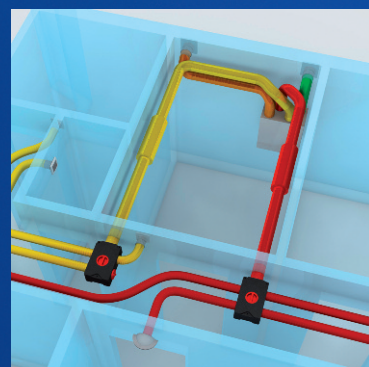

Healthy living and working

www.maico-fans.com

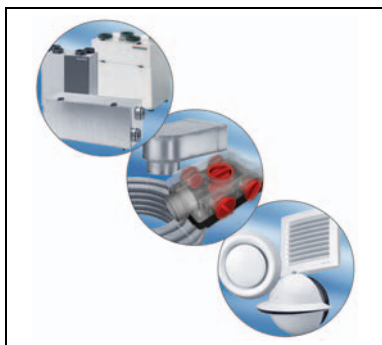

Planning Instructions

1. Introduction	2
2. Planning fundamentals	3
3. Practical planning	10
4. Configuration examples	25



Installation Instructions

5. Installation	28
6. Commissioning	34
7. Maintenance and cleaning	35



Products

8. Room air systems and accessories	38
---	----

Index	68
-------------	----

1. Introduction

The desire for a comfortable home is as old as humanity itself. Even our distant ancestors built hearths in their caves to keep warm and enjoy a degree of cosiness, though a smoky and draughty interior were the price they had to pay. As civilisation developed, demands in terms of climate within the home rose steadily. Thanks to the human commitment to progress, and to advances in technology, it is today possible to create a climate in the home which perfectly meets the individual needs and wishes of the residents. Room air systems from MAICO are designed to create and maintain ideal conditions in every room in the home.

Whether clients are looking for

- fresh, dust-free air,
- energy-efficient ventilation,
- odour elimination,
- pollen-free air,
- dehumidifying or
- heat.

MAICO room air systems can meet their wishes!

This practical guide is intended to assist

- planners during the planning phase as well as
- installers and other contractors with regard to installation, provision of advice and selling



MAICO ventilation systems are suitable for both renovation of existing buildings and new-build projects.

Systems can be designed

- for apartments,
- for detached, semi-detached or terraced houses,
- for apartment blocks, or
- for commercial properties.

Depending on your needs, you can choose between:

- a room air system without heat recovery, or
- a room air system with heat recovery, or
- a room air system with heat recovery and a brine earth heat exchanger.

The individual system components are designed by MAICO and optimised to work together.



2. Planning Fundamentals

2.1. Functioning of a comfort ventilation system with heat recovery

The core of a climate control system with heat recovery is the central heat recovery unit, incorporating fans, air filters, a heat exchanger and controls.

A duct system extracts warm air from rooms susceptible to odour and damp, such as the kitchen, bathroom and WC, and cools it by way of the heat exchanger. At the same time fresh, cold outside air is drawn in and likewise routed via the heat exchanger. Some 70 - 90 % of the heat in the exhaust air is discharged to the outside air, which can then in turn be routed through a duct system and via valve back into the living and utility areas as pre-heated supply air.

This principle (of so-called "cross-ventilation") is usually maintained in operation round the clock, and reduces ventilation heat loss by around 70 - 90%. It also eliminates the problems associated with odour, steam, pollutants or exterior noise penetrating through open windows or doors. Consequently, the home is turned into a veritable "climatic spa" environment.

Home climate control systems can be deployed to meet a broad range of requirements based on an extensive package of accessories. With regard to system control, especially, a wide range of parameters can be controlled: time, temperature, air exchange rate, etc.

MAICO has developed its home climate control systems specially for detached, semi-detached and terraced houses and apartment buildings.

The systems can be installed in new-build homes and in the course of renovation projects.

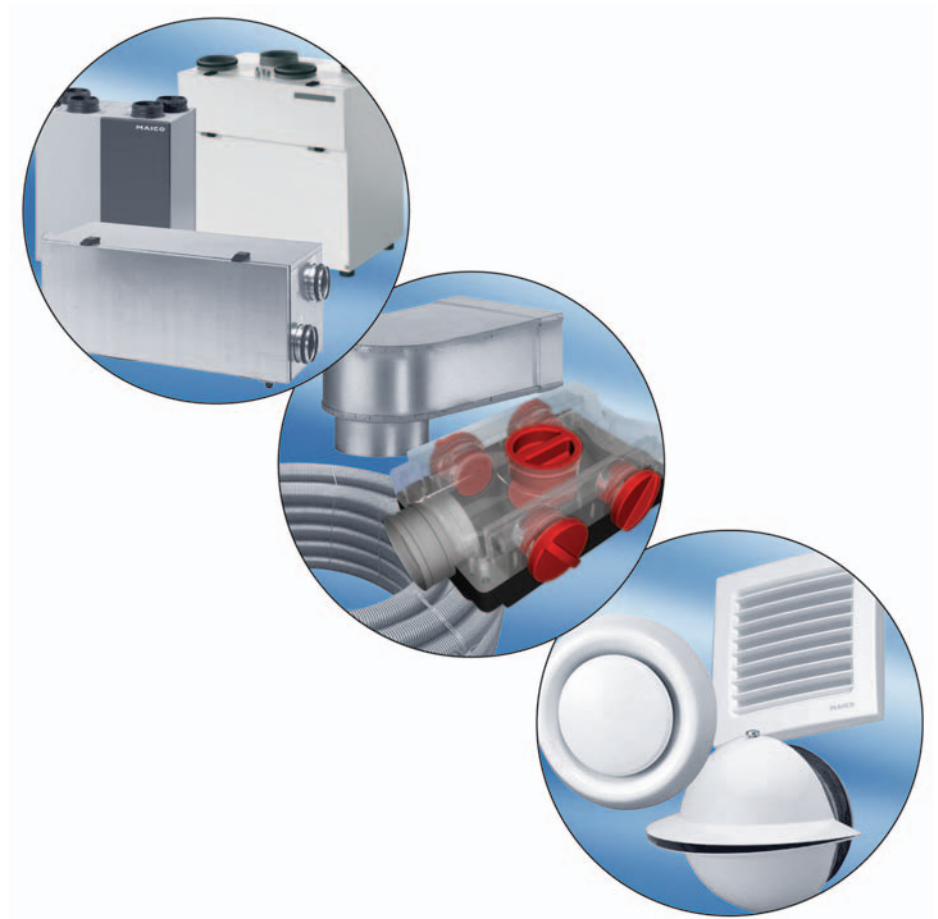

2.2. Glossary

Air exchange

The exchange of air in enclosed rooms.

The measure of the exchange is termed the **air exchange rate**.

Air exchange rate

Indicates how often the entire volume of room air is exchanged and replaced by fresh air in a given time.

The air exchange rate corresponds to the frequency of air exchange in one hour. An air exchange rate of 1 means that the air in the room is completely "renewed" once per hour.

Outside air

The air taken in from the outside.

Outside air rate

When calculating the personal air volume, the number of people continuously present in the room is taken into account. Guide value: 30 m³/h per person.

Supply air

The air flowing into the room.

Exhaust air

The air taken extracted from the room.

Outgoing air

The air discharged into the open.

Air volumetric flow

The volume of air transported in a given time [m³/h].

Air opening

Opening in the room (wall, ceiling or floor) through which air can flow in or out (e.g. grille, disk valve or blower nozzle).

Through-flow opening

Opening through which the air flows from one room to another depending on the direction of flow.

Heat recovery efficiency

Measure of the heat recovery from the exhaust air, including the energy recovered from any condensation. The heat from other sources incorporated into the supply air flow (such as the exhaust heat from a motor) is also included.

Damp-proofing ventilation ($q_{v,ges,FL}$)

User-independent ventilation aimed at avoiding damage from mould and damp in the building (in minimal operation) dependent on the level of thermal insulation offered by the building under normal usage conditions (damp loads, room temperatures).

Reduced ventilation ($q_{v,ges,RL}$)

User-independent ventilation which meets the minimum requirements in terms of room air quality under normal usage conditions (damp and pollutant loads).

Nominal ventilation ($q_{v,ges,NL}$)

Ventilation necessary to protect the structural integrity of the building and to meet hygiene and health requirements in regulation use of a usage unit (normal operation).

Intensive ventilation ($q_{v,ges,IL}$)

Temporarily necessary increased ventilation to reduce peak loads (full load operation).

Residential / usage unit

Residential unit, detached house or comparable other living space.

2.3. Standards and regulations

Conformance to the following standards must be ensured in planning:

DIN 1946-1	Heating, ventilation and air conditioning: terminology and graphical symbols
DIN 1946-6	Heating, ventilation and air conditioning - part 6: Domestic ventilation; general requirements for design, execution, labelling, commissioning, delivery and maintenance
DIN 1946-10	Domestic heating, ventilation and air conditioning
DIN 4102	Fire behaviour of building materials and elements
DIN 4108-7	Thermal insulation and energy economy of buildings - part 7: Airtightness of buildings, requirements, recommendations and examples for planning and performance
DIN 4109	Sound insulation in buildings; requirements and testing
DIN 18017-1	Ventilation of bathrooms and WCs without outside windows; single-shaft systems without ventilators
DIN 18017-3	Ventilation of bathrooms and WCs without outside windows, with ventilators
DIN V 24194	Duct components for heating, ventilation and air conditioning systems; leak-tightness; leak-tightness of air duct systems
DIN EN 779	Particulate air filter for general heating, ventilation and air conditioning applications
DIN EN 832	Thermal performance of buildings – Calculation of energy use for heating - Residential buildings
DIN EN 12831	Heating systems in buildings - method for calculation of the design heat load
DIN EN 13779	Ventilation of non-residential buildings
EN 60335-1	Safety of household and similar electrical appliances - part 1: General requirements
EN 60335-2-30	Safety of household and similar electrical appliances - part 2 - 30: Particular requirements for room heaters
VDI 2071	Heat recovery in heating, ventilation and air conditioning plants
VDI 2081	Noise generation and noise reduction in air conditioning systems
VDI 2087	Air ducts - Operating and construction fundamentals
VDI 3801	Operation of air conditioning systems
VDI 6022	Hygienic requirements for ventilation and air conditioning systems and devices
VDMA 24186 T1, T2	Performance programme for maintenance of air condition and other technical systems in buildings part 1: Air conditioning systems and equipment; part 2: Heating systems and equipment
DIN VDE 0100	Erection of power installations with rated voltages below 1000 V
VBG 20	Refrigeration systems

The relevant state building codes

EnEV	German Energy-Saving Regulation relating to energy-saving thermal insulation and energy-saving building systems
LüAR	German Directive relating to fire prevention requirements for ventilation systems.
Construction law Standards imposed by building supervisory agencies.	

2.4. System design

The installation of a ventilation system must be planned very carefully in order to maintain functional safety. If correctly implemented, no draughts or disturbing noise will occur.

Key points in designing ventilation systems are:

- Calculation of the duct cross-sections and air speeds
- application-specific air openings
- Air channel design to standard
- Correctly calculated air volumes
- Correct setting of the supply air and exhaust air valves



To enhance comfort, it is advisable to specify the ventilation system so that control level 1 delivers an air exchange rate of approximately 0.3 1/h.

2.5. General notes

Central units should only be used for enclosed usage units. Multi-residency buildings required one central unit per residential unit, or each residential unit must have the facility to individually control the flows of supply and exhaust air.

A pre-determined constant volume of outside air is filtered in the central unit and routed to the individual rooms.

The same volume of air is discharged from the kitchen, bathroom or WC for example. Ventilation grilles should be fitted in doors leading to through-flow areas.

Openings to the through-flow areas should be installed, such as by removing door leafs or fitting door ventilation grilles.



When planning, pay particular attention to rooms with air-ventilated fireplaces. These may only be provided with air intake and vent systems under certain conditions (**see section 3.8**).

In such cases it is essential to consult the local authority department responsible for chimney-sweeping during the planning phase.

- Follow the installation instructions accompanying the system.
- A gap of 1.5 cm must be left beneath the room doors. Alternatively, door ventilation grilles can be installed.
- Be sure to comply with the specifications laid down by manufacturers of boilers and gas appliances.
- Service access to the duct system is gained by removing the disk valves, disconnecting the ducts from the unit, or through cleaning openings.
- Ducts and accessory fittings must be protected against dirt contamination.
- When installing ceilings, attention must be paid to the structural statics and to matters of sound insulation and of fire protection where appropriate. This requires consultation with the architect and structural engineer.

Supply and exhaust air systems with heat recovery

In controlled residential ventilation incorporating supply and exhaust air systems and heat recovery, air is extracted from rooms susceptible to odour and damp such as the kitchen, bathroom and WC.

The outside air is filtered and then routed via ducts to the rooms not subject to odour or damp (so-called supply air rooms), such as living rooms, bedrooms, playrooms, offices, etc.

The outside air can be pre-heated in Winter by means of an earth heat exchanger so as to prevent freezing-up of the plate heat exchanger. This ensures constant running. This earth heat exchanger cools and dehumidifies the outside air on hot Summer days.

It can be combined with fire protection systems without further modification.

Exhaust air system

An exhaust air system provides you with a simple ventilation solution. The fresh air is supplied by means of outside air vents in the window or wall. The odorous or damp air in the kitchen, bathroom and WC is extracted.

The exhaust air can be discharged to the outside from each usage unit (detached house or apartment in a multi-residency building) by way of the ZEG and the EFR. In a multi-residency building with one central unit, all usage units are ventilated.

Exhaust air solutions do not include heat recovery.

2.6. Selecting a ventilation system

When selecting the most suitable ventilation system, a distinction is made between two basic ventilation methods.

Centralised supply / exhaust air

In centralised ventilation multiple residences and rooms on all floors of a building are connected to one communal main duct. Supply and exhaust air ducts run throughout the building.

The building's utility room houses the central ventilation unit which controls the air circulation throughout the building.

It can be combined with fire protection systems without further modification.

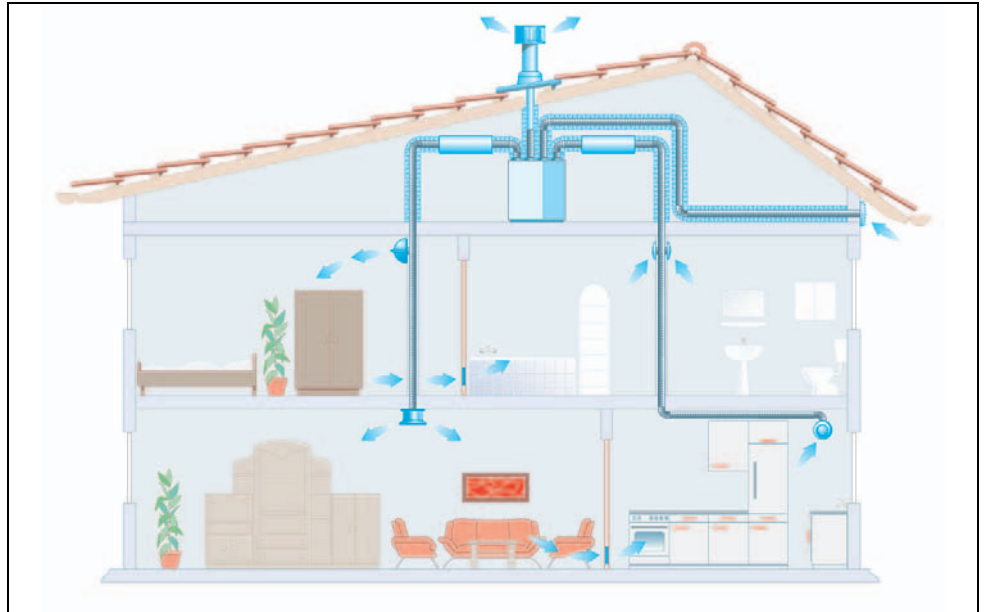

Centralised exhaust air

Centralised exhaust air units provide you with a simple ventilation solution. The fresh air is supplied by means of vents in the window or wall.

Centralised exhaust air can be implemented either by special appliances which are connected to a ducting system or by a roof fan which provides ventilation through a central shaft.



This system does not include heat recovery.

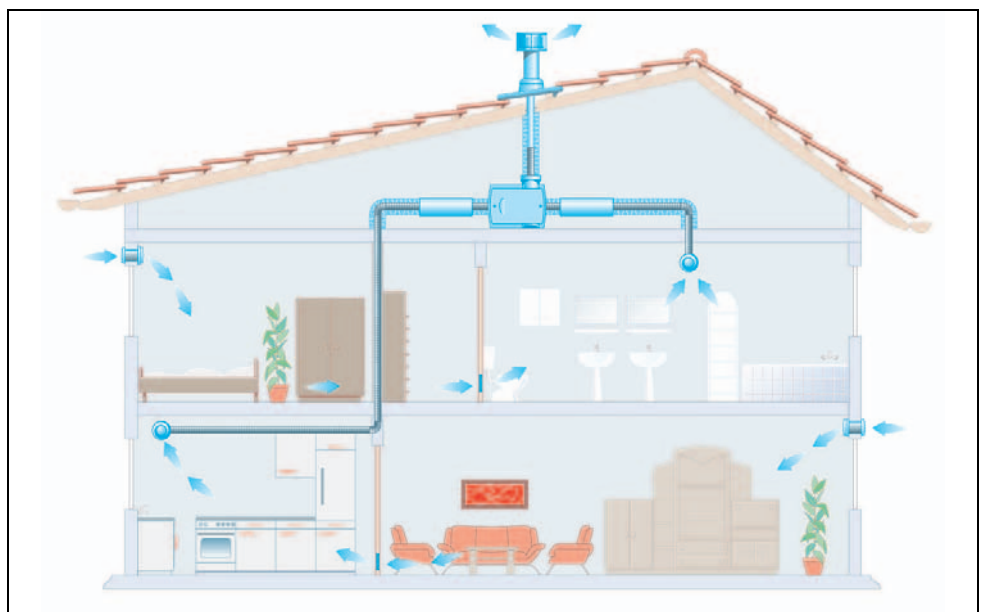

2.7. Appliance comparison table

	WRG 35	WS 150	WRG 180 EC	WS 250	WR 300	WR 400	WS 600	ZEG	ZEG EC
Centralised supply / exhaust air		✓	✓	✓	✓	✓	✓		
Centralised exhaust air								✓	✓
Decentralised supply / exhaust air	✓								
For homes up to approx. 120 m ² Living area	✓	✓	✓					✓	
For homes up to approx. 200 m ² Living area	✓			✓					✓
For homes up to approx. 250 m ² Living area	✓				✓				
For homes up to approx. 300 m ² Living area	✓					✓			
For homes up to approx. 400 m ² Living area	✓						✓		
Connection diameter 100 / 125 mm									
Connection diameter 125 mm		✓	✓					✓	✓
Connection diameter 160 mm				✓	✓	✓			
Connection diameter 225 mm							✓		
Flow rate 70 to 165 m ³ /h		✓							
Flow rate 50 to 180 m ³ /h			✓						
Flow rate 100 to 250 m ³ /h				✓					
Flow rate 100 to 300 m ³ /h					✓			✓	
Flow rate 100 to 400 m ³ /h						✓			
Flow rate 200 to 550 m ³ /h							✓		
Flow rate 17 to 60 m ³ /h	✓								
Flow rate 172 to 208 m ³ /h									
Flow rate 85 to 375 m ³ /h									✓
Heat recovery efficiency	> 70 %	90 %	90 %	92 %	90 %	90 %	90 %	-	-
Average power consumption by volume	0.15 Wh/m ³	0.19 Wh/m ³	0.31 Wh/m ³	0.35 Wh/m ³	0.33 Wh/m ³	0.36 Wh/m ³	0.41 Wh/m ³	-	0.119 Wh/m ³

The ventilation navigator provided on our website at www.maico-fans.com can help you in selecting the right room air system.

2.8. Planning a room air system

The planning of a room air system for new-build projects or for renovations is essentially the same.

Planning a new build

Preconditions for laying flexible steel ducts in concrete ceilings.

Laying flexible steel ducts in the concrete may influence the structural statics of the building. The potential effects must be checked by a structural engineer.

A minimum clearance corresponding to the diameter of the duct must be maintained between the ducts. The duct layout should be shown on the building plan, in order to avoid damage when drilling holes later. For casting in concrete we recommend using size 63 ducts, as they have the least depth. Size 75 ducts are suitable too, however.

Planning a renovation

Preconditions for laying flexible steel ducts in false ceilings

When installing false ceilings, attention must be paid to the mounting height of the air distributor MF-V and the position of the valve adapter MF-A.

The mounting height of the distributor is 150 mm. With regard to the position of the valve adapter, its distance from the ceiling is of particular importance. The flexible steel ducts must be fixed in place before and after bending.

2.9. Specific details for your application case

The advantages of a ventilation system are that they save energy, the climate in the individual rooms is made more pleasant, and harm to health by draughts or mould is prevented.

Ventilation system in an apartment – Renovation

Planning for an apartment should preferentially incorporate size 90 or 75 flexible steel duct, so as to avoid high pressure losses. The duct system is then installed inside a false ceiling. If it is necessary to place the outgoing air and outside air openings on the same wall, you must ensure that the distance between the two openings is as large as possible.



Ventilation system in a workshop, retail outlet, doctor's surgery, lawyer's office or the like

The basic planning procedures as set out in **section 3.1** are the same in these applications too. However, the detailed design of the ventilation system depends heavily on the specification. As commercial and industrial environments often involve higher volumetric flows, use of size 90 flexible steel ducts is advisable in such applications.

The supply and exhaust air volumetric flows in commercial and industrial environments are primarily determined dependent on heat loads, odour loads, and the like.

So the global figure of 30 m³/h per person is rarely applied.

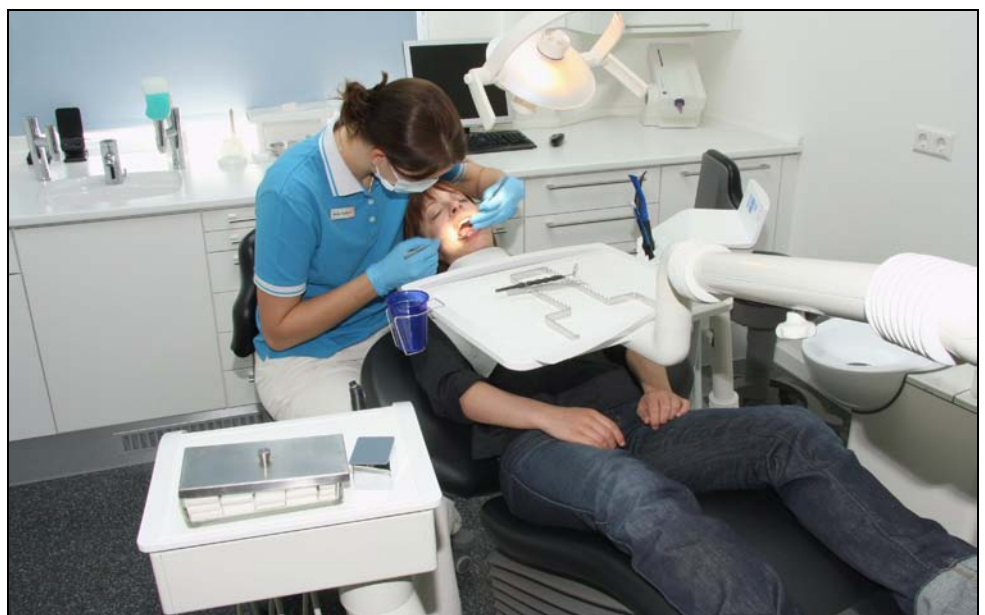

3. Practical planning

3.1. Planning procedure

1. Define the supply air, exhaust air and through-flow zones.
2. Determine the supply and exhaust air volumetric flows based on the relevant standards and directives.
3. Specify the positions, numbers and sizes of air valves and through-flow openings.
4. Specify the location of the ventilation unit and the ducting.
 - The supply and exhaust air ducts should be roughly the same size.
 - Allow for discharge of condensation.
5. Provide sound insulation by installing duct and telephony sound absorbers.
6. Specify the positions of the outgoing air and outside air openings, paying attention to thermal insulation.
7. Position the operating unit in the living area.

3.2. Room allocation

All rooms in the residential unit must be allocated to one of the three zones.
The table below presents examples of possible allocation:

Supply air zones (sleeping/living area)	Exhaust air zones (rooms subject to odour and damp)	Through-flow zones (transitional areas)
Living room	Kitchen	Landing
Dining room	Utility room	Porch
Bedroom	Bathroom	Hall
Playroom	WC	Stairwell
Study	Cupboard	
Hobby room	Laundry room	
Guest room		

3.3. Influence of the building shell on the ventilation system

Every building is subject to natural infiltration due to unavoidable leakage. This means that a certain amount of fresh air may penetrate into the building without any ventilation system in place. This effect is, however, heavily dependent on factors such as pressure difference, the height of the building and the wind direction.

The calculated infiltration can be deducted from the nominal ventilation. This does of course also affect the volumetric flows of the reduced and intensive ventilation levels. The infiltration factor may impact primarily on the design of the ventilation unit.

3.4. Calculation bases

When planning a fan-assisted ventilation system, the primary factors to consider are the room air quality and humidity.

The ventilation system should be designed so as to guarantee nominal ventilation (without user assistance) 24 hours a day. Planning of the ventilation system should be based not only on the number of people in the unit concerned, but should consider the overall situation. This must also include the leak-tightness of the building.

In the DIN standard 1946-6:2008 this is termed the "effective volumetric air flow due to infiltration $q_{v,Inf,wirk}$ " – see also section 3.3.

The total outside air volumetric flow ($q_{v,ges}$) is composed of

- the volumetric air flow based on ventilation systems ($q_{v,LtM}$),
- the effective volumetric air flow due to infiltration ($q_{v,Inf,wirk}$)
- and the effective volumetric air flow due to active window opening ($q_{v,FE,wirk}$).

Active window opening does **not** have to be taken into account when planning ventilation systems to DIN 1946-6:2008.

The total outside air volumetric flow with nominal ventilation ($q_{v,ges,NL}$) is determined by a comparative method.

The minimum total outside air volumetric flow by useful area (table 1) is compared against the total exhaust air volumetric flow by room type (table 2). The highest value is applied to the design and to further calculations. You will find the individual calculation formulas for the different volumetric flows in section 3.5.

The following tables are based on DIN 1946-6:2008:

	Area of usage unit A_{NE} (in m^2)									
	≤ 30	50	70	90	110	130	150	170	190	210
Ventilation for damp-proofing / thermal insulation high $Q_{v,ges,NE,FLH}$ (m^3/h)	15	25	30	35	40	45	50	55	60	65
Ventilation for damp-proofing / thermal insulation low $Q_{v,ges,NE,FLG}$ (m^3/h)	20	30	40	45	55	60	70	75	80	85
Reduced ventilation $Q_{v,ges,NE,RL}$ (m^3/h)	40	55	65	80	95	105	120	130	140	150
Nominal ventilation $Q_{v,ges,NE,NL}$ (m^3/h)	55	75	95	115	135	155	170	185	200	215
Intensive ventilation $Q_{v,ges,NE,IL}$ (m^3/h)	70	100	125	150	175	200	220	245	265	285

Table 1: Minimum total outside air volumetric flows for usage units including infiltration.

	Nominal ventilation NL	Total exhaust air volumetric flows $Q_{v,ges,R,ab}$ (in m^3)		
		Ventilation for damp-proofing FL	Reduced ventilation RL	Intensive ventilation IL
Study	25	$Q_{v,ges,FL}$ = $(Q_{v,ges,NL} / Q_{v,ges,NE,NL})$ •	$Q_{v,ges,RL}$ = $(Q_{v,ges,NL} / Q_{v,ges,NE,NL})$ •	$Q_{v,ges,IL}$ = $(Q_{v,ges,NL} / Q_{v,ges,NE,NL})$ •
Basement (hobby room) Corridor (optional) WC				
Kitchen / diner				
Bathroom with / without WC	45	$Q_{v,ges,NE,FL}$	$Q_{v,ges,NE,RL}$	$Q_{v,ges,NE,IL}$
Shower room	100			
Sauna / gym				

Table 2: Total exhaust air volumetric flows $Q_{v,ges,R,ab}$ with fan-assisted ventilation for individual rooms with or without windows. Including effective infiltration.

Design air exchange $n_{50,AusI}$ for new build and renovation in 1/h		
Category ¹⁾		
A	B	C
1.0 ²⁾	1.5 ^{3), 5), 6)}	2.0 ^{4), 5), 6)}

Table 3: Design air exchange default values at 50 Pa differential pressure $n_{50,AusI}$

- 1) The average building has a $n_{50,AusI}$ rating of 4.5 1/h.
- 2) Fan-assisted ventilation in single-storey and multi-storey usage units
- 3) Free ventilation in new-build single-storey and multi-storey usage units and renovated single-storey usage units (e.g. typically in multi-residency buildings)
- 4) Free ventilation in renovated multi-storey usage units (e.g. detached houses)
- 5) The renovation specifies at least one permanent air-tight building shell in line with recognised technical standards.
- 6) In the case of a partial renovation of the building shell, such as when replacing only some of the windows, it is advisable to specify the ventilation system according to the n_{50} rating for complete renovation of the building shells.

Ventilation system	Free ventilation		Supply / exhaust air system (balanced)	Fan-assisted ventilation		
	Cross-ventilation	Cross-ventilation and ventilation shaft		Exhaust air or supply air system		
Home type	All usage units			Single-storey usage units	Multi-storey usage units	
				with installation shaft	without	
ALD	0.5	0.6	-	0.65	0.7	0.8
ÜLD		0.15	0.45		0.15	
Shaft	-	0.35	-			
Fan	-	-	0.45	0.15		0.2

Table 4: Correction factor for the effective infiltrated air $f_{\text{wirK,Komp}}$

3.5. Calculation formulas

Formula collection

Circular area

$$A = r^2 \cdot \pi = \frac{d^2 \cdot \pi}{4}$$

Volumetric flow

$$\dot{V} = A \cdot v \cdot 3600 \text{ s/h}$$

Flow speed

$$v = \frac{\dot{V}}{A \cdot 3600 \text{ s/h}}$$

Air exchange

$$LW = \frac{\dot{V}}{V_R}$$

Dynamic pressure

$$p_{\text{dyn}} = \frac{\rho}{2} \cdot v^2$$

Single resistances

$$Z = \sum \zeta \cdot p_{\text{dyn}}$$

Duct friction

$$\Delta p_R = l \cdot R$$

Pressure loss

$$\Delta p_{\text{ges}} = l \cdot R + Z + \Delta p_{\text{Einbau}}$$

Continuity law

$$\dot{V}_1 = \dot{V}_2 \quad v_1 \cdot A_1 = v_2 \cdot A_2$$

Heat quantity

$$Q = m \cdot c \cdot \Delta \vartheta$$

Hydraulic diameter

- for any cross-sectional shape

$$d_h = \frac{4 \cdot A}{U}$$

for rectangle

$$d_h = \frac{2 \cdot a \cdot b}{a + b}$$

A	= Area in [m ²]
r	= Radius in [m]
d	= Diameter [m]
v	= Flow speed [m/s]
AE	= Air exchange
\dot{V}	= Volumetric flow [m ³ /h] (in duct / valve)
V _R	= Room volume [m ³]
p _{dyn}	= Dynamic pressure [Pa]
ρ	= Density of medium [kg/m ³]
Z	= Pressure loss due to single resistances [Pa]
ζ	= Resistance coefficient without unit
Δp _R	= Pressure loss due to duct friction [Pa]
l	= Duct length [m]
R	= Pressure loss [Pa/m]
Δp _{tot}	= Total pressure loss [Pa]
Δp _{fittings}	= Pressure loss due to fittings [Pa]
Q	= Heat quantity [Wh]
c	= Specific heat capacity [Wh/kg·K]
Δϑ	= Temperature difference [K]
D _h	= Hydraulic diameter

Total outside air volumetric flow

$$Q_{v,ges} = Q_{v,LtM} + Q_{v,Inf,wirk} + Q_{v,FE,wirk}$$

Outside air volumetric flow per usage unit, damp-proofing

Thermal insulation high (new build after 1995, complete renovation)

$$Q_{v,ges,NE,FL} = 0.3 \cdot q_{v,ges,NE,NL}$$

Thermal insulation low (unrenovated old building, built before 1995)

$$Q_{v,ges,NE,FL} = 0.4 \cdot q_{v,ges,NE,NL}$$

Outside air volumetric flow per usage unit, reduced ventilation

$$Q_{v,ges,NE,RL} = 0.7 \cdot q_{v,ges,NE,NL}$$

Outside air volumetric flow per usage unit, nominal ventilation

$$Q_{v,ges,NE,NL} = -0.001 \cdot A_{NE}^2 + 1.15 \cdot A_{NE} + 20$$

Outside air volumetric flow per usage unit, intensive ventilation

$$Q_{v,ges,NE,IL} = 1.3 \cdot q_{v,ges,NE,NL}$$

Volumetric flow due to infiltration

$$Q_{v,Inf,wirk} = f_{wirk,Komp} \cdot V_{NE} \cdot n_{50} \cdot ((dp \cdot f_{wirk,Lage}) / 50)^n$$

- $Q_{v,ges}$ = Effective total outside air volumetric flow
- $Q_{v,LtM}$ = Volumetric air flow based on ventilation (free or fan-assisted)
- $Q_{v,Inf,wirk}$ = Effective volumetric air flow due to infiltration
- $Q_{v,FE,wirk}$ = Effective volumetric air flow due to active window opening (not used for ventilation system design to DIN 1946.6:2008)
- $Q_{v,ges,FL}$ = Damp-proofing ventilation
- $Q_{v,ges,NE,FL}$ = Outside air volumetric flow per usage unit for damp-proofing ventilation
- $Q_{v,ges,RL}$ = Total outside air volumetric flow, reduced ventilation
- $Q_{v,ges,NE,RL}$ = Outside air volumetric flow per usage unit with reduced ventilation
- $Q_{v,ges,NL}$ = Total outside air volumetric flow, nominal ventilation
- $Q_{v,ges,NE,NL}$ = Outside air volumetric flow per usage unit for nominal ventilation
- $Q_{v,ges,IL}$ = Total outside air volumetric flow, intensive ventilation
- $Q_{v,ges,NE,IL}$ = Outside air volumetric flow per usage unit for intensive ventilation
- $Q_{v,Inf,wirk}$ = Effective volumetric air flow due to infiltration in m^3/h
- $f_{wirk,Komp}$ = Correction factor for the effective infiltrated air in the case of a ventilation component in m^3/h , value as per table
- $f_{wirk,Lage}$ = Correction factor for the effective infiltrated air dependent on the building position in m^3/h , default = 1
- V_{NE} = Air volume of the usage units in m^3
- n_{50} = Differential pressure in 1/h, default $n_{50,AuSI}$ from table or measured air exchange value at 50 Pa
- n = Pressure exponent (value 0.67 if no data available from air-tightness testing)
- dp = Design differential pressure in Pa (wind light = 2 Pa, wind strong = 4 Pa)

3.6. Safety requirements

Fire protection

If channels are installed in ceilings subject to fire protection requirements, minimum thicknesses of the ceilings and above and below the installed fittings must be allowed for. The precise installation scenario must be clarified with the site management based on the fire protection plan for the specific building.

See also DIN 4102-4 3.4, tables 9 and 10.

Your local authority department responsible for chimney-sweeping will be able to advise you of relevant fire safety regulations.

Smoke protection

Your local authority department responsible for chimney-sweeping will be able to advise you of relevant smoke safety regulations.

Sound insulation

A distinction is made between two basic methods of sound insulation:

- **Telephony sound**
- **Appliance sound**
- **Flow noise**



Footfall sound absorption must be taken into account when laying ducting under floors.

3.7. Sound transmission

Telephony sound

Sound transmission from room to room by way of the duct system is termed telephony sound.

- If the flexible steel ducts are laid in a star configuration and the minimum length requirement of 3 metres per flexible steel duct is observed, no telephony sound absorber is needed.
- To meet increased comfort demands, however, sound absorbers (such as the channel sound absorber) with connection size 80 / 150 or 80 / 200 can also be used.
- Where folded spiral-seams ducts are installed, telephony sound must be prevented by specifying telephony sound absorbers in the design.



The facility to clean the ducts using the cleaning set can then no longer be guaranteed however.

Appliance sound

Sound transmission from the unit itself by way of the duct system into the rooms is termed appliance sound. To avoid spreading this appliance sound around the home, sound absorbers should be installed between the Central unit and the distributors (as close as possible to the unit). They should be installed in the supply and exhaust air ducts.

Likewise if disturbing noise occurs at the outside air or outgoing air opening, the installation of sound absorbers is recommended. Attention must also be paid to sound insulation when installing the central unit!

Flow noise

Flow noise mainly occurs only when a certain flow speed has been reached. The higher the speed, the louder the noise. Consequently, it should be ensured that flow speeds are kept below 2.5 m/s. Sufficient numbers of valves should also be specified so as to minimise flow noise from the valve.

3.8. Component positioning



Outgoing air and outside air openings

The openings for outgoing air and outside air may be installed on the roof or on the wall. An adequate cross-section, in accordance with the rated volumetric flows, must be ensured.

The two openings must be installed at least 2 - 3 metres apart, so as to avoid "shorting" between the outgoing air and outside air.

When planning, please ensure that the outgoing air and outside air connections do not pose a noise nuisance to neighbours.

Positioning of the outgoing air and outside air openings

- Position the outside air grille on the shady side of the building wherever possible, so as to provide cool air.
- Do not install the outside air intake at locations subject to air pollution, such as near a garage, compost heap, etc.
- Install the outside air opening as high up as possible, so as not to draw in odorous air.
- Do not position outgoing air openings opposite neighbours' windows.



Example of positioning of outgoing air and outside air openings

Location of the central unit

The location of the central unit must meet the following conditions:

- Inside the building (e.g. in basement, kitchen cupboard, attic, etc.). Follow the installation instructions.
- Close to the outside air grille or the brine earth heat exchanger.
- Close to the outgoing air grille.
- Connection to the drainage system (to drain off condensation).
- Ensure accessibility for servicing and repair.
- If the unit is installed in a damp room, the room should be provided with additional ventilation, so as to protect the unit against corrosion.
- Install the unit in a frost-free environment.



Example of central unit installation: Basement or store cupboard

Laying the flexible steel duct

When laying the ducting the following conditions must be met:

- Short, symmetrical layout.
- Lay ducts straight-ahead wherever possible.
- The duct diameter depends on the property.
- Ducts installed between the roof beams and in the jamb walls should be beneath the insulation (in the warm zone) and so insulated against cooling and condensation.
- When installed in concrete ceilings, the ducts must be secured against uplift.
- Tight bend radiuses should be avoided, so as to minimum pressure loss.
- To avoid major pressure differences between the supply and exhaust air, it should be ensured wherever possible that the ducts are of equal length.
- The flow speed in the duct system should be a maximum of 2.5 m/s.
- Keep service openings accessible.

Dimensioning of the ducting

The flexible steel ducts should be dimensioned as follows, depending on specific application

Type	Nominal size DN	Application
MF-F63	63	New build
MF-F75	75	New build / renovation
MF-F90	90	Renovation



New build
Installation in concrete ceiling



Renovation
Installation in false ceiling*

* Position clamps at approx. 0.75 m intervals.



The structural engineer must always be consulted when installing ducting in a concrete ceiling.

Installation of folded spiral-seams ducts

- The duct diameter depends on the maximum volumetric flow and flow speed.
- Smooth-walled folded spiral-seams ducts should be used for the duct system. Ducts with a rough inner surface should be avoided for hygiene and flow-optimisation reasons.
- The folded spiral-seams ducts are secured by clamps to the ceilings and walls.
- For warm air-carrying ducts in cold environments (attics, basements, garages, etc.) an insulation thickness of approximately 100 mm is stipulated.
- Where masonry walls are broken through, the resultant gap should be closed off by suitable material.
- Air ducts which transport cold air into warm rooms should be provided with heat insulation (minimum 20 mm), made of closed-cell insulating material or with an external vapour barrier (including in the outer wall break-through), so as to prevent condensation.



Installation of folded spiral-seams ducts

Dimensioning of the folded spiral-seams ducts

The necessary duct diameters can be specified dependent on the calculated volumetric flows:

Duct diameter [mm]	Maximum volumetric flow [m ³ /h]	Maximum flow speed [m/s]
100	80	2.8
125	130	2.9
160	220	3.0



Positioning of the distributors

The locations of the distributors must meet the following conditions:

- Duct layout as uniform as possible in order to avoid major pressure loss differences.
- Sound absorbers should be installed between the distributors and the central unit, to prevent the fan noise from being transmitted into the ducting.
- Observe the minimum bend radii stipulated in the product section (section 8).
If the bend radii are inadequate the pressure losses will increase.
- On new-build projects the distance between the outer flexible steel ducts must be approximately 1.5 metres (with a size 63 duct).
- On renovation projects the false ceiling must be suspended down by approximately 180 mm.
- To attain the minimum bend radius, it is advisable to use the adjustable mounting brackets MF-FB 63 and MF-FB 75.

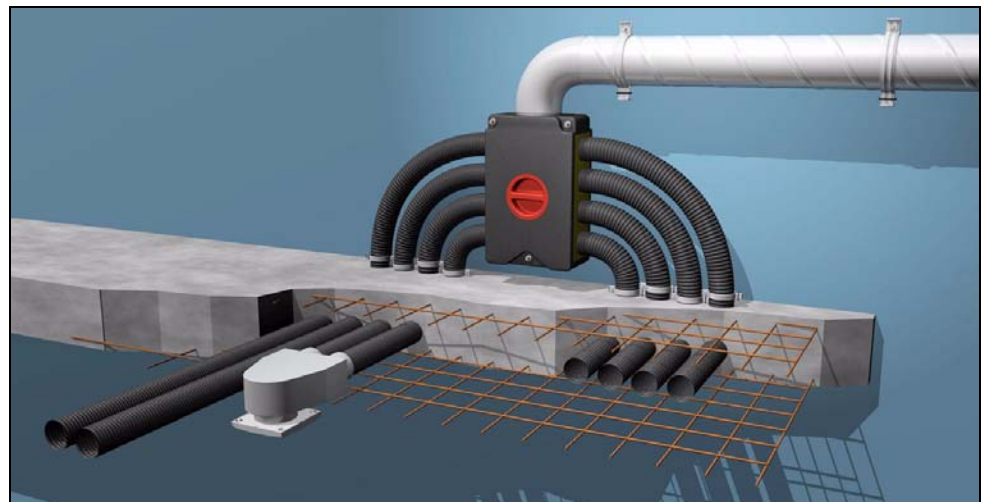

Installation in new build

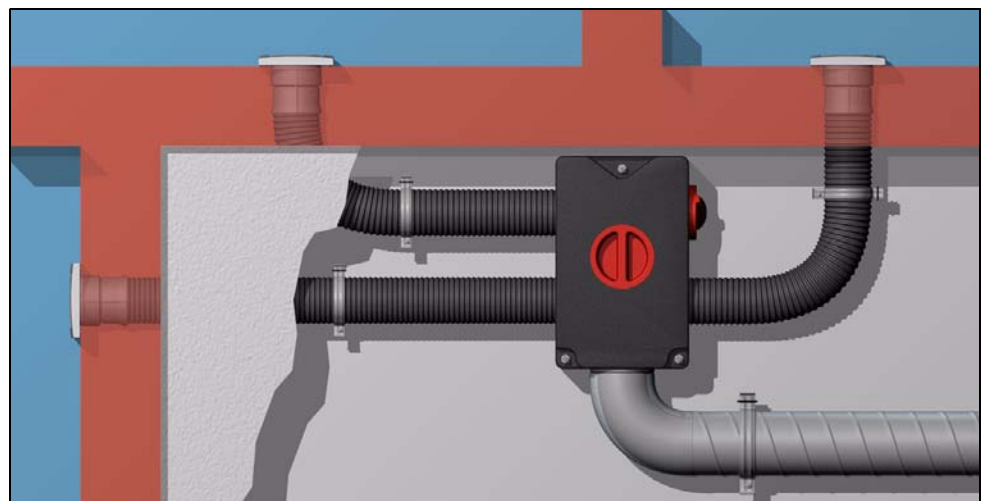

Installation in false ceiling (view from above)

Positioning of the supply / exhaust air openings

The supply and exhaust air openings must meet the following conditions:

- Maintain minimum clearance from walls and ceilings.
- Follow the recommendations given in the graphic.
- To avoid dirtying of the ventilation ducts, the exhaust air from the kitchen, WC, store cupboard etc. should be filtered.
- Where exhaust air valves are installed over doors, an "air short" occurs when the door is opened.
- You are advised to position the exhaust air valve as far as possible into the room.



Green: Correct positioning of the supply / exhaust air openings / Red: Incorrect positioning of the supply / exhaust air openings



Coanda effect

When these factors have been taken into account, the individual components can be entered in the building plan and the length of the ducts calculated. If supply air openings are installed correctly in the wall, the so-called **Coanda effect** occurs.

It is defined as follows:

A vacuum is created between the jet of supply air and the room ceiling. This carries the entrained supply air far into the room. This effect increases the throw. The effect can be used to transport the air as far as possible into the room.



When using blower nozzles, the distance from the nozzle to the ceiling should be approximately 0.2 m.

The supply air valves should not be positioned directly in the corner of the room, so as to ensure good air dispersal.

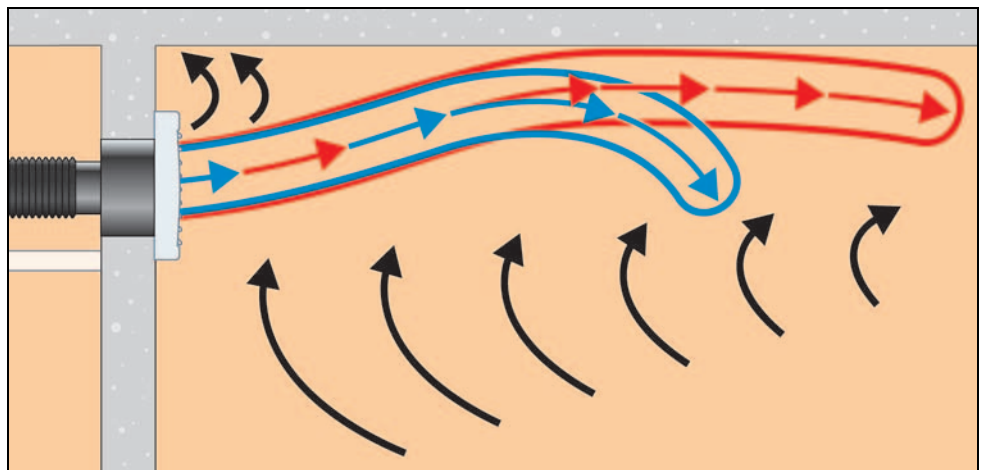

Coanda effect

3.9. Planning with brine earth heat exchanger

Theoretical principles

For the planning and design of a ventilation system with a brine earth heat exchanger utilising close-to-the-surface geothermal energy the following factors are decisive in terms of the efficiency of heat extraction from the earth:

- the specific heat capacity of the earth,
- its thermal conductivity,
- its density,
- its water / vapour diffusion, and
- the above and below ground conditions.

Underground factors to be considered are:

- installations,
- cables,
- drains, etc.

Overground factors to be considered are:

- property borders,
- buildings,
- drive-on access, and
- vegetation.



The geology is key to the installation process. It dictates the depth of installation, the installed pitch and the possible specific geothermal output of the collector.

As soil temperatures at a depth of 1 metre can reach freezing point even without heat extraction, and at a depth of 2 metres the heat dissipated from the surface decreases, the installation depth should be between 1.2 and 1.5 metres. At such a depth temperatures through the year range between 7 °C and 13 °C.

This temperature level can be used very effectively for heating purposes in Winter and for cooling in Summer.

Execution, installation and commissioning

The installation and commissioning of the geothermal collectors should be executed in accordance with the VDI 4640 standard, and installation of the associated safety fittings to DIN 4708: "Centralised hot water heating systems".

The collectors can be installed on the basis of a customised layout plan or – more cost-effectively – while constructing the foundations. In doing so, two circuits, with a maximum length of 50 metres (to limit pressure loss), are installed around the foundation.

As a rough guide, a requirement of 0.5 metres of brine pipeline per 1 m³/h air flow can be assumed, though a minimum of 100 metres for smaller installations.

To exclude the possibility of damage to the piping, the collector pipes should be laid in a 0.4 metre sand bed. Other advantages of this installation method:

- No air inclusions to reduce conductivity.
- Increased moisture absorption by the ground is guaranteed.

When installing, ensure that:

- the circuits are configured in parallel;
- the necessary pitch is maintained;
- the circuits are of equal length (to ensure uniform flow through the circuits and eliminate the need for costly and complex regulation on the distributor).

An appropriate vent must be installed at the highest point of the system. The distributor and the safety fittings must be installed at a suitable location. The change in volume of the heat transfer medium must be compensated by suitable measures. The system is run at a maximum operating pressure of 1.5 bar. The resultant change in volume of the heat transfer medium (approximately 0.8 to 1 % of the system volume) must be compensated by a membrane expansion vessel to DIN 4708. To protect against over-filling, a component-tested safety valve must be installed. A manometer with min and max pressure markings is required to monitor the pressure.

The system may only be charged with the glycol mixture. For the mixture ratio a 25 % glycol / water solution, corresponding to a value down to - 15 °C, is recommended. The collector circuits must be flushed through until total clear of air. Prior to commissioning, the complete system must be subjected to a pressure test at 1.5 times the pressure. The functioning of all components must be checked and the relevant test certificates issued to the operators.

Installation instructions:

- Geothermal energy collectors must not be built over.
- The surface above the collectors must not be sealed.
- PE high-pressure pipes must be protected against stone load, and so must be sanded-in.
- Sand bet in total minimum 0.4 m.
- Permissible bend radiuses depend heavily on the installation temperature.
- PE-HP 32 x 2.9 20 °C 0.7 m / 10 °C 1.2 m / 0 °C 1.7 m
- R1 / V1 = 50 m
- R2 / V2 = 50 m
- The air heat exchanger must be insulated against diffusion.

The number of circuits and the total pipe length depends on the output and the volumetric flow.

Required approvals (VDI 4640 sheet 1)

- According to section 3, subsection 3 clause 2, subclause b of the German Mining Act ("BergG"), geothermal energy is not a property of the land owner, but belongs to the federal administration.
- Planning, construction and operation of energy recovery systems utilising geothermal energy must comply with water management legislation and be in keeping with regional planning objectives.
- The provisions of the German Water Resources Management Act (WHG) apply, in conjunction with the water management legislation of the individual federal states and associated administrative regulations.
- DIN 4708 Centralised hot water heating systems

Hydraulic connection diagram, brine earth heat exchanger EW

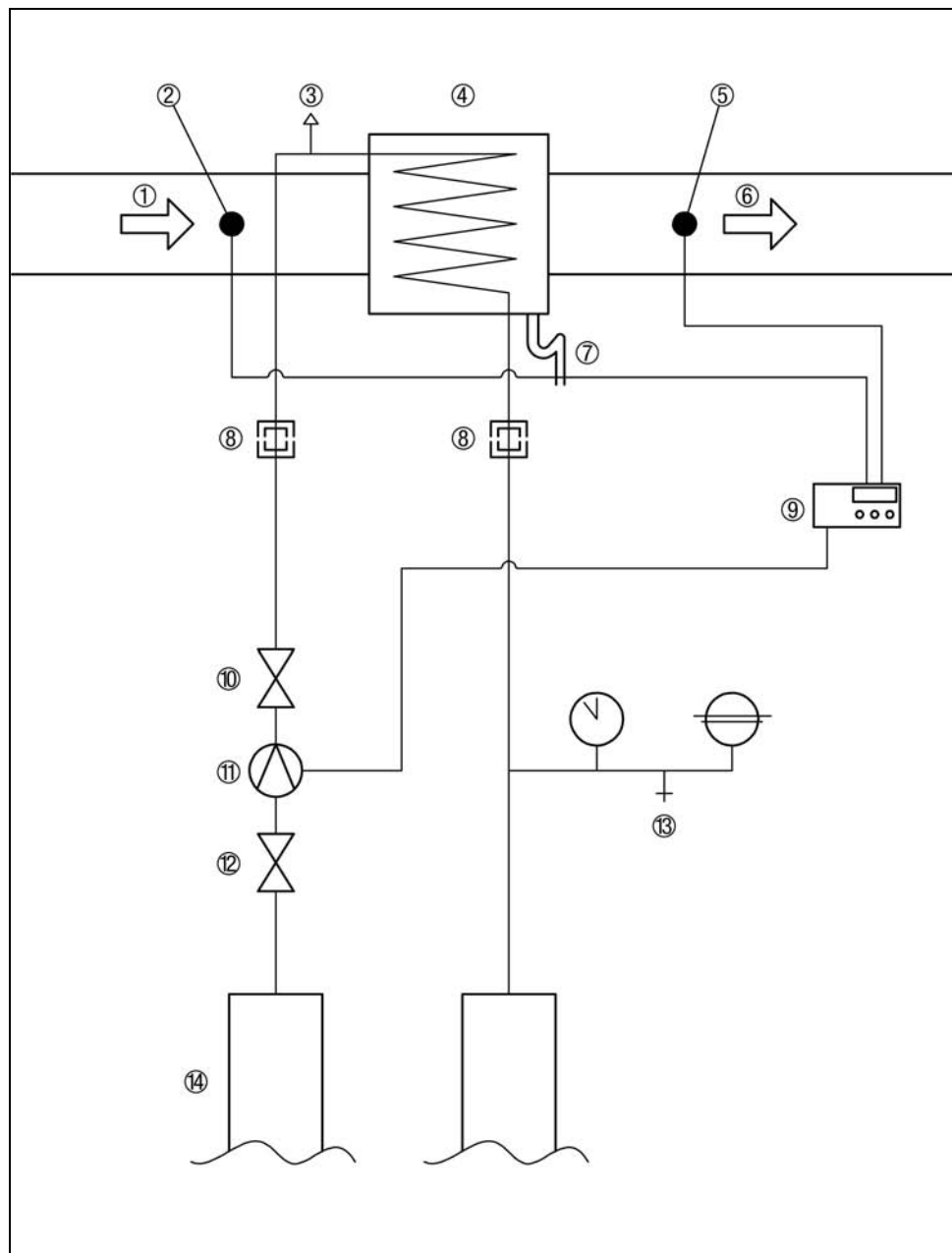

- ① Outside air
- ② Outside air temperature sensor
- ③ Ventilation
- ④ Brine / air heat exchanger
- ⑤ Temperature-controlled outside air temperature sensor
- ⑥ Temperature-controlled outside air to room air system
- ⑦ Condensation drain with siphon
- ⑧ Screw fittings
- ⑨ Control, 230 VAC
- ⑩ Shut-off
- ⑪ Grundfos UPS 25 – 40
- ⑫ Shut-off
- ⑬ Safety fitting
- Manometer
- KFE cock
- Membrane expansion vessel
- ⑭ Collector array

Layout plan

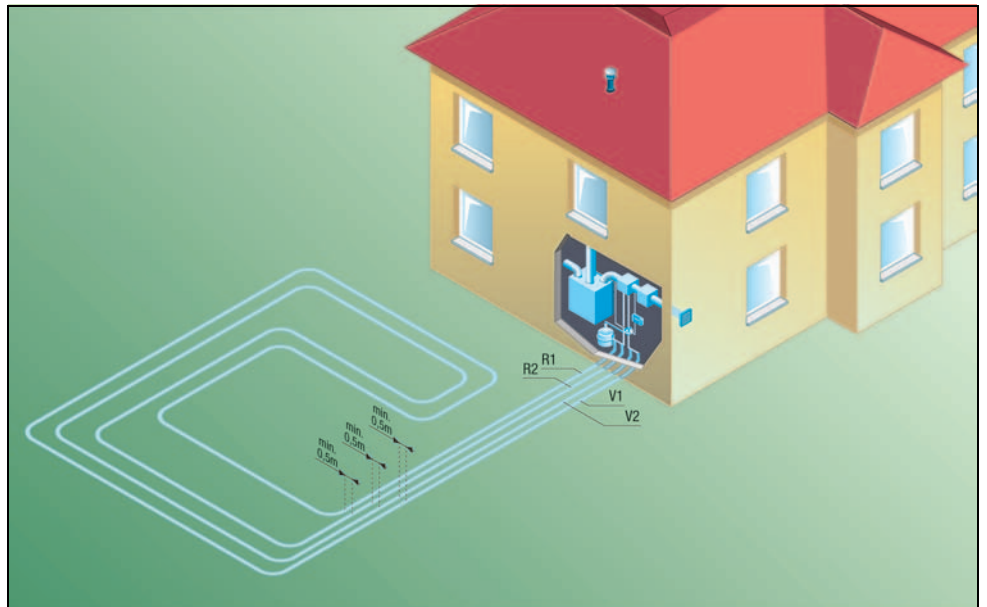

Collector layout plan

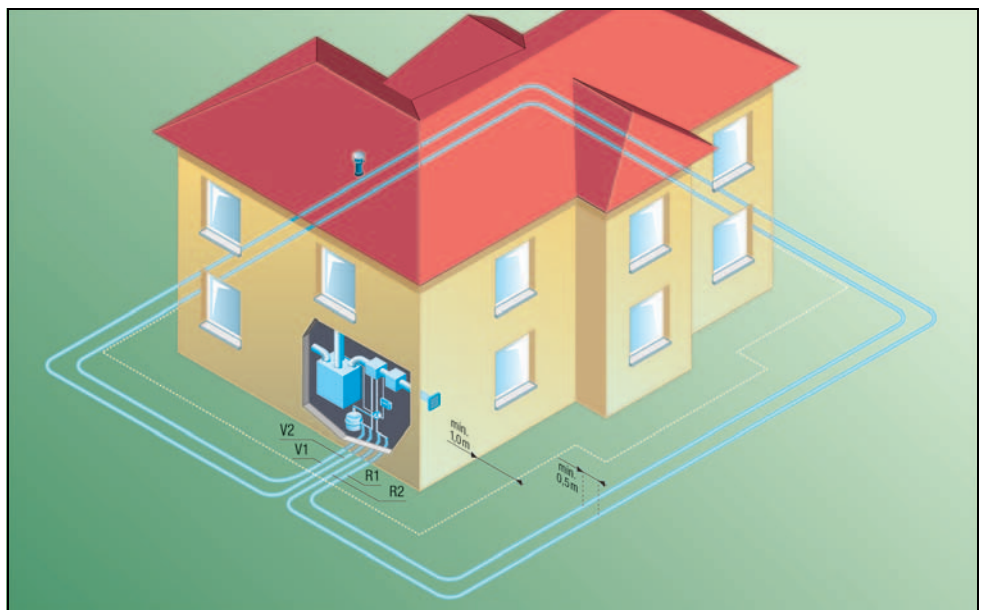

Custom layout plan

3.10. Combined operation of a ventilation system with a fireplace and / or extractor hood

If the room has a fireplace and / or an extractor hood, various criteria must be met. Any combination of fireplace, ventilation system and / or extractor hood must be clarified in advance in consultation with the local authority department responsible for chimney-sweeping.

Non-air-ventilated fireplace

In the case of a non-air-ventilated fireplace with DIBt approval (see relevant DIBt approval for fireplace. Some fireplaces are approved up to 8 Pa, others up to 10 Pa in-room negative pressure!) there are no restrictions on simultaneous operation of ventilation units, provided an in-room negative pressure of 8 Pa or 10 Pa as appropriate is not exceeded.

Air-ventilated fireplace

In the case of a air-ventilated fireplace, there are restrictions on simultaneous operation of ventilation units in living areas. If a negative pressure of more than 8 Pa or 10 Pa respectively occurs in the room in which the fireplace is installed, die fireplace is classed as air-ventilated (restricted approval). A safety device in accordance with E DIN 18841: 2005-12 is then required for the fireplace in question.



Basic rule:

- The in-room negative pressure when operating the ventilation system with an air-ventilated fireplace- must not be above 4 Pa!
- The air-ventilated fireplace must be monitored by a tested safety device with DIBt approval in accordance with the product standard E DIN 18841:2005-12!
- The ventilation system must be connected to the said tested safety device and be shut down if the safety device is tripped.
- The outside air volumetric flows necessary for operation of the air-ventilated fireplace must be provided separately from the outside air volumetric flows necessary for ventilation [E DIN 18841:2005-12].
- Ventilation systems with an F-marking are recommended [see E DIN 18841:2005-12].
- Fireplaces, like stoves, should be operated as **not** air-ventilated (approval!!!). The combustible air must be fed in from outside! A differential pressure controller should be installed as necessary.
- Boilers and thermal baths should likewise be operated as **not** air-ventilated.
- Where extractor hoods have an opening to the outside, an air-tight backflow preventer must be installed in order to prevent cold air being drawn into the kitchen when the extractor is not running. Air circulation hoods are more energy-efficient.

Air-ventilated fireplace and safety device* with DIBt approval / Product standard	Non-air-ventilated fireplace with DIBt approval / Product standard
- Ensure adequate combustible air supply! - External combustible air supply recommended	- Pay attention to fireplace approval - External combustible air supply required
Measures for a living area ventilation system to DIN1946-6, standard	
- Connect to safety device Ventilation system with F-marking recommended	- None
Measures for an extractor hood	
Recirculated air: None Exhaust air: Ensure adequate fresh air supply! Connect to safety device (e.g. vacuum monitor) or separate safety device (e.g. window contact switch)	Recirculated air: None Exhaust air: Ensure adequate fresh air supply! Separate safety device may be required (e.g. window contact switch, vacuum monitor)

* **Explanatory notes on the safety device**

The electrical and functional safety of the safety device is tested on the basis of the protection objectives in DVGW VP 121. A product standard on that basis has been published as E DIN 18814:2005-12.

Combined operation

During combined operation, a tested safety device must ensure that no hazardous negative pressure can occur. In the event of a malfunction the safety device shuts down an air-extraction system or a ventilation system or fireplace featuring quick control on the hot gas side.

Alternating operation

A tested safety device (e.g. based on negative pressure or temperature measurement) must ensure that the ventilation system and the fireplace are not operated simultaneously. The signal processing must be in keeping with this safety philosophy. Cutting the power supply is permissible and adequate.

4. Configuration examples

4.1. Configuration example Detached house

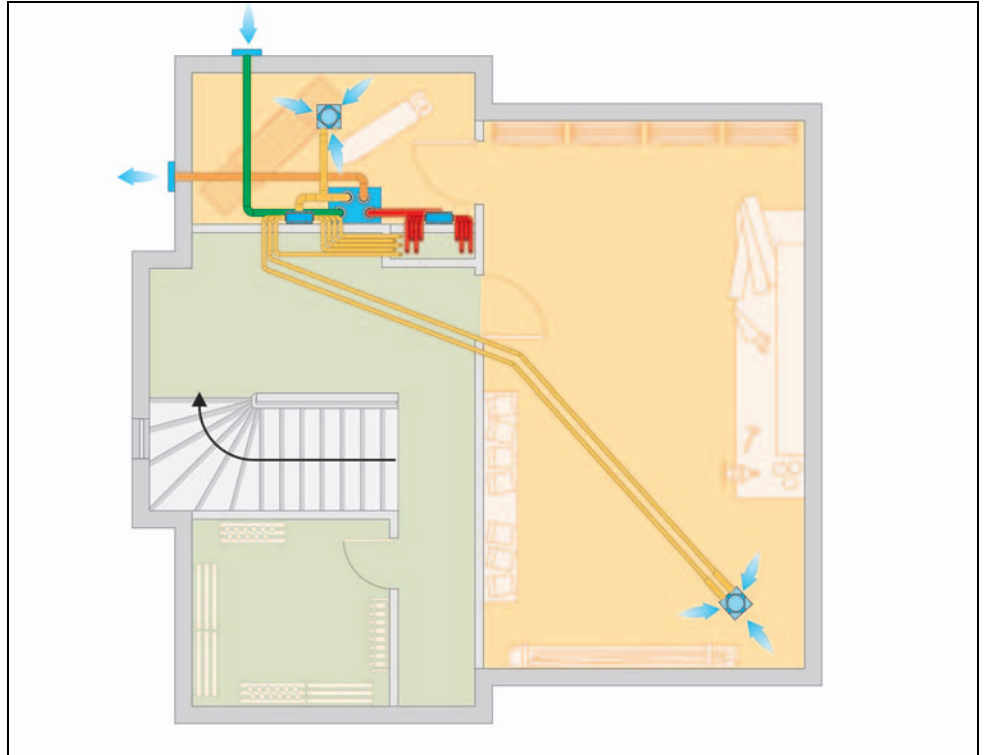

Basement

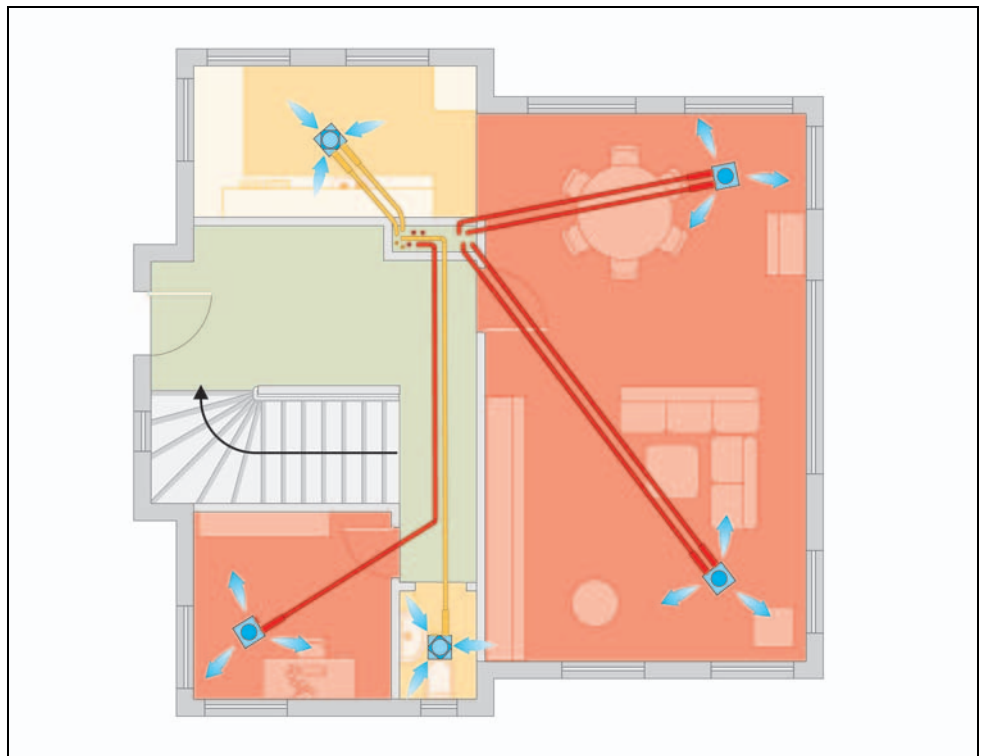

Ground floor

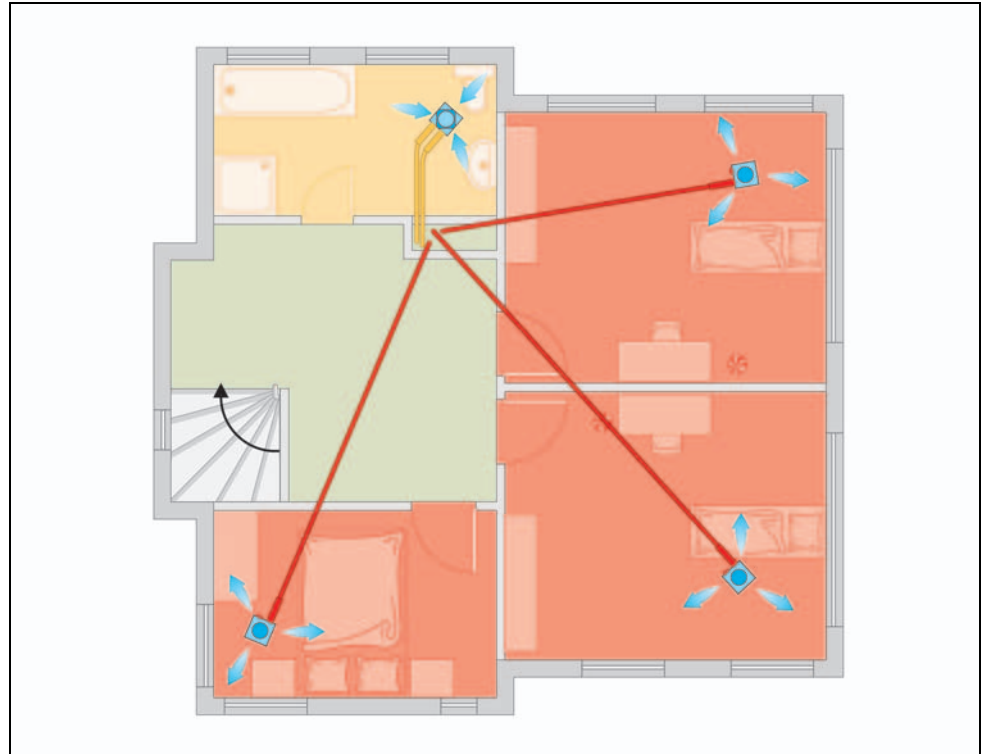

Attic

4.2. Configuration example Apartment

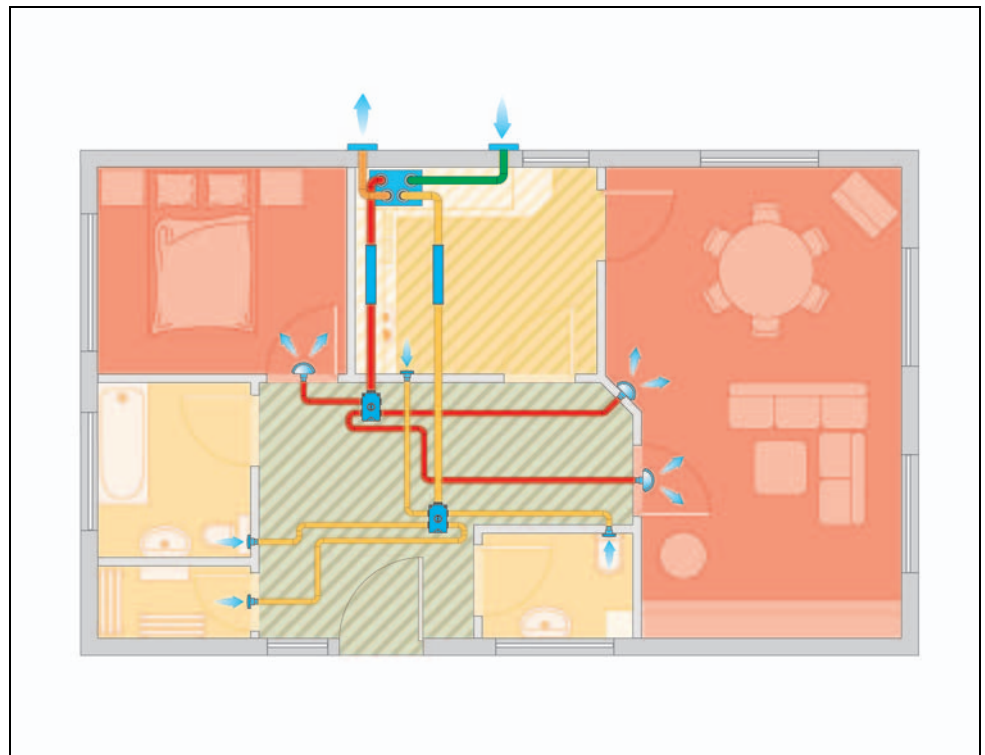

Apartment

4.3. Configuration example
Bungalow

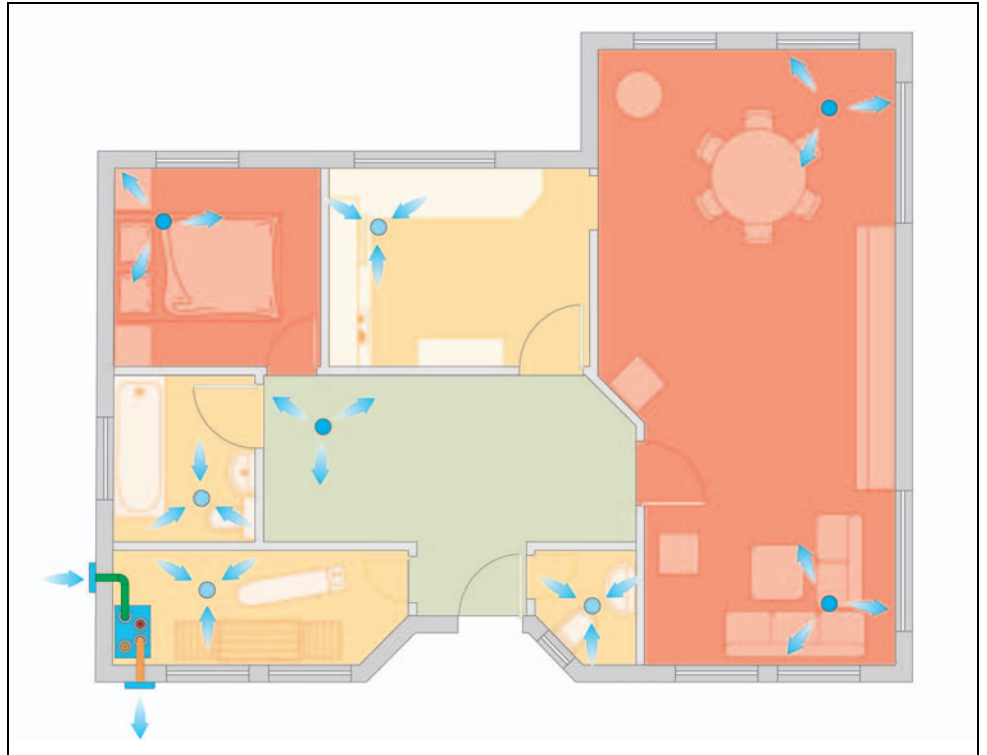

Ground floor

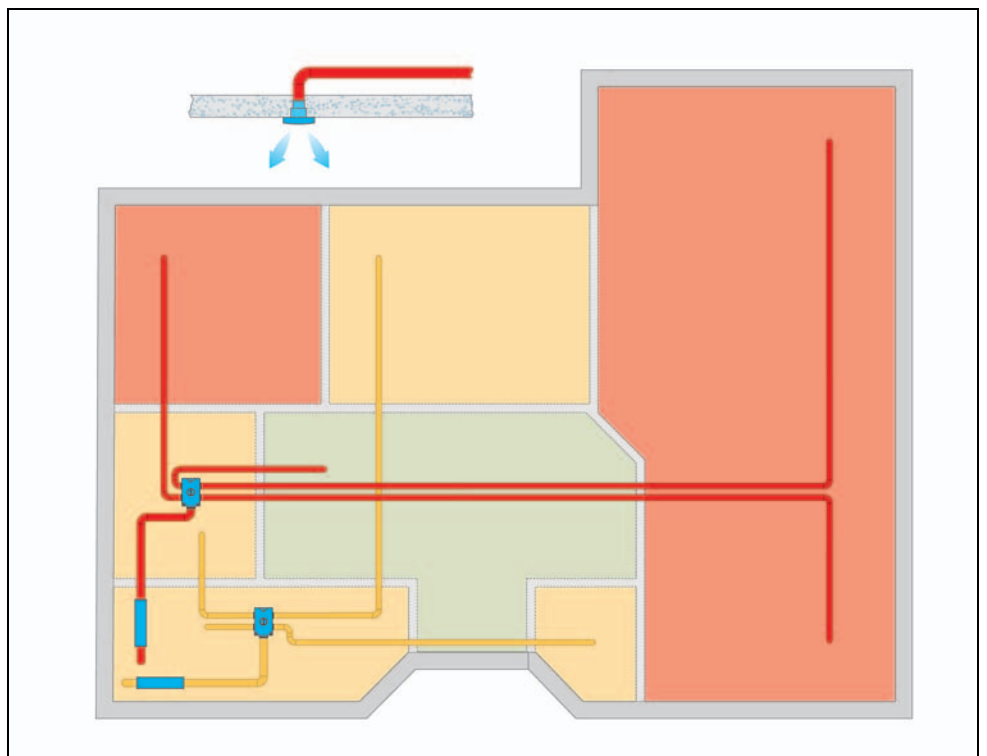

Attic extension

5. Installation

5.1. General notes

- The MAICO*Flex*-duct is a flexible steel duct system laid in a star configuration emanating from the distributor MF-V.
- Unused air distributor openings should be closed off by caps.
- Adhere to the planner's instructions when installing, and consult him or her in case of any problems.
- Refer to the accompanying installation instructions for the individual components.
- Make sure the ducts are correctly connected.
- Seal brackets routed through the ceiling with construction foam.
- Be sure to use suitable insulating, sound-absorbing and installation materials, such as matching duct sound absorbers, supply air and exhaust air valves, through-flow opening, etc.
- Install service openings in your duct system.
- If the unit is installed inside the heat-insulated building shell, insulate the outside air and outgoing air ducts in order to conserve energy and to avoid condensation (diffusion-tight). If installing outside the heat-insulated building shell, insulate supply and exhaust air ducts in the cold zone.
- Additionally insulate fixing cuffs with appropriate insulation material. This will prevent condensation.
- Sound insulation: Isolate wall and ceiling break-throughs with insulating strips.
- Adhere to the planning documentation drawn up by the consulting engineers.
- Be sure not to damage any existing ducting when fixing clamps in the ceiling.
- Check the duct system for damage before casting it in concrete.

5.2. Installation procedure for new-build projects

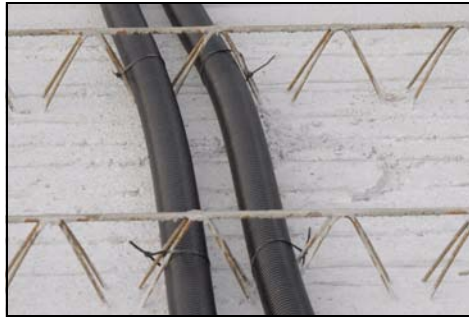

Step 1:

- Lay the flexible steel ducts on the precast ceiling and fix them by cable clips to the iron struts. The lattice girders must not be damaged in the process!
- When casting the ducts in concrete, make sure the ducts on the precast ceiling are firmly secured to the iron struts in order to prevent up-lift.

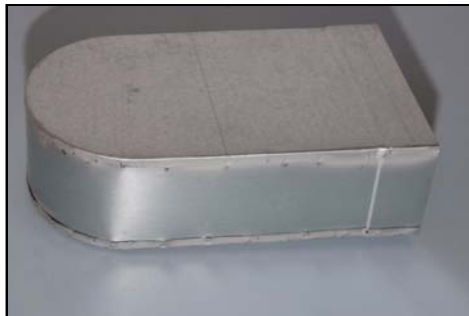

Step 2:

- Drill the core holes for the brackets, fix the plug-in adapters (3) into the brackets (4) and mount them on the precast ceiling. If necessary, seal the bracket in the core hole with PU foam.
- Connect the flexible steel ducts (1) to the plug-in adapters (3). It is advisable to use a sealing ring (2) in order to produce a water-tight joint. A suitable lubricant (5) can be used to aid mounting.
- Attach the plug-in adapter (3) to the bracket (4) by adhesive tape (6).
- Close off unused openings with a cap (included with the plug-in adapter).
- Label the flexible steel ducts so as to avoid mixing them up.

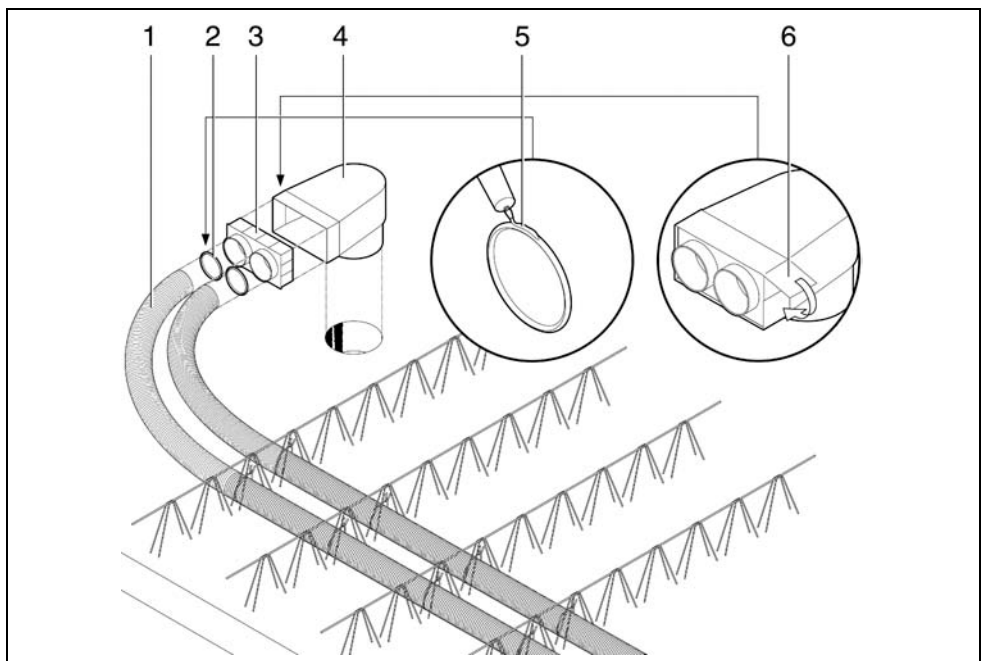
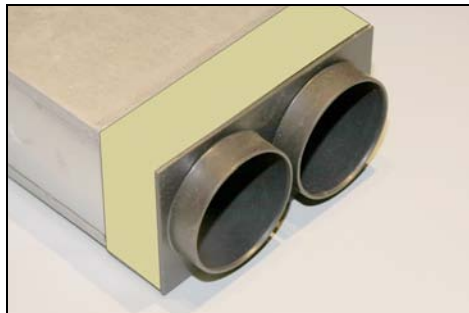

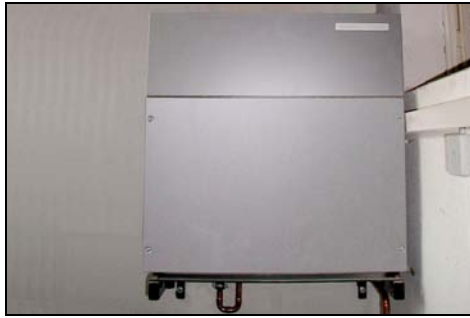

Step 3:

- Mount the central unit at its intended location.
- Fit the siphon.

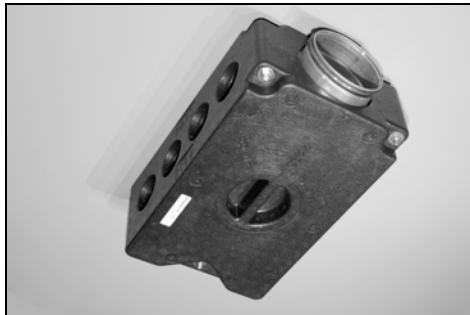

Step 4:

- Install the distributors.
- When installing the air distributors, include an opening to allow service accessibility.
- Connect the flexible steel ducts. (Close off unused openings with a cap.)

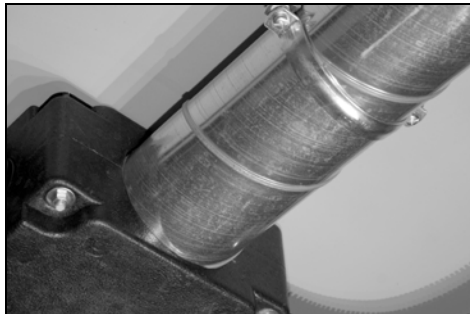

Step 5:

- Install the folded spiral-seams ducts and sound absorbers and connect them to the distributors and the central unit.



**Step 6:**

- Install the grilles and / or roof hoods for the outgoing air and outside air.
- Where breaking through the roof, make sure no condensation can penetrate from the outside or be produced in the roof shell.
- Use an exterior grille with fly screen.

**Step 7:**

- Install the supply and exhaust air valves.

Step 8:

- Start up the ventilation system as described in **section 6**.

Installation



5.3. Installation procedure for renovation projects



Step 1:

- Mount the distributors at the intended locations.



Step 2:

- Fit the duct clamps on the ceiling.
- The distance between the clamps should be max. 0.75 m.



Step 3:

- Connect the flexible steel ducts to the distributors and secure them in the clamps.



Step 4:

- Install the central unit at its intended location.
- Fit the siphon.

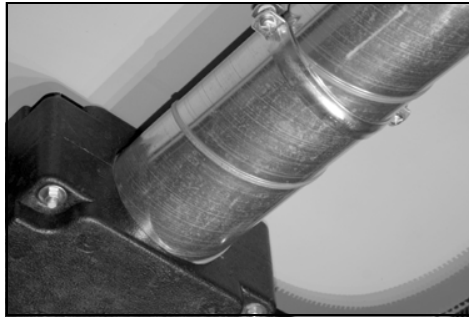

Step 5:

- Install the folded spiral-seam ducts and sound absorbers and connect them to the distributors and the central unit.



Step 6:

- Install the grilles and / or roof hoods for the outgoing air and outside air.
- Where breaking through the roof, make sure no condensation can penetrate from the outside or be produced in the roof shell.
- Use an exterior grille with fly screen.



Step 7:

- Install the supply and exhaust air valves and connect them to the flexible steel ducts.



Step 8:

- Start up the ventilation system as described in **section 6**.

6. Commissioning

Before setting up, check that

- all filters and valves are correctly fitted,
- all through-flow openings have been executed,
- the electrical connections are correctly executed,
- ventilation ducts are correctly insulated,
- the condensation connection is correctly executed, and all shutters, regulators and (where appropriate) fire protection shutters are open.

To set up the room air unit a suitable air flow meter, such as a vane impeller anemometer with measuring hopper, is required.

Pay attention to the tolerances of the measuring device and the measurement inaccuracies!

Setup procedure:

- Set the fan speeds to the calculated air flows in the unit, following the installation and operating instructions provided for the unit.
- Set the fan speed assigned to the nominal ventilation.
- Fully open all valves.
- Start the regulation process with the valve farthest away from the central unit.
- Carry out a control measurement of all valves.
- Adjust the valves until the air flow is reached.

All data obtained and all settings made must be documented.

The installation and maintenance instructions must be left with the operators.

The contractor may offer the operators a service contract.

7. Maintenance and cleaning

7.1. Maintenance of the central unit

You will find the relevant protocol templates on the website under Service / Download product documentation.



For details of the maintenance procedures and how to implement them, refer to the relevant operating instructions for the central unit.

Pay particular attention to the safety instructions included in the respective instruction manuals.

The following maintenance procedures should be carried out at the stipulated intervals:

Maintenance interval	Procedure
Half-yearly	- Replace filter (class G4)
Yearly	- Depending on the degree of dirtying, we recommend cleaning the heat exchanger once a year
	- Depending on the degree of dirtying, we recommend cleaning the interior of the unit once a year
	- Depending on the room temperatures and the degree of dirtying, we recommend cleaning the siphon once a year

7.2. Cleaning the MAICOFlex duct system

Cleaning set

The cleaning set comprises a vacuum cleaner adapter and two cleaning balls, and is available in three different diameters matching the flexible ducts.

Cleaning procedure

Starting from the air distributor, insert a cleaning ball into the duct and draw it out of the other end using a vacuum cleaner. The cleaning ball carries dirt residues with it as it passes through.

Safety instructions

- Keep the instruction manual in a safe place.
- Carry out cleaning once a year.
- When cleaning is complete, ensure that there are **no** cleaning balls left in the duct system.

Cleaning

- Clean ventilation ducts once a year.
- Use an industrial vacuum cleaner if possible.
- Carry out the cleaning procedure **repeatedly** on each duct.
- In large building complexes, have cleaning of exhaust air and supply air ducts carried out by a janitor.
- Clean dirty cleaning balls with standard commercially available washing-up liquid.

Cleaning a duct

- Remove the service cap (bayonet lock, 45°) from the air distributor – see also "open / close" marking on housing. (Depending on the installation, the DN 125 service cap may be at the front, on the top or on the bottom.)
- Remove the exterior grille at the other end of the duct.

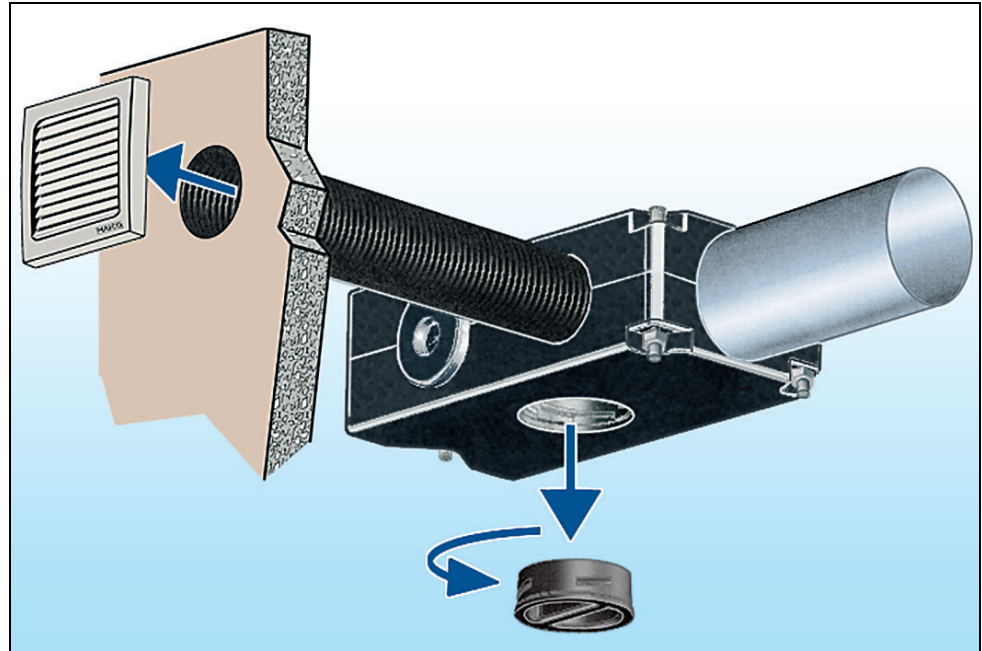

- Insert the cleaning adapter.
- Fit the vacuum cleaner hose into the hopper of the cleaning adapter so that it seals flush.

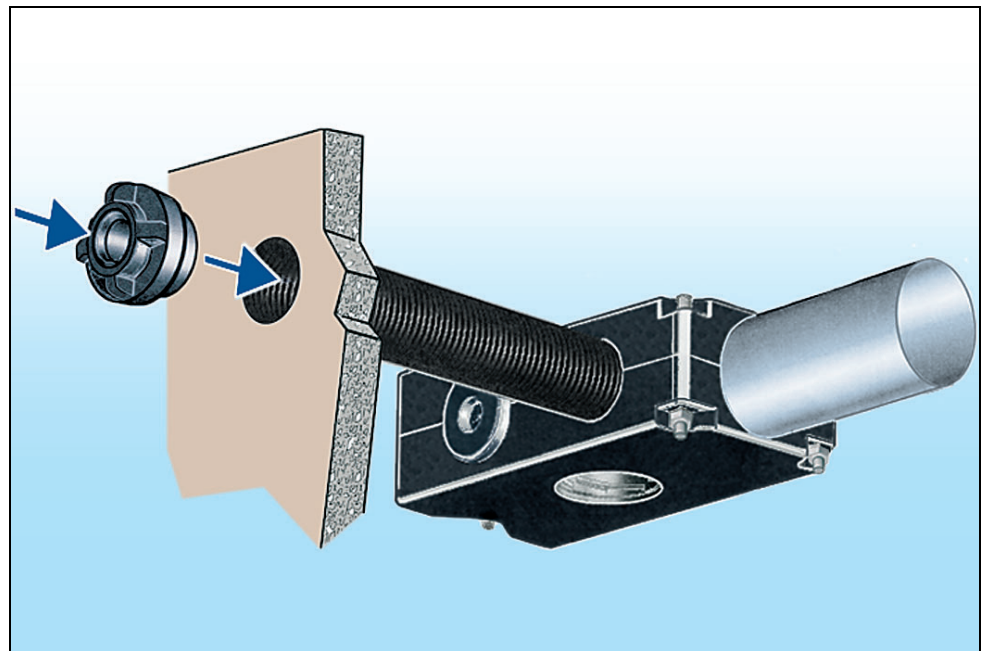

- Switch on the vacuum cleaner.
- Insert a matching cleaning ball into the duct being cleaned inside the air distributor.
- The cleaning ball is drawn in until it is flush with the cleaning adapter.
- Detach the cleaning adapter.
- Switch off the vacuum cleaner.
- Take out the cleaning ball.
- Remove dirt from the duct.
- Clean the cleaning ball.
- Carry out the cleaning procedure repeatedly on each duct.

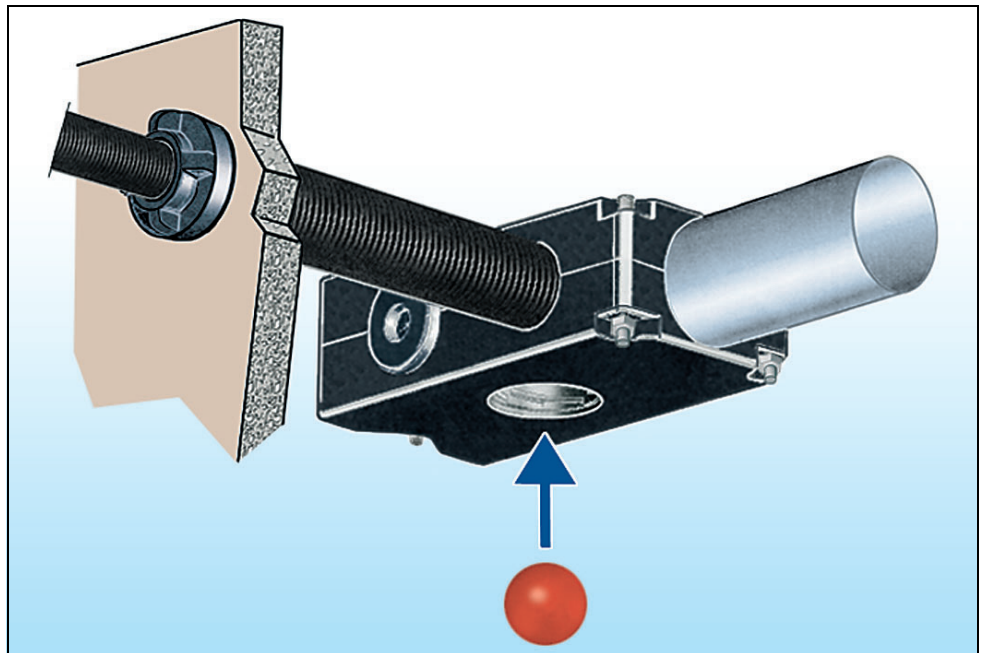

- Fit the exterior grille and service cap.

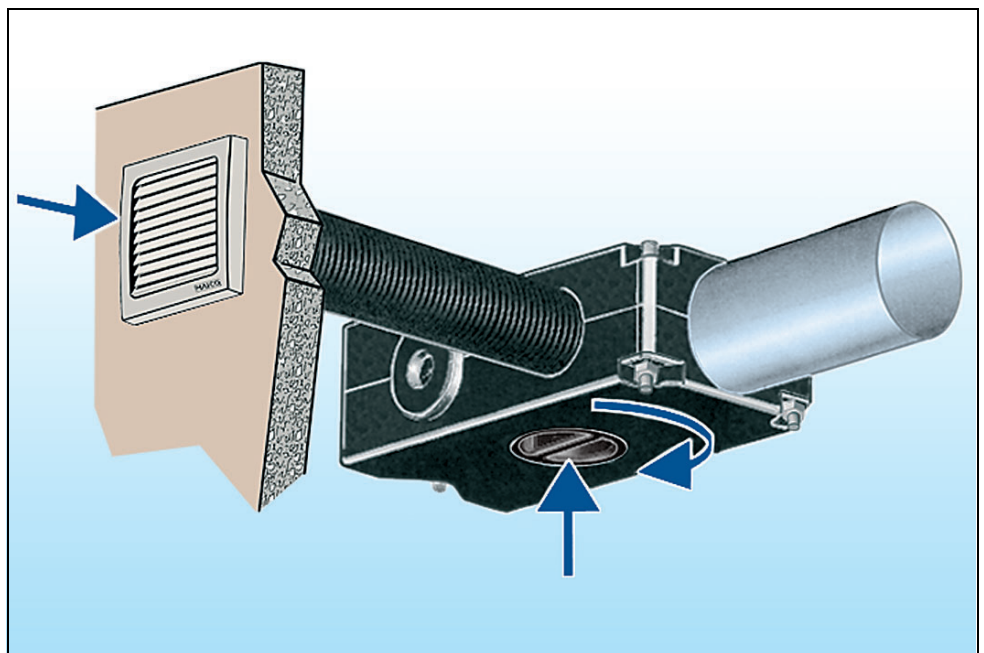



Your advantages

- As an option in case of renovation, no duct laying required.
- THE solution for individual rooms.
- Adaption to different requirements by individual ventilation control in each room.
- Low energy consumption, saves money and protects the environment.
- Reasonably-priced alternative to central systems.

Short description

- Decentralised supply and exhaust air unit with heat recovery.
- Supply air is heated using heat recovered from the exhaust air flow.
- Special energy savings due to the DC motor.
- Quick and easy to install using a core hole.
- The system requires no adjustment.
- Very flat, timeless design.

Application examples

- Apartment
- Renovation
- Flat occupying the whole of one floor
- Tenant apartment
- Single family-unit house
- Multiple family unit
- Office

Details

Wiring diagram	www.maico-fans.com
Assembly instruction	www.maico-fans.com
Product data sheet	www.maico-fans.com

Functional description

- The new, decentralised WRG 35 ventilation unit with heat recovery delivers controlled ventilation and air extraction for living rooms.
- Unlike solutions with centralised units, here a unit is fitted in each of the rooms requiring ventilation. This eliminates the need for the costly installation of a duct system. The WRG 35 is therefore the ideal ventilation solution for any redevelopment project – especially when space is at a premium. The compact dimensions of the WRG 35 unit allow it to be easily fitted into the wall using a core hole if there is little space available.
- Ventilation in every room can be set individually by installing the individual units in a decentralised manner.

Mode of operation

- Fresh draft-free and filtered air flows across an aluminium cross flow heat exchanger into living rooms and bedrooms, while stale air, moisture and bad odours are safely and reliably extracted to the outside, preventing the formation of mould and damage to the building.
- In the process the heat in the exhaust air is transferred to the incoming fresh air in the heat exchanger. Up to 70 % of the heat can be recovered and reused. The standard G4 filter ensures clean air. F7 filters can also be retrofitted to protect allergy sufferers from inconvenient reactions. The overall result is a pleasantly fresh indoor environment.
- Thanks to electric external shutters, cold air cannot flow in when the unit is switched off.

Features

- Simultaneous ventilation and air extraction possible.
- If necessary, pure supply air or exhaust air operation can also be set.
- With 2 integrated G4 filters, F7 filter optional.
- No disturbing parts inside, just a flat designer cover.
- Housing and wall sleeve made entirely from noise-insulating EPP, which makes them particularly well suited to living rooms and bedrooms.
- Cold air does not flow in when the unit is switched off thanks to electric external shutters.
- Optional accessories make it suited to various wall thicknesses.

Heat recovery fan

- 2 axial DC fans. One fan each for supply air and exhaust air.
- 4 ventilation steps **with** heat recovery:
 - 1 = minimum ventilation (17 m³/h)
 - 2 = normal ventilation (30 m³/h)
 - 3 = intensive ventilation 1 (45 m³/h)
 - 4 = intensive ventilation 2 (60 m³/h)
- Other ventilation levels **without** heat recovery:
 - Supply air only (30 m³/h).
 - Exhaust air only (30 m³/h).

Mounting instructions

- Assembly involves 2 steps:
- Fitting WRG 35-SR shell kit in a DN 360 core hole.
- Integration of WRG 35-SE final assembly set.
- The shell kit's wall sleeve is protected from contamination by plaster protective covers.
- The drilling template supplied simplifies the process of installing the external cover.
- The covers are easy to remove.
- No need to lay ducts.
- The system requires no adjustment.

The components of the decentralised WRG 35 air unit with heat recovery:

Needed:

- Set for final WRG 35-SE assembly.
- Complete fan unit.
- Internal cover included.
- Set for WRG 35-SR shell.
 - Scope of delivery: wall sleeve (3 parts), 2 plaster protective covers, reinforced cross with stop for spirit level and stainless steel external cover with drilling template.
- RLS 4 AP room air control (surface-mounted) or RLS 4 UP room air control (recess-mounted). The WRG 35 is activated by the RLS 4 room air control.

Optional:

- WRG 35-VH extension sleeve
 - Scope of delivery: extension sleeve, 2 separating bridges and condensation hose.
- WRG 35-AR compensating frame.
- WRG 35-G4 replacement filter.
- WRG 35-F7 replacement filter.

Decentralised ventilation WRG 35

Final assembly kit WRG 35-SE



- Complete fan unit for decentralised WRG 35 ventilation unit with heat recovery, including internal cover and 2 G4 filters.
- Accessories needed:
WRG 35 SR shell kit and
RLS 4 control

Article	Art. No.
WRG 35-SE	0082.0233

Common features

Air flow volume	17 / 30 / 45 / 60 m ³ /h
Power consumption	2 / 4 / 6 / 8 W
Sound pressure level in 3 m distance	18 / 22 / 29 / 30 dB (A)
Rated max. element normal difference in noise level D_{NE}	39 dB (A)
Heat recovery rate	> 70 %

Shell kit WRG 35-SR



- Shell kit for fitting in the wall.
- Scope of delivery: wall sleeve (3 parts), 2 plaster protective covers, reinforced cross with stop for spirit level and stainless steel external cover with drilling template.
- Is needed as accessory for WRG 35-SE.

Common features

Maximum airstream temperature	40 °C
Material	Plastic EPP

Article	Art. No.
WRG 35-SR	0192.0450

Room air control RLS 4



- Room air control for decentralised ventilation unit with heat recovery WRG 35.
- The following ventilation levels can be selected: Ventilation levels 1 to 4 - from low when people are out during the day to high for a rapid air exchange.
- Supply air mode, i.e. supply air operation only at 30 m³/h (e.g. for cooling at night).
- Exhaust air mode, i.e. exhaust air operation only at 30 m³/h (e.g. cross ventilation per living unit)

- To achieve this, the WRG 35 is e.g. switched to supply air mode in the bedroom and to exhaust air mode in the living room.

- Accessories supplied: 5 m connecting duct.
- Is needed as accessory for WRG 35-SE.

Article	Art. No.	Type of installation	Degree of protection (IP)
RLS 4 AP	0157.0843	Surface-mounted	00
RLS 4 UP	0157.0844	Recessed-mounted	00

Extension sleeve WRG 35-VH



- Extension to wall sleeve from decentralised WRG 35 ventilation unit with heat recovery.
- Scope of delivery: extension sleeve, 2 separating bridges and condensation hose.

Common features

Maximum airstream temperature	40 °C
Material	Plastic EPP

Article	Art. No.
WRG 35-VH	0192.0451

Compensating frame WRG 35-AR



- Compensating frame for WRG 35 decentralised ventilation unit with heat recovery.
- The compensating frame is needed if the wall is thinner than 350 mm and the shell kit (wall sleeve) therefore protrudes too far out of the wall such that the outer cover can no longer be fitted. The outer wall must however be at least 251 mm thick.

Common features

Maximum airstream temperature	40 °C
Material	Plastic EPP

Article	Art. No.
WRG 35-AR	0192.0454

Air filter, replacement WRG 35

- Replacement air filter for decentralised WRG 35 ventilation unit with heat recovery.
- Easy filter change.

Article	Art. No.	Filter	Packing unit
WRG 35-G4	0192.0452	G4	2 pieces
WRG 35-F7	0192.0453	F7	1 pieces



Your advantages

- Compact, space-saving device thanks to left-hand resp. right-hand version.
- High degree of heat provision saves energy and costs.
- Very quiet operation.

Short description

- Very quiet centralised ventilation and extraction system.
- Supply and exhaust air device with heat recovery.
- For apartments up to approx. 120 m².
- Automatic volumetric flow balancing.
- Up to 165 m³/h at a maximum 68 W power consumption.
- Easy filter change.

Application examples

- Low energy house
- Living room
- Apartment
- Single family-unit house
- Passive energy house

Models

- WS 150 L: For left-hand building connections (exhaust air, supply air).
- WS 150 R: For right-hand building connections (exhaust air, supply air).

Features

- Automatic constant volume regulation for equal air quantities.
- Special energy savings due to the DC motor.
- Powder-coated plate housing in sandwich construction, with integrated heat insulation.
- Integrated filter system with coarse filter (G4) in the outside air and in the exhaust air. Filter change is possible without tools.
- Every 2 DN 125 duct connections with rubber lip seals, on side walls of unit. For directly connecting up tubular sound absorbers.
- Controlled through RLS 2 F control unit in the living room.
- Operator unit for switching fan steps, timer, filter pollution.
- Control unit not included in scope of delivery.

Heat exchanger

- Counterflow heat exchanger made of aluminium.
- The heat exchanger can be easily removed and cleaned with water.

Heat recovery fan

- 2 centrifugal DC fans, one fan each for supply air and exhaust air.
 - 3 ventilation steps selectable:
 - 1 = Economy setting: **70** , 85, 95, 105 m³/h
 - 2 = Normal: 85, **100** , 120, 135 m³/h
 - 3 = Intensive ventilation: 120, **135** , 150, 165 m³/h
- Values printed bold = Factory setting

Mounting instructions

- Mounting on the wall or a pedestal is required to ensure access to the condensation connection.
- The front plate can be hinged open after loosening the 2 quick-release clips.
- Decouple the housing with impact sound plates for sound insulation.

Condensation drain

- Condensation is drained out at the bottom of the unit. Condensation drainage (3/4" external thread) for connection to a 1/2" hose.

Anti-frost protection

- Frost protection by switching off the supply air fans.
- The frost protection feature switches the supply air fan off when the heat exchanger starts to freeze up.
- If the outgoing air temperature is higher, the frost protection feature is switched off.
- Always combine heat recovery systems with earth heat exchangers, in order to be able to guarantee trouble-free operation, even at very low temperatures. Furthermore, an earth heat exchanger guarantees additional heater power rating in winter and additional cooling power in summer.

Details

Characteristic curve	P. 41
Accessory	P. 62
Wiring diagram	www.maico-fans.com
Assembly instruction	www.maico-fans.com
Product data sheet	www.maico-fans.com

Article	Art. No.	Degree of heat provision %	U _{nom} V	Connection diameter mm	Air flow volume m ³ /h	T _{Max} at I _{Max} °C	Filter class	Degree of protection (IP)	Weight kg
WS 150 L	0095.0058	90	230	125	165	50	G4	00	53
WS 150 R	0095.0057	90	230	125	165	50	G4	00	53

Article	Art. No.	Colour	Heat exchanger construction type
WS 150 L	0095.0058	Sheet steel, galvanised Light grey	Cross-counterflow
WS 150 R	0095.0057	Sheet steel, galvanised Light grey	Cross-counterflow

Dimensions [mm]

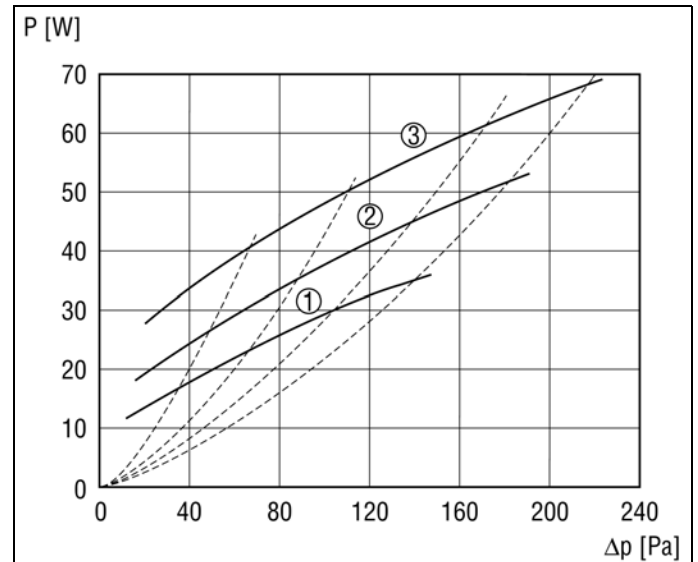
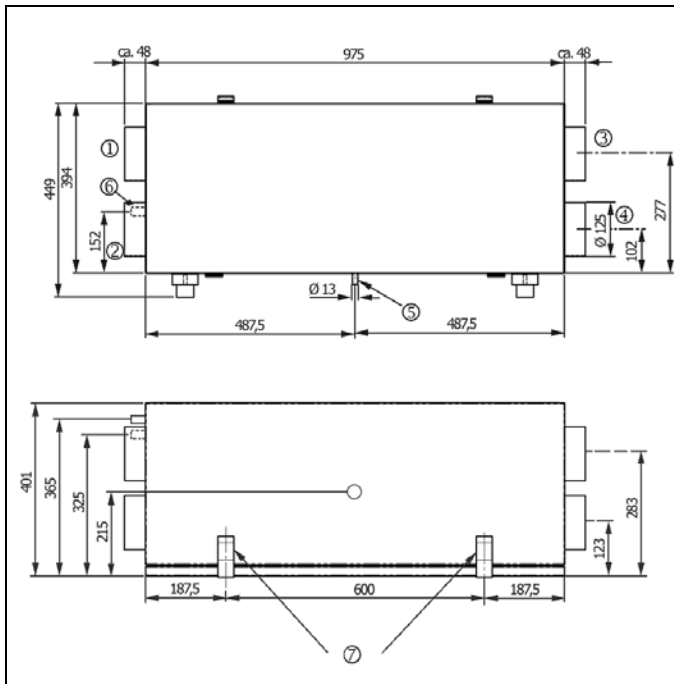

① Step 1 = 70 m³/h ② Step 2 = 100 m³/h ③ Step 3 = 135 m³/h

Connections on the left

- ① Exhaust air
- ② Supply air
- ③ Outside air
- ④ Outgoing air
- ⑤ Condensation drain
- ⑥ Electrical connections
- ⑦ Seal

Connections on the right

- ① Outside air
- ② Outgoing air
- ③ Exhaust air
- ④ Supply air
- ⑤ Condensation drain
- ⑥ Electrical connections
- ⑦ Seal

Sound power level in the octave range (level 2)

	63 Hz	125 Hz	250 Hz	500 Hz	1 kHz	2 kHz	4 kHz	8 kHz	Total
L _{WA2} [dB(A)]		28	26	28	22	19	9	5	33
L _{WA5} [dB(A)]		24	22	28	28	21	11	5	33
L _{WA6} [dB(A)]		22	24	28	28	25	10	5	33

L_{WA2} = housing sound pressure level in dB.

L_{WA5} = free inlet sound pressure level in dB.

L_{WA6} = free outlet sound pressure level in dB.

Recommended accessories	WS 150 L	WS 150 R	see
MAICOFlex duct system	MAICO Flex duct system	MAICO Flex duct system	P. 54
Brine earth heat exchanger	EW	EW	P. 58
External grille	SG 100, SG 100 B, SG 120	SG 100, SG 100 B, SG 120	www.maico-fans.com
Stainless steel cowl	LH-V2A 10, LH-V2A 12	LH-V2A 10, LH-V2A 12	www.maico-fans.com
Internal grille	ESG 10/2	ESG 10/2	www.maico-fans.com
Internal grille, adjustable	AZE 100, AZE 100 P	AZE 100, AZE 100 P	P. 62
Roof cowl	DF, DP, BS, RG	DF, DP, BS, RG	www.maico-fans.com
Disk valve, synthetic material	TK 10, TK 12	TK 10, TK 12	P. 62
Stainless steel disk valve	TM-V2A 10, TM-V2A 12	TM-V2A 10, TM-V2A 12	www.maico-fans.com
Disk valve, metal	TFA 10, TFA 12, TFZ 10, TFZ 12	TFA 10, TFA 12, TFZ 10, TFZ 12	www.maico-fans.com
Blower nozzle	WD 10 D, WD 10 W	WD 10 D, WD 10 W	P. 63
Door ventilation grille	MLK 30 white, MLK 45 white	MLK 30 white, MLK 45 white	P. 63
Tubular sound absorber	RSR 12, RSR 10/50, RSR 12/50	RSR 12, RSR 10/50, RSR 12/50	www.maico-fans.com
Electrical air heater	ERH 12-1	ERH 12-1	www.maico-fans.com
Water air heater	WRH 12-1	WRH 12-1	www.maico-fans.com
Air filter	TFE 12-4, TFE 12-5, TFE 12-7	TFE 12-4, TFE 12-5, TFE 12-7	www.maico-fans.com
Air filter, replacement	WSG 150	WSG 150	P. 67
Wall bracket	WSK150	WSK150	P. 67
Summer cassette	SK 150	SK 150	P. 69
Air quality controller	EAQ 10/1	EAQ 10/1	www.maico-fans.com
Room air control	RLS 2 F	RLS 2 F	P. 68



Your advantages

- High degree of heat provision saves energy and costs.
- Operation with fireplaces is possible (in accordance with ZIV criteria).
- Passive house approval for highest quality.
- Intelligent controller supplied.
- Bypass enables ventilation with cooler outside air in summer.
- Integrated anti-frost protection heating ensures supply air operation, even when there is a danger of frost.

Short description

- Supply and exhaust air device with heat recovery.
- For single family-unit houses up to approx. 200 m².
- Also recommended for passive houses.
- Automatic volumetric flow balancing.
- Constant volumetric flow.

Application examples

- Low energy house
- Single family-unit house
- Passive energy house



Features

- Automatic constant volumetric flow regulation for equal air quantities.
- Special energy savings due to the DC motor.
- Galvanised plate housing, RAL 9010 plastic powder coated surface, sandwich construction, with integrated heat insulation.
- Integrated filter system with coarse filter (G4) and dust filter (F7) fitted in the outside air, coarse filter (G4) fitted in the exhaust air. Filter change is possible without tools.
- Electronic filter monitoring with filter change warning displayed on the operator unit.
- 4 DN 160 duct connections with rubber lip seals on top of the unit. For directly connecting up tubular sound absorbers.
- Air distribution bypass / heat exchanger = 70 % / 30 %.
- Controlled from the operator unit in the living room.
- Operator unit for switching fan steps, timer, filter pollution.
- With DIBT approval (The German Institute for Building Technology).

Heat exchanger

- Counterflow heat exchanger made of synthetic material (PS).
- The heat exchanger can be easily removed and cleaned with water.

Heat recovery fan

- 2 centrifugal DC fans with integrated converter, one fan each for supply air and exhaust air. Adjustable in 5 m³/h steps from 100 m³/h up to 250 m³/h.
- 3 ventilation steps:
1 = Economy setting/Night operation
2 = Normal / Daytime operation
3 = Intensive / party operation
Factory setting: 100 m³/h / 150 m³/h / 200 m³/h

Operator unit for WS 250

- The WS 250 room air system is remotely controlled using a separate operator unit. The ventilation levels or day/week programs etc. can therefore be set.
- The operator unit is connected to the central device using a shielded 5-core cable. It has a maximum length of 100 m. The operator unit can then be fitted virtually anywhere in a detached single-family unit house.
- Dimensions of operator unit:
Width: 150 mm
Height: 80 mm
Depth: 32 mm



Mounting instructions

- Mounting on the wall or a pedestal is required to ensure access to the condensation connection.
- For installation or wall fitting using a bracket: In cellars, attics and engineering rooms.
- The front plate can be unscrewed.
- Decouple the housing with impact sound plates for sound insulation.

Electrical connection

- The attached operator unit is connected to the central unit via a 5-core, screened cable (maximum length 100 m).

Condensation drain

- Condensation is drained out at the bottom of the unit using a hose (DN 1/2") connected to a siphon.

Anti-frost protection

- Integrated defroster heating component (1500 W) for trouble-free and frost-free operation.
- Always combine heat recovery systems with earth heat exchangers, in order to be able to guarantee trouble-free operation, even at very low temperatures. Furthermore, an earth heat exchanger guarantees additional heater power rating in winter and additional cooling power in summer.

Details

Characteristic curve	P. 43
Accessory	P. 62
Wiring diagram	www.maico-fans.com
Assembly instruction	www.maico-fans.com
Product data sheet	www.maico-fans.com

Article	Art. No.	Degree of heat provision %	U _{nom} V	Connection diameter mm	Rotating speed 1/min	Air flow volume m ³ /h	P _{nom} W	I _{Max} A	T _{Max} at I _{Max} °C	Filter class	Degree of protection (IP)	Weight kg
WS 250	0095.0050	92	230	160	2,070	250	95/50/30	6,9 ¹⁾	50	G4/F7	00	80

Article	Art. No.	Colour	Heat exchanger construction type
WS 250	0095.0050	Sheet steel, galvanised	Pure white, similar to RAL 9010
			Cross-counterflow

1) Including defroster heating

Dimensions [mm]

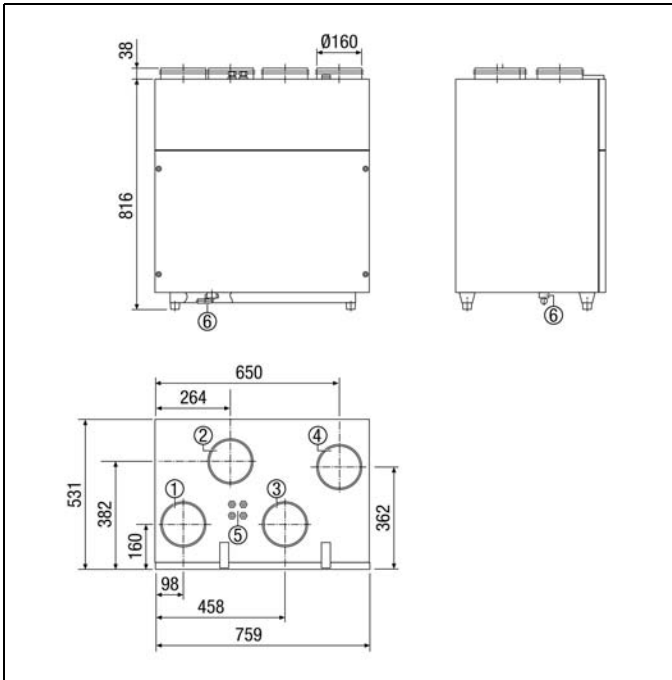

- ① Outgoing air
- ② Supply air
- ③ Exhaust air
- ④ Outside air
- ⑤ Electrical connection
- ⑥ Condensation connection

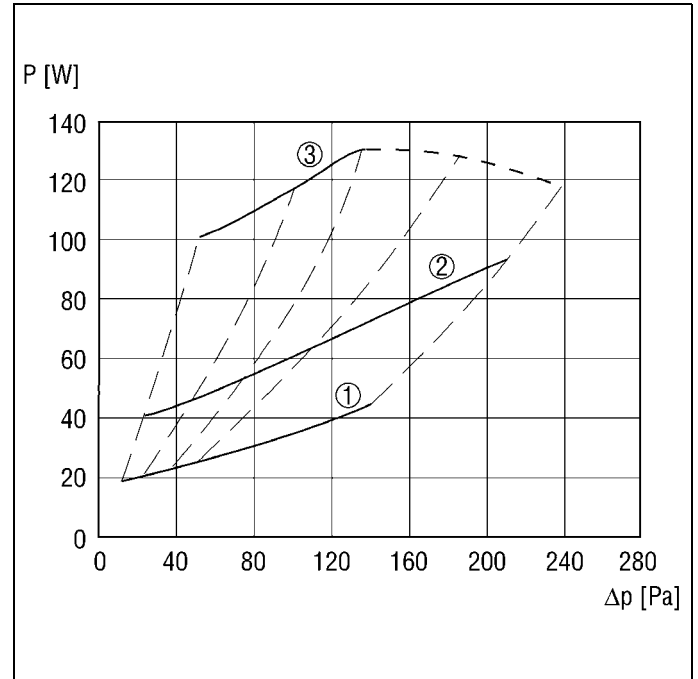

- ① Step 1: 100 m³/h
- ② Step 2: 150 m³/h
- ③ Step 3: 250 m³/h

Sound power level in octave range (Step 2)

	63 Hz	125 Hz	250 Hz	500 Hz	1 kHz	2 kHz	4 kHz	8 kHz	Total
L _{WA2} [dB(A)]	34	29	33	24	22	20	16	38	
L _{WA5} [dB(A)]	37	39	40	40	40	34	26	48	
L _{WA6} [dB(A)]	27	26	31	39	26	17	8	41	

L_{WA2} = housing sound pressure level in dB.
 L_{WA5} = free inlet sound pressure level in dB.
 L_{WA6} = free outlet sound pressure level in dB.

Measured at V: 150 m³/h (<30Pa)

Recommended accessories	WS 250	see
MAICOFlex duct system	MAICO Flex duct system	P. 54
Brine earth heat exchanger	EW	P. 58
Stainless steel cowl	LH-V2A 10, LH-V2A 12	www.maico-fans.com
Internal grille	ESG 10/2	www.maico-fans.com
Internal grille, adjustable	AZE 100, AZE 100 P	P. 62
Roof cowl	DF, DP, BS, RG	www.maico-fans.com
Disk valve, synthetic material	TK 10, TK 12	P. 62
Stainless steel disk valve	TM-V2A 10, TM-V2A 12	www.maico-fans.com
Disk valve, metal	TFA 10, TFA 12, TFZ 10, TFZ 12	www.maico-fans.com
Blower nozzle	WD 10 D, WD 10 W	P. 63
Door ventilation grille	MLK 30 white, MLK 45 white	P. 63
Tubular sound absorber	RSR 16, RSR 10/50, RSR 12/50, RSR 16/50	www.maico-fans.com
Electrical air heater	ERH 16-2	www.maico-fans.com
Water air heater	WRH 16-2	www.maico-fans.com
Air filter	TFE 16-4, TFE 16-5, TFE 16-7	www.maico-fans.com
Air filter, replacement	WSF 250, WSG 250	P. 67
Wall bracket	WSK 250	P. 67
Hygrostat	HY 5, HY 5 I	www.maico-fans.com
Air quality controller	EAQ 10/1	www.maico-fans.com
Air flow monitor	LW 9	www.maico-fans.com



Your advantages

- High degree of heat provision saves energy and costs.
- Central control unit enables convenient control of the device from the living room (contained in the scope of delivery).
- The integrated bypass provides cooling in summertime.

Short description

- Supply and exhaust air unit with heat recovery.
- For large, single family-unit houses up to approx. 400 m².
- Automatic volumetric flow balancing
- Up to 550 m³/h at a maximum 220 W power consumption.
- Intelligent controller supplied.

Application examples

- Low energy house
- Apartment
- Single family-unit house
- Office

Features

- Automatic constant volumetric flow regulation for equal air quantities.
- Special energy savings due to the DC motor.
- Integrated filter system with coarse filter (G4) in the outside air and in the exhaust air. Filter change is possible without tools.
- Electronic filter monitoring with filter change warning displayed on the operator unit.
- 4 DN 225 duct connections with with rubber lip seals. Of which 2 are on the top of the unit and 1 is fitted on each side wall. For directly connecting up tubular sound absorbers.
- Controlled from the operator unit in the living room.
- Operator unit for switching fan steps, timer, filter pollution.

Heat exchanger

- Counterflow heat exchanger made of aluminium.
- The heat exchanger can be easily removed and cleaned with water.

Heat recovery fan

- 2 centrifugal DC fans, one fan each for supply air and exhaust air.
- 3 ventilation steps:
 - 1 = Basic ventilation/Night operation
 - 2 = Normal / Daytime operation
 - 3 = Intensive / Party operation
 Factory setting: 270 m³/h / 350 m³/h / 450 m³/h

Control unit

- The room air system WS 600 is remote-controlled by a separate control unit. With this control unit ventilation steps or day and week time programmes can be set.
- The control unit is connected to the central device is by a screened 5-wire connection with a maximum length of 100 m. This means, that the control unit can be installed in any place of a single-family house.



Mounting instructions

- The front plate can be hinged open for changing the filter.
- Allow for sufficient space at the side walls when installing.
- Decouple the housing with impact sound plates for sound insulation.

Electrical connection

- The attached operator unit is connected to the central unit via a 5-core, screened cable (maximum length 100 m).

Condensation drain

- Condensation is drained from the side of the unit using a hose (DN 1/2") connected to a siphon.

Anti-frost protection

- Always combine heat recovery systems with earth heat exchangers, in order to be able to guarantee trouble-free operation, even at very low temperatures. Furthermore, an earth heat exchanger guarantees additional heater power rating in winter and additional cooling power in summer.

Details

Characteristic curve	P. 45
Accessory	P. 62
Wiring diagram	www.maico-fans.com
Assembly instruction	www.maico-fans.com
Product data sheet	www.maico-fans.com

Article	Art. No.	Degree of heat provision %	U_{nom} V	Connection diameter mm	Rotating speed 1/min	Air flow volume m ³ /h	I_{Max} A	T_{Max} at I_{Max} °C	Filter class	Degree of protection (IP)	Weight kg
WS600	0095.0056	90	230	224	2,070	550	1	50	G4	00	100
Article	Art. No.	Sheet steel, galvanised			Colour Light grey			Heat exchanger construction type Cross-counterflow			
WS600	0095.0056	Sheet steel, galvanised			Light grey			Cross-counterflow			

Dimensions [mm]

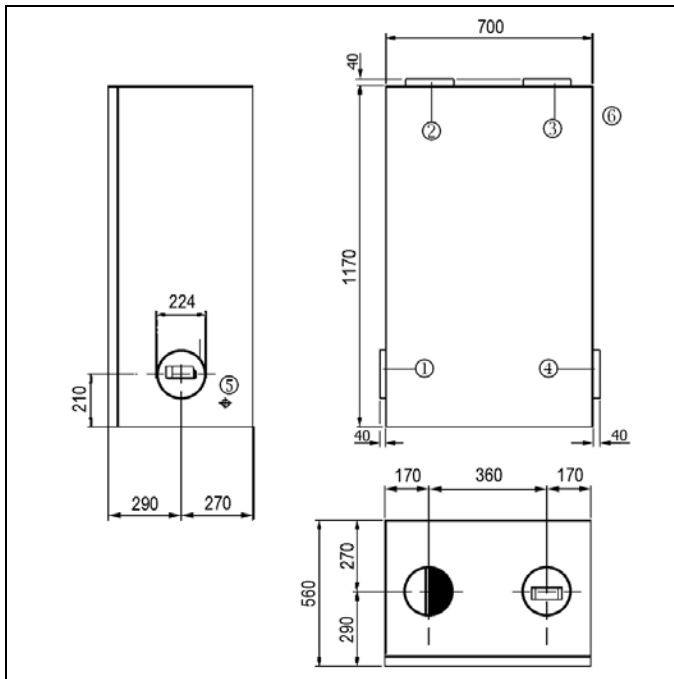

- ① Outside air
- ② Exhaust air
- ③ Supply air
- ④ Outgoing air
- ⑤ Condensation connection
- ⑥ Electrical connection

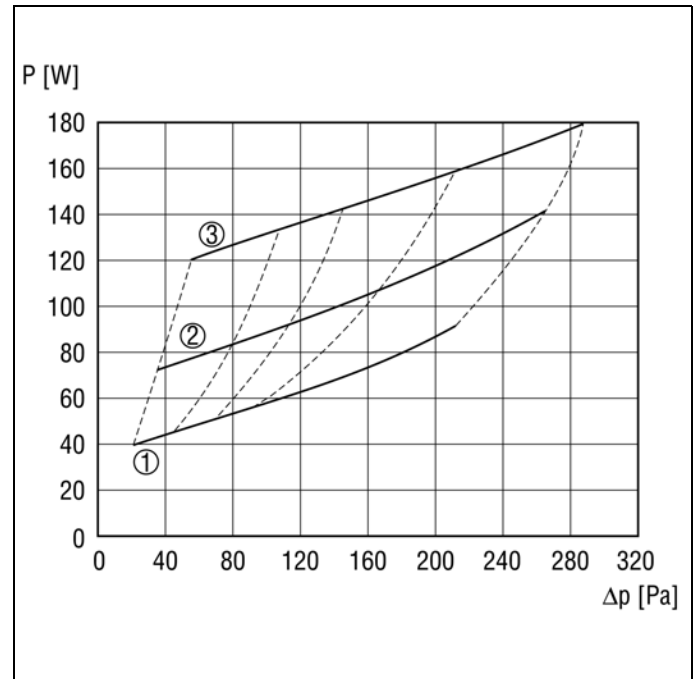

- ① Step 1 = 200 m³/h
- ② Step 2 = 300 m³/h
- ③ Step 3 = 400 m³/h

Sound power level in the octave range (level 2)

	63 Hz	125 Hz	250 Hz	500 Hz	1 kHz	2 kHz	4 kHz	8 kHz	
L_{WA2} , high [dB(A)]	48	46	38	32	33	36	28	51	
L_{WA5} , high [dB(A)]	40	39	39	39	20	15	5	46	
L_{WA6} , high [dB(A)]	51	54	58	59	44	39	40	63	

L_{WA2} = housing sound pressure level in dB.

L_{WA5} = free inlet sound pressure level in dB.

L_{WA6} = free outlet sound pressure level in dB.

Recommended accessories	WS600	see
MAICOFlex duct system	MAICO Flex duct system	P. 54
Brine earth heat exchanger	EW	P. 58
Stainless steel cowl	LH-V2A 10, LH-V2A 12	www.maico-fans.com
Internal grille	ESG 10/2	www.maico-fans.com
Internal grille, adjustable	AZE 100, AZE 100 P	P. 62
Roof cowl	DF, DP, BS, RG	www.maico-fans.com
Disk valve, synthetic material	TK 10, TK 12	P. 62
Stainless steel disk valve	TM-V2A 10, TM-V2A 12	www.maico-fans.com
Disk valve, metal	TFA 10, TFA 12, TFZ 10, TFZ 12	www.maico-fans.com
Blower nozzle	WD 10 D, WD 10 W	P. 63
Door ventilation grille	MLK 30 white, MLK 45 white	P. 63
Tubular sound absorber	RSR 20, RSR 10/50, RSR 12/50, RSR 20/50	www.maico-fans.com
Electrical air heater	ERH 20-2	www.maico-fans.com
Water air heater	WRH 20-2	www.maico-fans.com
Air filter	TFE 20-4, TFE 20-5, TFE 20-7	www.maico-fans.com
Air filter, replacement	WSG 600	P. 67



Your advantages

- High degree of heat provision saves energy and conserves the resources.
- Energy-saving CD motors help saving your money.
- Protection against pollen in the room thanks to G4 and F7 filters.
- 4 ventilation steps for demand-oriented ventilation and air extraction.
- Passive house approval for highest quality.
- Very quiet operation.

Short description

- Supply and exhaust air unit with heat recovery.
- For single family-unit houses up to approx. 300 m².
- 300 m³/h for WR 300 and 400 m³/h for WR 400.
- Highly effective aluminium heat exchanger.
- Constant volumetric flow.
- RLS 1 WR modern operator unit is included in the scope of delivery as standard.
- EPP internal housing: quiet and with particularly good thermal insulation.
- EIB-KNX Bus connection possible.

Application examples

- Low energy house
- Single family-unit house
- Passive energy house



Features

- Special energy savings due to DC motors having EC technology.
- With sound insulated fans for especially quiet running.
- With automatic volumetric flow regulation for constant air quantities.
- Internal housing of heat resistant synthetic material, non-hygroscopic.
- Easy filter change.
- With two integrated G4 filters and an F7 filter, filters can be changed without tools.
- 4 DN 160 duct connections with double lip seal on top of the unit. For directly connecting up tubular sound absorbers.
- Summer cassette as accessories.

Control unit

- RLS 1 WR operator unit with message indicating a filter change.
- Set the 4 ventilation levels using buttons.
- Display flows.
- Other operator units can be connected in parallel.

Heat exchanger

- Counterflow plate heat exchanger made of aluminium.
- The heat exchanger can be removed easily once the front plate has been unscrewed.
- The heat exchanger can be easily cleaned using water.

Heat recovery fan

- 2 centrifugal DC fans, one fan each for supply air and exhaust air.
- Fans with centrifugal impellers curved to the front.
- 4 ventilation steps:
I = Interval / vacation operation for humidity protection
1 = Reduced ventilation
2 = Nominal ventilation
3 = Intensive / party operation
- The air volume is linearly adjustable.
- 300-type fans can be easily swapped for 400-type fans.
- Fans are located behind the heat exchanger in the outside or outgoing air.

Function of the interval operation:

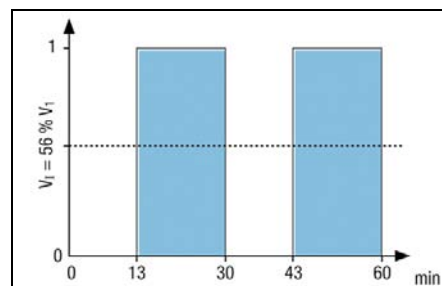

Switching level 1 (reduced ventilation) on and off twice results in a very low exchange of air in the interval level. It takes 17 minutes to switch on and 13 minutes to switch off. The unit therefore runs for 34 min (56 %) an hour.

Mounting instructions

- Feet for installation.
- Must be mounted on the wall or a pedestal to ensure access to the condensation connection.
- Housing covers can be unscrewed.
- Connect air channels and condensation drainage prior to commissioning.
- Sound absorbers on the inlet and outlet side are recommended.

Electrical connection

- When delivered, the device is assembled and ready for service.
- Connection of CO₂ sensors or hygrostat e.g. HY5 possible. Automatic switching from stage 2 to stage 1 or stage 3.
- Extra potential-free contact for operating display, e.g. incorporation in central building control system.
- Central inclusion in KNX/EIB bus with corresponding bus components possible.

Anti-frost protection

- Guaranteed anti-frost protection ensures that the heat exchanger does not freeze.
- To achieve this, the volumetric flows are regulated depending on outgoing air temperature.
- The frost protection feature switches the supply air fan off when the outgoing air temperature is too low and automatically back on again.
- Heat recovery systems combined with earth heat exchangers or an electric frost protection feature to also ensure perfect operations at low temperatures. In the winter, the earth heat exchanger also guarantees extra heating power and in the summer, extra cooling power.

Details

Characteristic curve	P. 47
Accessory	P. 62
Wiring diagram	www.maico-fans.com
Assembly instruction	www.maico-fans.com
Product data sheet	www.maico-fans.com

Article	Art. No.	Degree of heat provision %	U _{nom} V	f _{nom} Hz	Connection diameter mm	Air flow volume m ³ /h	P _{nom} W	T _{Max} at I _{Max} °C	Filter class	Degree of protection (IP)	Weight kg
WR 300	0095.0078	90	230	50/60	160	300	125/17	50	G4/F7	00	50
WR 400	0095.0079	90	230	50/60	160	400	245/20	50	G4/F7	00	50

Article	Art. No.	Colour	Heat exchanger construction type
WR 300	0095.0078	Sheet steel, powder coated pearl light grey	Cross-counterflow
WR 400	0095.0079	Sheet steel, powder coated pearl light grey	Cross-counterflow

Dimensions [mm]

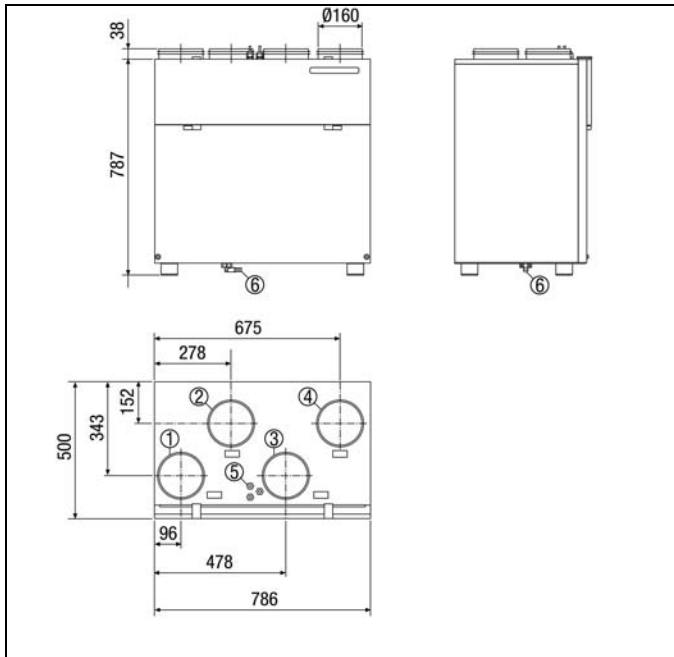

- ① DN 160 outgoing air ② DN 160 supply air ③ DN 160 exhaust air
 ④ DN 160 outside air ⑤ Electrical connection ⑥ Condensation connection

WR 300

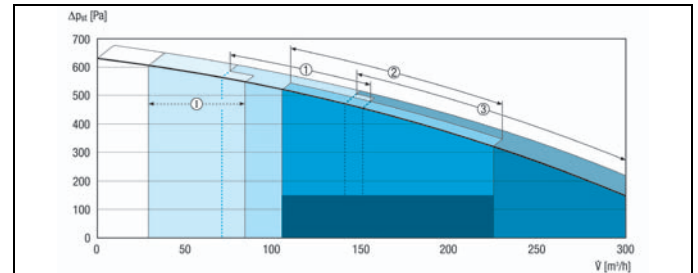

- I Interval operation ① Reduced ventilation ② Nominal ventilation
 ③ Intensive / Party operation

WR 400

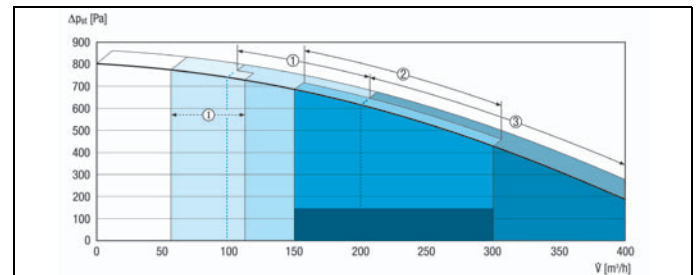

- I Interval operation ① Reduced ventilation ② Nominal ventilation
 ③ Intensive / Party operation

WR 300: Sound power level in octave range (Step 2)

	63 Hz	125 Hz	250 Hz	500 Hz	1 kHz	2 kHz	4 kHz	8 kHz	Total
L _{WA2} [dB(A)]	27	34	38	39	40	33	25	15	45
L _{WA5} [dB(A)]	27	38	33	36	41	33	26	12	44
L _{WA6} [dB(A)]	27	39	32	42	43	35	27	13	47

 Measured at V: 150 m³/h at 100 Pa

WR 400: Sound power level in octave range (Step 2)

	63 Hz	125 Hz	250 Hz	500 Hz	1 kHz	2 kHz	4 kHz	8 kHz	Total
L _{WA2} [dB(A)]	25	37	39	40	43	39	28	14	47
L _{WA5} [dB(A)]	27	39	35	38	43	38	29	16	47
L _{WA6} [dB(A)]	26	41	35	45	45	40	32	17	50

 Measured at V: 200 m³/h at 100 Pa

Recommended accessories	WR 300	WR 400	see
MAICOFlex duct system	MAICO Flex duct system	MAICO Flex duct system	P. 54
Brine earth heat exchanger	EW	EW	P. 58
Stainless steel cowl	LH-V2A 10, LH-V2A 12	LH-V2A 10, LH-V2A 12	www.maico-fans.com
Internal grille	ESG 10/2	ESG 10/2	www.maico-fans.com
Internal grille, adjustable	AZE 100, AZE 100 P	AZE 100, AZE 100 P	P. 62
Roof cowl	DF, DP, BS, RG	DF, DP, BS, RG	www.maico-fans.com
Disk valve, synthetic material	TK 10, TK 12	TK 10, TK 12	P. 62
Stainless steel disk valve	TM-V2A 10, TM-V2A 12	TM-V2A 10, TM-V2A 12	www.maico-fans.com
Disk valve, metal	TFA 10, TFA 12, TFZ 10, TFZ 12	TFA 10, TFA 12, TFZ 10, TFZ 12	www.maico-fans.com
Blower nozzle	WD 10 D, WD 10 W	WD 10 D, WD 10 W	P. 63
Door ventilation grille	MLK 30 white, MLK 45 white	MLK 30 white, MLK 45 white	P. 63
Tubular sound absorber	RSR 10/50, RSR 12/50, RSR 15/50, RSR 16/50	RSR 10/50, RSR 12/50, RSR 15/50, RSR 16/50	www.maico-fans.com
Electrical air heater	ERH 16-2, ERH 16-2 R	ERH 16-2, ERH 16-2 R	www.maico-fans.com
Water air heater	WRH 16-2	WRH 16-2	www.maico-fans.com
Air filter	TFE 16-5, TFE 16-7	TFE 16-5, TFE 16-7	www.maico-fans.com
Air filter, replacement	WSF 300-400, WSG 300-400	WSF 300-400, WSG 300-400	P. 67
Wall bracket	WRK 300-400	WRK 300-400	P. 67
Summer cassette	WRSK 300-400	WRSK 300-400	P. 69
Bypass for heat exchanger	WRBY 300-400	WRBY 300-400	P. 69
Hygrostat	HY 5, HY 5 I	HY 5, HY 5 I	www.maico-fans.com
CO2 sensor	SKD	SKD	www.maico-fans.com
Air flow monitor	LW 9	LW 9	www.maico-fans.com
Room air control	RLS 1 WR, RLS 2 F	RLS 1 WR, RLS 2 F	P. 68



Your advantages

- Quiet operation.
- Quick and easy filter change without any tools.
- Space-saving installation possible in cupboard.

Short description

- Supply and exhaust air unit with heat recovery.
- For apartments up to approx. 120 m².
- Up to 180 m³/h.
- Automatic volumetric flow balancing

Application examples

- Single family-unit house
- Apartment
- Waiting room

Features

- Special energy savings due to the DC motor.
- With sound insulated fans for especially quiet running.
- With automatic volume regulation for constant air quantities.
- Inner coating of heat resistant synthetic material, non-hygrosopic.
- With 2 integrated filters, filter change is possible without tools.
- 4 DN 125 duct connections on the upper side of the unit.

Heat exchanger

- Counterflow plate heat exchanger made of synthetic material (PETG).
- The heat exchanger can be removed easily once the front plate has been unscrewed.
- Separate air flows, separation by means of heat exchanger plates.
- The heat exchanger can be easily cleaned using water.

Heat recovery fan

- 2 centrifugal DC fans, one fan each for supply air and exhaust air.
- Fans with centrifugal impellers curved to the front.
- 3 ventilation steps:
 - 1 = Basic ventilation/Night operation
 - 2 = Normal / Daytime operation
 - 3 = Intensive / Party operation
- Within each ventilation step, the volumetric flow can be adjusted from 50 m³/h up to 180 m³/h in 5 m³/h steps.

Mounting instructions

- With bracket for wall installation, feet for floor installation.
- Mounting on the wall or a pedestal is required to endure access to the condensation connection.
- Housing covers can be unscrewed.
- Connect air channels and condensation drainage prior to commissioning.
- Sound absorbers on the inlet and outlet side are recommended.

Electrical connection

- When delivered, the device is assembled and ready for service.
- Bus can be connected using KNX/EIB bus components.

Condensation drain

- Condensation is drained out from the underside of the unit. Condensation drain (3/4" inner diameter) to connect up to a siphon.

Anti-frost protection

- Guaranteed anti-frost protection ensures that the heat exchanger does not freeze.
- To achieve this, the volumetric flows are regulated depending on outgoing air temperature and pressure loss.
- The frost protection feature switches the supply air fan off when the outgoing air temperature is too low.
- If the outgoing air temperature is higher, the frost protection feature is switched off.
- Heat recovery systems combined with earth heat exchangers or an electric frost protection feature to also ensure perfect operations at low temperatures. In the winter, the earth heat exchanger also guarantees extra heating power and in the summer, extra cooling power.

Details

Characteristic curve	P. 49
Accessory	P. 62
Wiring diagram	www.maico-fans.com
Assembly instruction	www.maico-fans.com
Product data sheet	www.maico-fans.com

Article	Art. No.	Degree of heat provision %	U _{nom} V	Connection diameter mm	Rotating speed 1/min	Air flow volume m ³ /h	I _{Max} A	T _{Max} at I _{Max} °C	Filter class	Degree of protection (IP)	Weight kg
WRG 180 EC	0082.0059	90	230	125	2,070	180	1	50	G4	31	25

Article	Art. No.	Colour	Heat exchanger construction type
WRG 180 EC	0082.0059	Sheet steel, varnished	Pearl white, similar to RAL 1013
			Cross-counterflow

Dimensions [mm]

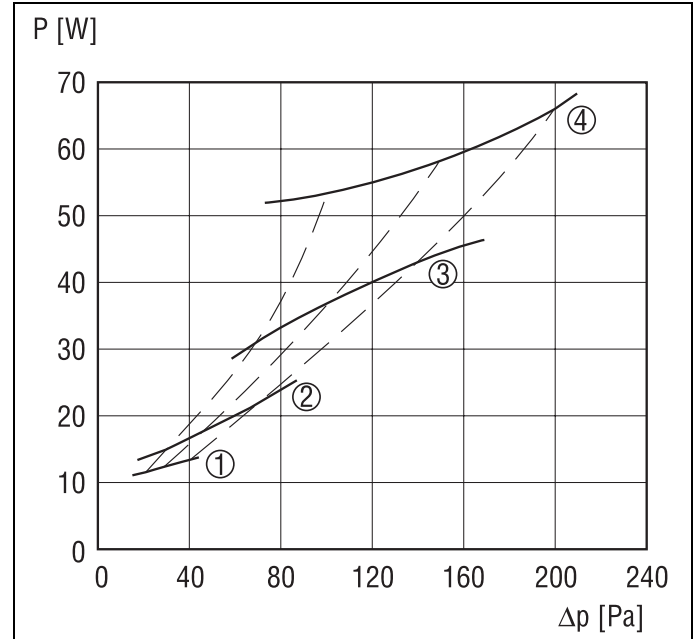
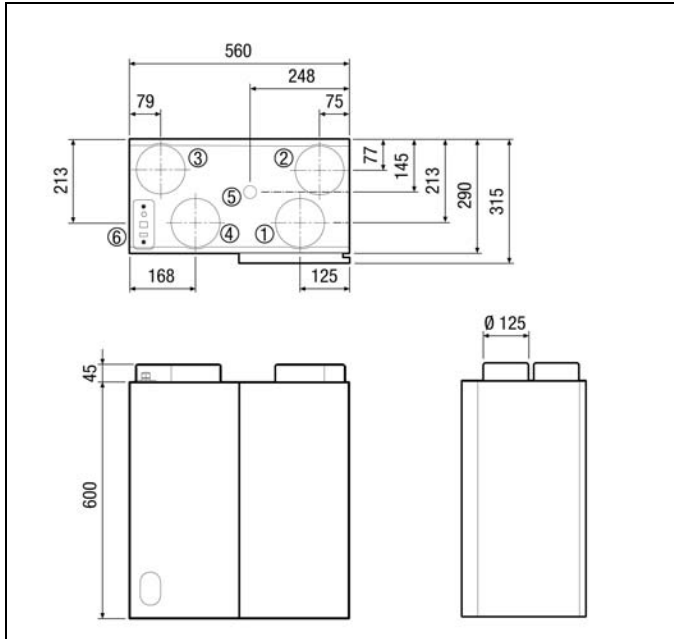

- ① DN 125 exhaust air ② DN 125 outside air ③ DN 125 supply air
 ④ DN 125 outgoing air ⑤ Condensation connection ⑥ Electrical connection

- ① Step 1: 75 m³/h ② Step 2: 100 m³/h ③ Step 3: 150 m³/h ④ Step 4: 180 m³/h

Sound power level in the octave range (level 3)

	Aggregate level
L _{WA2} [dB(A)]	39
L _{WA5} [dB(A)]	37
L _{WA6} [dB(A)]	56

L_{WA2} = housing sound pressure level in dB.
 L_{WA5} = free inlet sound pressure level in dB.
 L_{WA6} = free outlet sound pressure level in dB.

Recommended accessories	WRG 180 EC	see
MAICOFlex duct system	MAICO Flex duct system	P. 54
Brine earth heat exchanger	EW	P. 58
External grille	SG 120	www.maico-fans.com
Stainless steel cowl	LH-V2A 10, LH-V2A 12	www.maico-fans.com
Internal grille	ESG 10/2	www.maico-fans.com
Internal grille, adjustable	AZE 100, AZE 100 P	P. 62
Roof cowl	DF, DP, BS, RG	www.maico-fans.com
Disk valve, synthetic material	TK 10, TK 12	P. 62
Stainless steel disk valve	TM-V2A 10, TM-V2A 12	www.maico-fans.com
Disk valve, metal	TFA 10, TFA 12, TFZ 10, TFZ 12	www.maico-fans.com
Blower nozzle	WD 10 D, WD 10 W	P. 63
Door ventilation grille	MLK 30 white, MLK 45 white	P. 63
Tubular sound absorber	RSR 10/50, RSR 12/50	www.maico-fans.com
Electrical air heater	ERH 12-1	www.maico-fans.com
Water air heater	WRH 12-1	www.maico-fans.com
Air filter	TFE 12-4, TFE 12-5, TFE 12-7	www.maico-fans.com
Air filter, replacement	WRF 180 EC	P. 67
Air flow monitor	LW 9	www.maico-fans.com
Room air control	RLS 2 F	P. 68



Your advantages

- High degree of heat provision saves energy and costs.
- Automatic volumetric flow regulation for constant air quantities.

Short description

- Supply and exhaust air unit with heat recovery.
- For single family-unit houses up to approx. 200 m².
- Up to 300 m³/h.
- Simple adjustment of the volumetric flows.
- Easy filter change.

Application examples

- Low energy house
- Living room
- Waiting room

Features

- Special energy savings due to DC motors having EC technology for constant volumetric flow.
- With sound insulated fans for especially quiet running.
- With automatic volumetric flow regulation for constant air quantities.
- Inner coating of heat resistant synthetic material, non-hygroscopic.
- Easy filter change.
- With two integrated G4 filters, filter change is possible without tools.
- 4 DN 160 duct connections on the upper side of the unit.

Heat exchanger

- Counterflow plate heat exchanger made of synthetic material (PETG).
- The heat exchanger can be removed easily once the front plate has been unscrewed.
- Separate air flows, separation by means of heat exchanger plates.
- The heat exchanger can be easily cleaned using water.

Heat recovery fan

- 2 centrifugal DC fans, one fan each for supply air and exhaust air.
- Fans with centrifugal impellers curved to the front.
- 3 ventilation steps:
 - 1 = Basic ventilation/Night operation
 - 2 = Normal / Daytime operation
 - 3 = Intensive / Party operation
 Factory setting: 100 m³/h / 150 m³/h / 225 m³/h
- Within each ventilation step, the air volume can be adjusted from 50 m³/h up to 300 m³/h in 5 m³/h steps.

Mounting instructions

- With bracket for wall installation, feet for floor installation.
- Mounting on the wall or a pedestal is required to endure access to the condensation connection.
- Housing covers can be unscrewed.
- Connect air channels and condensation drainage prior to commissioning.
- Sound absorbers on the inlet and outlet side are recommended.

Electrical connection

- When delivered, the device is assembled and ready for service.
- Bus can be connected using KNX/EIB bus components.

Condensation drain

- Condensation is drained out at the bottom of the unit. Condensation drainage (3/4" internal thread) for connection to a drain trap.

Anti-frost protection

- Guaranteed anti-frost protection ensures that the heat exchanger does not freeze.
- To achieve this, the volumetric flows are regulated depending on outgoing air temperature and pressure loss.
- The frost protection feature switches the supply air fan off when the outgoing air temperature is too low.
- If the outgoing air temperature is higher, the frost protection feature is switched off.
- Heat recovery systems combined with earth heat exchangers or an electric frost protection feature to also ensure perfect operations at low temperatures. In the winter, the earth heat exchanger also guarantees extra heating power and in the summer, extra cooling power.

Details

Characteristic curve	P. 51
Accessory	P. 62
Wiring diagram	www.maico-fans.com
Assembly instruction	www.maico-fans.com
Product data sheet	www.maico-fans.com

Article	Art. No.	Material	Colour	Heat exchanger construction type
WRG 300 EC	0082.0060	Sheet steel, galvanised	Pearl white, similar to RAL 1013	Cross-counterflow

Dimensions [mm]

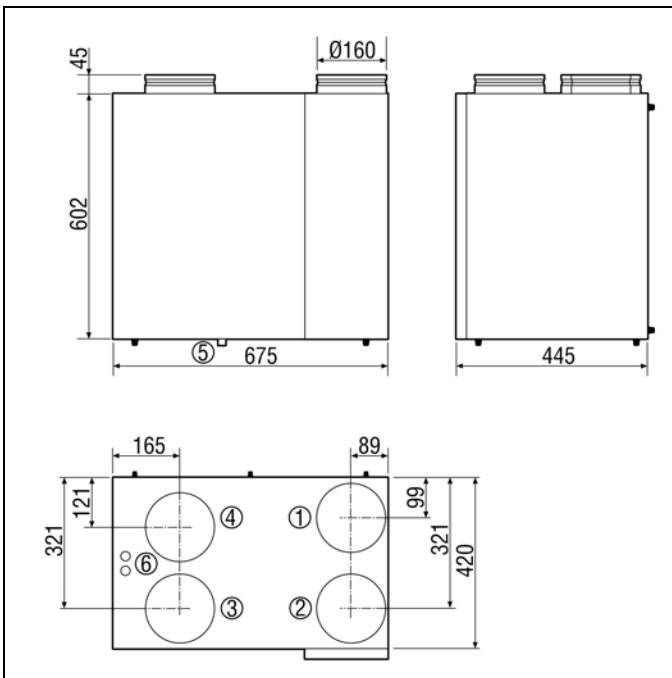

WRG 300 EC

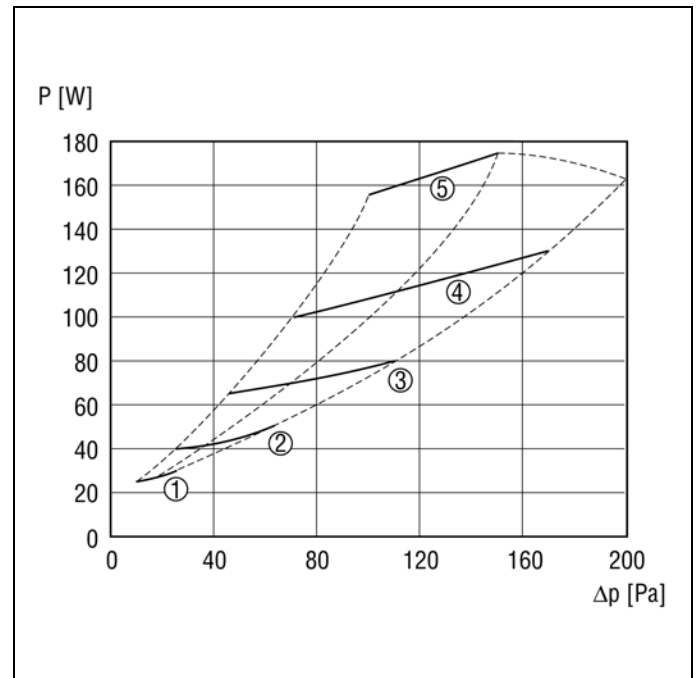

- ① DN 160 outside air ② DN 160 exhaust air ③ DN 160 outgoing air
 ④ DN 160 supply air ⑤ Condensation connection ⑥ Electrical connection

- ① 100 m³/h ② 150 m³/h ③ 200 m³/h ④ 250 m³/h ⑤ 300 m³/h

Sound power level in octave range (Step 3)

	63 Hz	125 Hz	250 Hz	500 Hz	1 kHz	2 kHz	4 kHz	8 kHz	Total
L_{WA2} [dB(A)]	25	33	38	39	41	38	40	33	47
L_{WA5} [dB(A)]	22	33	34	33	33	27	25	26	40
L_{WA6} [dB(A)]	36	48	53	57	60	55	52	47	63

- L_{WA2} = housing sound pressure level in dB.
 L_{WA5} = free inlet sound pressure level in dB.
 L_{WA6} = free outlet sound pressure level in dB.

Recommended accessories	WRG 300 EC	see
MAICOFlex duct system	MAICO Flex duct system	P. 54
Brine earth heat exchanger	EW	P. 58
Stainless steel cowl	LH-V2A 10, LH-V2A 12	www.maico-fans.com
Internal grille	ESG 10/2	www.maico-fans.com
Internal grille, adjustable	AZE 100, AZE 100 P	P. 62
Roof cowl	DF, DP, BS, RG	www.maico-fans.com
Disk valve, synthetic material	TK 10, TK 12	P. 62
Stainless steel disk valve	TM-V2A 10, TM-V2A 12	www.maico-fans.com
Disk valve, metal	TFA 10, TFA 12, TFZ 10, TFZ 12	www.maico-fans.com
Blower nozzle	WD 10 D, WD 10 W	P. 63
Door ventilation grille	MLK 30 white, MLK 45 white	P. 63
Tubular sound absorber	RSR 10/50, RSR 12/50, RSR 15/50, RSR 16/50	www.maico-fans.com
Electrical air heater	ERH 16-2	www.maico-fans.com
Electrical air heater with controller	ERH 16-2 R	www.maico-fans.com
Water air heater	WRH 16-2	www.maico-fans.com
Air filter	TFE 16-5, TFE 16-7	www.maico-fans.com
Air filter, replacement	WRF 300 EC	P. 67
Summer cassette	SK 300 Plus	P. 69
Air quality controller	EAQ 10/1	www.maico-fans.com
Air flow monitor	LW 9	www.maico-fans.com
Room air control	RLS 2 F	P. 68



Your advantages

- High degree of heat provision saves energy and costs.
- Automatic volumetric flow regulation for constant air quantities.

Short description

- Supply and exhaust air unit with heat recovery.
- For single family-unit houses up to approx. 200 m².
- Up to 300 m³/h.
- Simple adjustment of the volumetric flows.
- Easy filter change.

Application examples

- Low energy house
- Single family-unit house
- Apartment
- Living room
- Office
- Waiting room
- Commercial premises

Features

- Special energy savings due to DC motors having a constant volumetric flow.
- With sound insulated fans for especially quiet running.
- With automatic volumetric flow regulation for constant air quantities.
- Inner coating of heat resistant synthetic material, non-hygroscopic.
- Easy filter change.
- With two integrated G4 filters, filter change is possible without tools.
- 4 DN 180 duct connections on the upper side of the unit.

Heat exchanger

- Counterflow plate heat exchanger made of synthetic material (PETG).
- The heat exchanger can be removed easily once the front plate has been unscrewed.
- Separate air flows, separation by means of heat exchanger plates.
- The heat exchanger can be easily cleaned using water.

Heat recovery fan

- 2 centrifugal DC fans, one fan each for supply air and exhaust air.
- Fans with centrifugal impellers curved to the front.
- 3 ventilation steps:
 - 1 = Basic ventilation / Night operation
 - 2 = Normal / Daytime operation
 - 3 = Intensive / Party operation
 Factory setting: 100 m³/h / 200 m³/h / 300 m³/h
- Within each ventilation step, the air volume can be adjusted from 50 m³/h up to 400 m³/h in 5 m³/h steps.

Mounting instructions

- With bracket for wall installation, feet for floor installation.
- Mounting on the wall or a pedestal is required to endure access to the condensation connection.
- Housing covers can be unscrewed.
- Connect air channels and condensation drainage prior to commissioning.
- Sound absorbers on the inlet and outlet side are recommended.

Electrical connection

- When delivered, the device is assembled and ready for service.
- Bus can be connected using KNX/EIB bus components.

Condensation drain

- Condensation is drained out at the bottom of the unit. Condensation drainage (3/4" internal thread) for connection to a drain trap.

Anti-frost protection

- Guaranteed anti-frost protection ensures that the heat exchanger does not freeze.
- To achieve this, the volumetric flows are regulated depending on outgoing air temperature and pressure loss.
- The frost protection feature switches the supply air fan off when the outgoing air temperature is too low.
- If the outgoing air temperature is higher, the frost protection feature is switched off.
- Heat recovery systems combined with earth heat exchangers or an electric frost protection feature to also ensure perfect operations at low temperatures. In the winter, the earth heat exchanger also guarantees extra heating power and in the summer, extra cooling power.

Details

Characteristic curve	P. 53
Accessory	P. 62
Wiring diagram	www.maico-fans.com
Assembly instruction	www.maico-fans.com
Product data sheet	www.maico-fans.com

Article	Art. No.	Material	Colour	Heat exchanger construction type
WRG 400 EC	0082.0061	Sheet steel, galvanised	Pearl white, similar to RAL 1013	Cross-counterflow

Dimensions [mm]

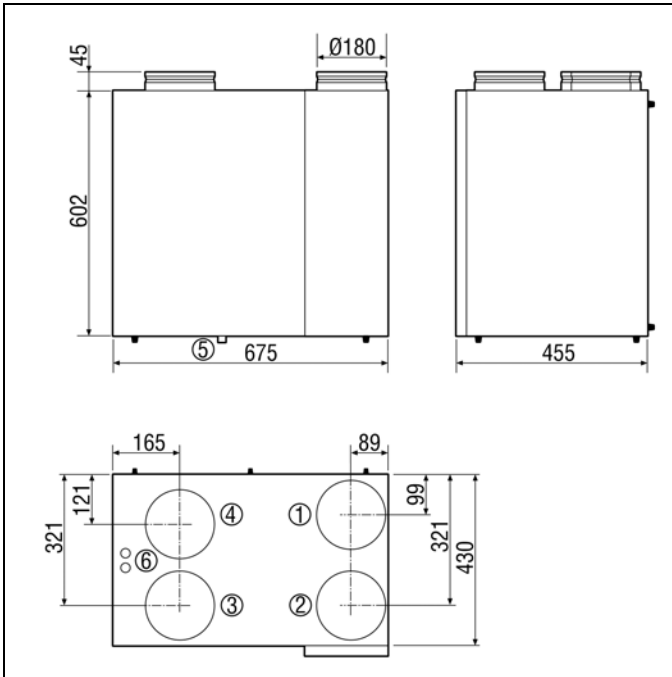

WRG 400 EC

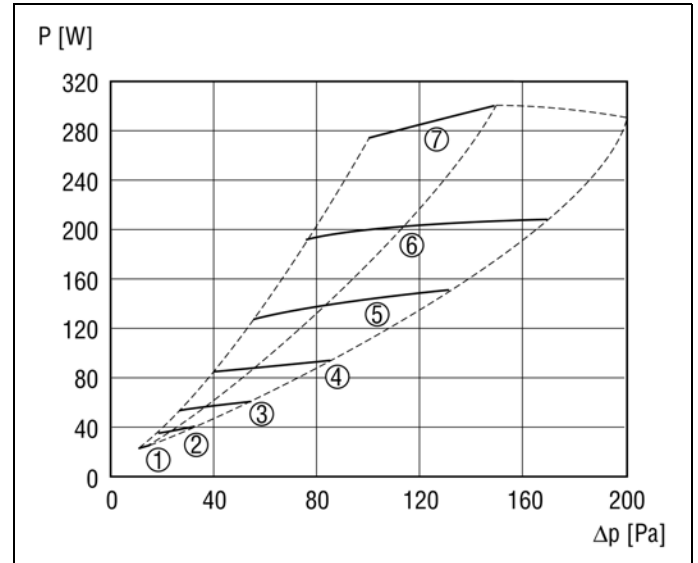

- ① 100 m³/h ② 150 m³/h ③ 200 m³/h ④ 250 m³/h ⑤ 300 m³/h
 ⑥ 350 m³/h ⑦ 400 m³/h

- ① DN 180 outside air ② DN 180 exhaust air ③ DN 180 outgoing air
 ④ DN 180 supply air ⑤ Condensation connection ⑥ Electrical connection

Sound power level in octave range (Step 5)

	63 Hz	125 Hz	250 Hz	500 Hz	1 kHz	2 kHz	4 kHz	8 kHz	Total
L _{WA2} [dB(A)]	31	39	46	46	46	45	51	43	55
L _{WA5} [dB(A)]	27	37	44	44	39	36	31	27	48
L _{WA6} [dB(A)]	40	55	59	64	64	62	59	54	69

- L_{WA2} = housing sound pressure level in dB.
 L_{WA5} = free inlet sound pressure level in dB.
 L_{WA6} = free outlet sound pressure level in dB.

Recommended accessories	WRG 400 EC	see
MAICOFlex duct system	MAICO Flex duct system	P. 54
Brine earth heat exchanger	EW	P. 58
Stainless steel cowl	LH-V2A 10, LH-V2A 12	www.maico-fans.com
Internal grille	ESG 10/2	www.maico-fans.com
Internal grille, adjustable	AZE 100, AZE 100 P	P. 62
Disk valve, synthetic material	TK 10, TK 12	P. 62
Stainless steel disk valve	TM-V2A 10, TM-V2A 12	www.maico-fans.com
Disk valve, metal	TFA 10, TFA 12, TFZ 10, TFZ 12	www.maico-fans.com
Blower nozzle	WD 10 D, WD 10 W	P. 63
Door ventilation grille	MLK 30 white, MLK 45 white	P. 63
Tubular sound absorber	RSR 18, RSR 20, RSR 10/50, RSR 12/50, RSR 18/50, RSR 20/50	www.maico-fans.com
Electrical air heater	ERH 20-2	www.maico-fans.com
Water air heater	WRH 20-2	www.maico-fans.com
Air filter	TFE 20-5, TFE 20-7	www.maico-fans.com
Air filter, replacement	WRF 400 EC	P. 67
Summer cassette	SK 300 Plus	P. 69
Air quality controller	EAQ 10/1	www.maico-fans.com
Air flow monitor	LW 9	www.maico-fans.com
Room air control	RLS 2 F	P. 68

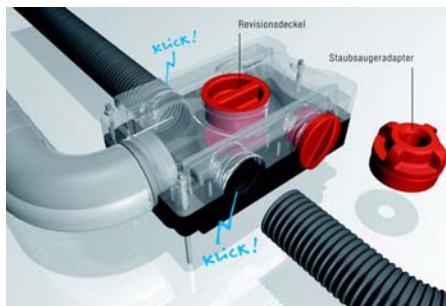

The components of the MAICOFlex duct system

The flexible MAICOFlex duct system is the ideal supplement to the WS, WR and WRG room air systems. It gives you all the components you need from one source:

- Distributor
- Adaptor
- Flexible ducts
- Supply and exhaust air valves

The flexible MAICOFlex duct system is perfect for both new builds and redevelopments.

Your advantages

- Simple and quick installation thanks to the well-proven "click" principle.
- The system can be used for new buildings as well as for renovation.
- All components from one supplier.
- Optimal hygiene thanks to specially designed cleaning kit.

Short description

- Duct system for all room air systems.
- Coordinated components.
- For new buildings and for renovation.

Application examples

- Apartment
- Renovation
- Flat occupying the whole of one floor
- Tenant apartment
- Single family-unit house
- Multiple family unit
- Office

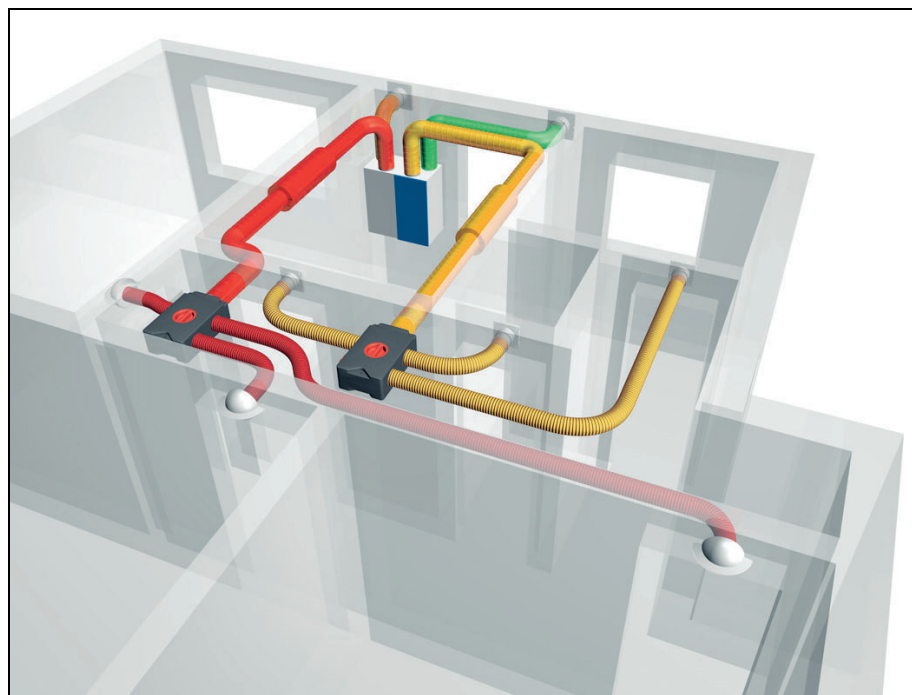

The diagram shows a typical installation situation with all relevant components.

The WRG 180 EC room air system is fitted in the kitchen (e.g. in top cupboard).

Air is exchanged with the outside via 2 core bores, DN 125 folded spiral-seams ducts and the AP 120 shutter and/or the SG 120 protective grille.

DN 125 folded spiral-seams ducts link the WRG 180 EC to the MF-V air distributor. One RSR 12/50 tubular sound absorber, fitted in the unit duct, reduces noise levels in the apartment.

DN 75 or DN 90 flexible steel ducts, fitted with mounting clamps, link the air distributor to the rooms.

The ducts run in the corridor's suspended ceiling. The flexible ducts in the corridor are linked to the rooms via core bores and the adaptors attached in the walls.

In rooms requiring supply air (bedroom, children's room, living room and dining room), the blower nozzles are inserted in the adaptors. The same applies in the rooms with exhaust air (kitchen, bathroom and WC) with the AZE internal grille.

Details

Accessory	P. 55
Wiring diagram	www.maico-fans.com
Assembly instruction	www.maico-fans.com
Product data sheet	www.maico-fans.com

**Air Distributor
MF-V**

- Air distributor with several connections for flexible steel ducts
- Made from sound-proof material With revision opening
- Revision opening either to the side of or on the underside of the distributor
- With pre-drilled holes for installation with threaded rods.
- With revision opening.

Common features

Material	Plastic EPP
Synthetic material definition	PVC-free
Air direction	Ventilation and air extraction

Article	Art. No.	Number of couplings	Nominal size
MF-V63	0059.0970	8	63
MF-V75	0059.0969	4	75
MF-V90	0059.0968	4	90

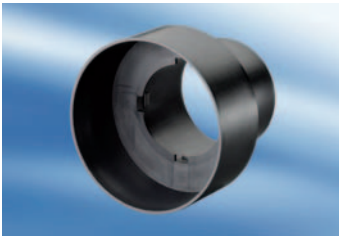
**Valve adaptor
MF-A**

- Adaptor for coupling with perfect fit between flexible steel duct and supply air or exhaust air valve.
- The adaptor is quickly and reliably linked to the MF-F flexible steel duct using the "click principle".

Dimensions [mm]

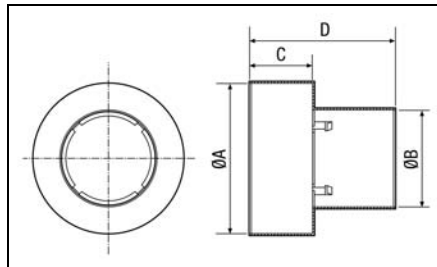
Common features

Material	Polypropylen
Synthetic material definition	PVC-free
Air direction	Ventilation and air extraction

Article	Art. No.	Nominal size mm
MF-A63	0059.0965	63
MF-A75	0059.0964	75
MF-A90	0059.0963	90

Article	A	B	C	D
MF-A63	100	64,5	42	97
MF-A75	100	76,5	42	102
MF-A90	100	92	42	102

**Flexible duct
MF-F**

Article	Art. No.	Max. volumetric flow m³/h	Minimum bend radius mm
MF-F63	0055.0097	20	150
MF-F75	0055.0096	30	150
MF-F90	0055.0095	50	350

Article	External diameter	Internal diameter
MF-F63	63	53,5
MF-F75	75	64
MF-F90	90	77,5

- Particularly flexible ducts.
- Specially developed for ventilation applications
- Simple installation because the duct's flexibility allows it to be moved between the air distributor and supply air or exhaust air valve.
- Length: 50 m
- Material: PE.

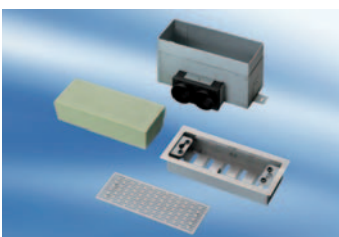
**Floor / wall outlet
MF-FBWA 63**

- Floor and wall outlet for MAICOFlex ventilation system.
- For connecting 2 flexible MF-F ducts.
- Stainless steel air grille with slotted look.

Common features

Nominal size	63 mm
Max. volumetric flow	30 m³/h
Housing material	Sheet steel, Sendzimir galvanised
Grille material	Stainless steel
Air direction	Ventilation
Width x Height x Depth	330 x 290 x 130 mm

Article	Art. No.
MF-FBWA 63	0152.0057

Bracket MF-W

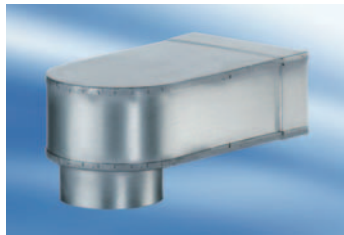

- 90° adaptor for round cross-section (supply air or exhaust air valve) on MF-WE slide-in adaptor.
- Connection couplings with collar size.

Dimensions [mm]

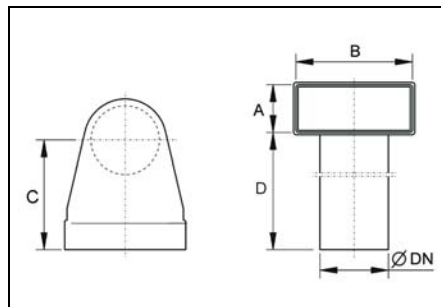

Article	Art. No.	Nominal size
MF-W100 80/150	0018.0494	100
MF-WL100 80/150	0018.0495	100
MF-WL100 80/200	0018.0530	100
MF-WL125 80/200	0018.0531	125
MF-WL125 80/150	0018.0499	125
MF-W150 80/200	0018.0496	150
MF-WL150 80/200	0018.0497	150

! Common features

Material	Sheet steel, galvanised
Air direction	Ventilation and air extraction

Slide-in adaptor MF-WE



- The slide-in adaptor is needed to produce the coupling with perfect fit between the MF-F flexible steel duct and MF-W bracket.
- The MF-F flexible steel duct is quickly and securely linked to the slide-in adaptor using the "click principle".

Dimensions [mm]

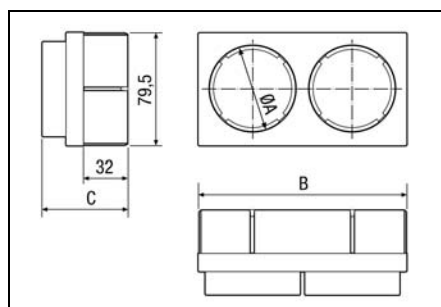

Article	Art. No.	Nominal size mm
MF-WE63	0059.0966	63
MF-WE75	0059.0972	75

! Common features

Material	Polypropylen
Synthetic material definition	PVC-free
Air direction	Ventilation and air extraction

Article	A	B	C
MF-WE63	64,5	149,5	62,5
MF-WE75	76,5	199,5	67,5

Adjustable mounting bracket MF-FB



- Installation aid for routing the MF-FB flexible duct with as small a bend radius as possible without damaging it.
- Also serves as a mounting aid for fixing the duct's position on the wall or ceiling.
- Ensures a secure hold for the flexible duct - additional means of fixing with a cable tie.

Dimensions [mm]

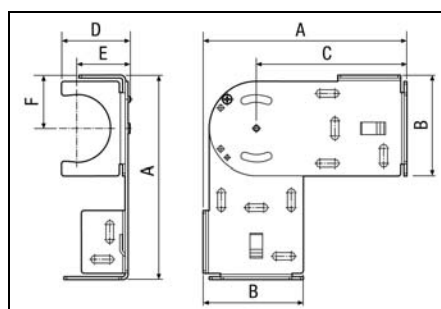

Article	Art. No.	Nominal size mm
MF-FB63	0018.0562	63
MF-FB75	0018.0563	75

! Common features

Material	Sheet steel, galvanised
----------	-------------------------

Article	A	B	C	D	E	F
MF-FB63	163	80	121	55	43	43
MF-FB75	199	91	151	67	50	48

**Mounting clamp
MF-S**

- Mounting clamps for installing the MF-F flexible steel ducts in redevelopments
- Quick installation because the ducts can be fitted without the need for any tools.

Article	Art. No.	Nominal size mm	Width across flats
MF-S63	0018.0471	63	SW 13
MF-S75	0018.0470	75	SW 17
MF-S90	0018.0469	90	SW 17

! Common features

Material	Sheet steel, galvanised
Air direction	Ventilation and air extraction

**Cable clip
MF-K**

- Cable clips for installing the MF-F flexible steel ducts in new builds.

Article	Art. No.
MF-K	0199.0184

! Common features

Material	Kunststoff
Synthetic material definition	PVC-free
Packing unit	100 pieces

**Plug
MF-FST**

- End plug for sealing MF-F flexible steel ducts.
- For protecting against dirt during storage and installation.

Article	Art. No.	Nominal size mm
MF-FST63	0059.0976	63
MF-FST75	0059.0977	75
MF-FST90	0059.0978	90

! Common features

Material	Polyethylen
Packing unit	10 pieces

**Connector
MF-FSM**

- Insertion sleeve for connecting and extending the MF-F flexible steel duct.

Article	Art. No.	Nominal size mm
MF-FSM63	0059.0973	63
MF-FSM75	0059.0974	75
MF-FSM90	0059.0975	90

! Common features

Material	Polyethylen
Synthetic material definition	PVC-free

**Sealing ring
MF-FDR**

- Sealing ring suitable for MAICOFlex MF-F flexible duct.

Article	Art. No.	Nominal size mm
MF-FDR63	0175.0261	63
MF-FDR75	0175.0262	75
MF-FDR90	0175.0263	90

! Common features

Material	EPDM-Gummi
Packing unit	10 pieces

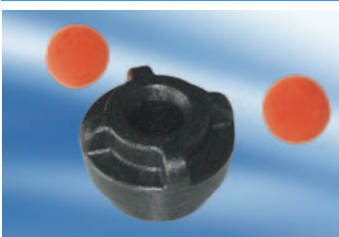
**Cleaning kit
MF-R**

- Cleaning kit for cleaning MF-F flexible steel ducts. A cleaning ball is placed in the duct in the MF-V... air distributor and is then sucked to one of the air outlets using a vacuum cleaner.
- During this process, the cleaning ball removes residual dirt and dust from the flexible steel duct.

- Packing unit: Vacuum cleaner adaptor and 2 cleaning balls.

Article	Art. No.	Nominal size mm
MF-R63	0058.0011	63
MF-R75	0058.0012	75
MF-R90	0058.0013	90



Your advantages

- Cooling of the outside air in summer.
- Pre-heating of the aspired outside air at low outside temperatures.

Short description

- Brine earth heat exchanger for low energy and passive houses.
- Coordinated system of brine air heat exchanger, brine pump controller, pressure ducting and other accessories.
- Recommended to be used in combination with all room air systems with heat recovery.

Application examples

- Low energy and passive houses in combination with room air systems for heat recovery (f.i. aeronom).

System description

- Room air systems for heat recovery run the risk of the heat exchanger icing in winter. This results in condensation if the temperature of the supplied outside air is about 0 °C. This icing greatly reduces the efficiency of the heat exchanger. In extreme cases, the supply air temperature required can no longer be reached.
- To prevent this effect, the outside air has to be heated before it reaches the room air system's heat exchanger. An ideal and effective way of doing this involves preheating with an earth heat exchanger. This makes use of the earth's heat from a depth not encountering frost.
- The simplest solution is to feed the outside air through a duct laid in the ground before it reaches the room air system. This method does however involve risks in terms of air hygiene and any maintenance work which may be required.
- The brine earth heat exchanger from MAICO avoids these risks through the use of high-quality technology. The outside air is not pre-warmed directly in the ground but in a brine-air heat exchanger ahead of the room air system. The brine for the brine-air heat exchanger on the other hand is fed through a closed circuit in the ground. There are no hygiene issues with this solution and access to the outside air duct is possible at all times, as it is not laid in the ground.
- In detail, the MAICO brine earth heat exchanger works as follows:

- A sensor measures the outside air temperature. If this drops below a predefined value limit, the brine earth heat exchanger pump starts up. This pumps a glycol-water mixture through the 2 parallel ducts of the brine circuit, which have been laid in the ground. The ducts are at a depth of between 1.2 and 1.5 metres. This guarantees that the surrounding earth is free of frost. The brine that is being pumped through also takes on this temperature.
- This heat is transferred to the outside air that is being pumped in simultaneously, in a brine-air heat exchanger ahead of the room air system. In this way, the outside air reaches a temperature above freezing. This reliably prevents the icing-up of the downstream air-air heat exchanger in the room air system.
- Furthermore, the same principle is used in summer to cool the outside air down. During the summer months, the ground is cooler than the hot air. Then the outside air transfers its heat to the brine in the brine-air heat exchanger, making itself cooler in the process.

The brine earth heat exchanger from MAICO is made up of the following components:

- EW - S Brine pump controller
- EW - D 100 m PE pressure ducting
- EW - K Brine-air heat exchanger
- EW - G 20 litres of Glykosol N
- EW - Z Accessories

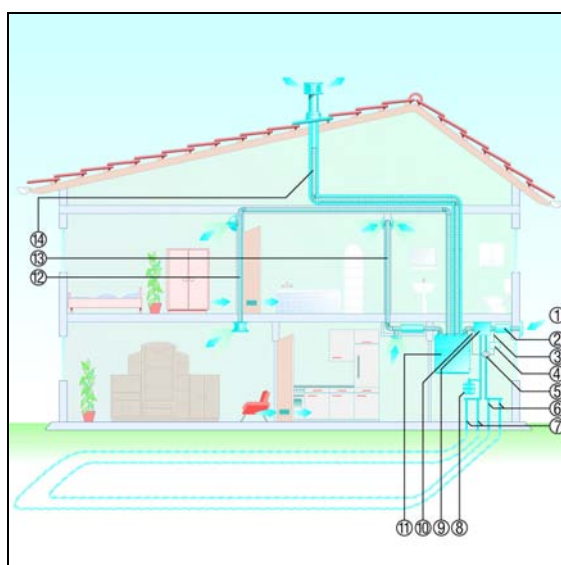

- ① Outside air
- ② Air filter
- ③ Outside air temperature sensor 1, before the brine-air heat exchanger
- ④ EW - S Brine pump controller
- ⑤ Brine pump
- ⑥ Ducting with brine (forward flow)
- ⑦ Ducting with brine (return flow)
- ⑧ Expansion tank membrane
- ⑨ Brine-air heat exchanger
- ⑩ Outside air temperature sensor 2, after the brine-air heat exchanger
- ⑪ Room air system
- ⑫ Supply air
- ⑬ Exhaust air
- ⑭ Outgoing air

Details

Accessory	P. 59
Wiring diagram	www.maico-fans.com
Assembly instruction	www.maico-fans.com
Product data sheet	www.maico-fans.com

Brine pump controller EW-S



- Automatically controls summer and winter operation.
- No seasonal operation required.
- With fault display.
- Switches the pump on at regular intervals, to avoid sticking.
- With predefined factory settings.
- With 2 temperature sensors for outside air temperature before and after the water-air heat exchanger.

Article	Art. No.
EW-S	0157.0203

Brine-air heat exchanger EW-K



- Condensation drainage with 1/2" connection on the side.
- The connection between the register and the PE duct is done by the customer.

Dimensions [mm]

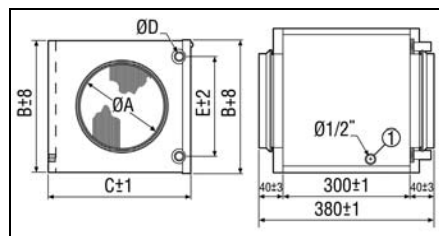

① Condensation drain

- Brine air heat exchanger for heat transfer brine to outside air

Article	Art. No.	Nominal size mm	Brine connection nominal size mm	Max. volumetric flow m³/h
EW-K 160	0192.0404	160	10	165
EW-K 200	0192.0413	200	22	250

Article	A	B	C	D	E
EW-K 160	160	253	313	10	175
EW-K 200	200	328	398	22	250

Glycolol N EW-G



- Heat carrying medium for transferring soil warmth to the outside air.
- 20 litre canister with 100 % Glykolol.
- 25 % glycol-water mixture in the duct circuit.
- Frost-safe down to - 15 °C outside air temperature.
- 1 canister is enough to fill the circuit up completely.

Article	Art. No.
EW-G	0331.0011

Pressure duct EW-D



- PE high-pressure duct, up to 12.5 bar
- 2 x 50 m length

Article	Art. No.	External diameter mm	Wall thickness mm
EW-D	0059.0200	32	2,9

Accessory EW-Z



- Packing unit includes:
- Circulation pump
- Screw fittings
- Pump ball valve
- Boiler battery with safety valve, pressure gauge and vent
- Expansion tank membrane
- Cap valve
- KFE ball valve (tap for filling/emptying a boiler)
- 2 x T-pieces for PE duct

Article	Art. No.
EW-Z	0092.0488



Your advantages

- 14 speed levels for an exact adjustment of the air volume.
- Remote-control contained in scope of delivery.
- Easy to install.
- Flexible installation, can be installed to ceilings, walls and floors.
- Very quiet air extraction for several rooms.
- EC technology saves energy expenses.
- Compact device, can also be installed at limited space.
- Automatic humidity control.

Short description

- Centralised ventilation system with heat recovery.
- For houses and apartments with up to 200 m².
- Output of 360 m³/h at 200 Pa.
- Easy adjustment of air volume using DIP switch.
- Motor and electronics are integrated.

Application examples

- Low energy house
- Single family-unit house
- Apartment
- Living room
- Renovation
- Plant
- Office

Features

- Central air extraction system.
- Easy-to-clean housing.
- The unit is fitted with a quiet-running 3-phase electric motor.
- With 3 intake sockets and an outgoing air socket.
- Motor and electronics are integrated.
- 14 speed levels in total.
- Preset to levels 1, 4 and 8 as standard ("Low", "Normal" and "High").
- The preset speed levels can be easily changed.
- With integrated dampness sensor.

Mounting instructions

- The remote control can be installed in damp rooms - but not in the shower cubicle itself. The remote control must not be sprayed (relative humidity of less than 90 %).
- The ZEG EC unit must be installed in a dry room - it must not come into contact with any spray (relative humidity of less than 90 %).

Electrical connection

- Flexible connecting cable, 1.5 m long.

Dimensions [mm]

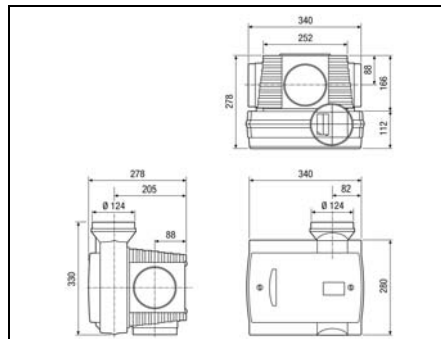

Characteristic curves for ZEG EC

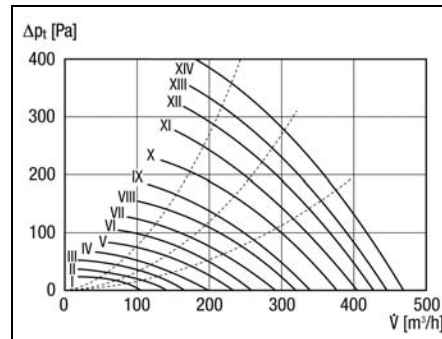

Article	Art. No.	U _{nom} V	Connection diameter mm	Air flow volume m ³ /h	P _{nom} W	I _{Max} A	Degree of protection (IP)	Weight kg
ZEG EC	0086.0205	230	125	375 ¹⁾	81/6	0.6/0.06	20	3.4

¹⁾ System pressure at 175 Pa.

Recommended accessories	ZEG EC	see
Internal grille, adjustable	AZE 100	P. 62
	TK 10, TK 12, TK 15	P. 62
Door ventilation grille	MLK 30 white, MLK 45 white	P. 63
Supply air element	ZE 45 F white	P. 65
Outside air opening	ALD 10, ALD 10 T, ALD 12 S, ALD 12 SVA	P. 64
Storm protection	ALDS 10	P. 65
Roof cowl	DF, DP, BS, RG	www.maico-fans.com
Stainless steel cowl	LH-V2A 10, LH-V2A 12, LH-V2A 15, LH-V2A 16	www.maico-fans.com
Internal grille	ESG 10/2	www.maico-fans.com
Disk valve, synthetic material	TK 10, TK 12,	P. 62
Disk valve	TFA 10, TFA 12, TFZ 10, TFZ 12, TM-V2A 10, TM-VA2 12	www.maico-fans.com
Stainless steel disk valve	TM-V2A 10, TM-V2A 12	www.maico-fans.com
Room air control	ZEG EC-FB	P. 69

Details

Characteristic curve	P. 60
Accessory	P. 62
Wiring diagram	www.maico-fans.com
Assembly instruction	www.maico-fans.com
Product data sheet	www.maico-fans.com

Models

- ZEG 2000: Standard model.
- ZEG 2000 P: Model with higher pressure.

Features

- For simultaneous air extraction of a number of rooms in single family-unit houses or domestic areas.
- High pressure through centrifugal impeller.
- Supply air inlet by means of decentralised outside air openings, e.g. with ZE supply air element.
- 3 ventilation steps can be set.
- Up to 4 intake sockets for exhaust air, to fit DN 125 ducts. The intake sockets can be broken out, as required.
- 1 DN 125 exhaust socket for outgoing air.

Dimensions [mm]

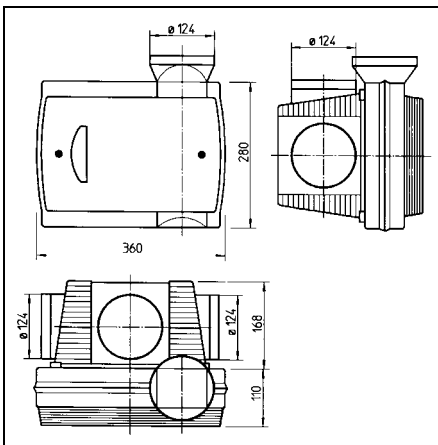

Motor

- Motor designed for continuous operation.
- Thermal overload protection as standard feature.
- ZEG 2000 P: Higher pressure model with a 2-pole motor.

Mounting instructions

- The housing can be fastened in any position to beams, walls or ceilings.

Electrical connection

- When delivered, the device is assembled and ready for service.



Characteristic curves for ZEG 2000, ZEG 2000 P

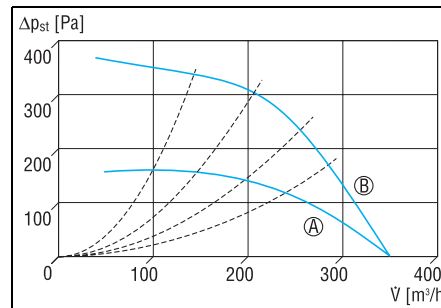

- Ⓐ ZEG 2000
- Ⓑ ZEG 2000 P

Your advantages

- Easy to install
- Flexible installation, can be installed to ceilings, walls and floors
- Very quiet air extraction for several rooms
- Compact device, can also be installed at limited space

Short description

- Centralised air extraction system without heat recovery.
- For apartments and single family-unit houses up to 150 m² living space.
- Ideal for renovation and refurbishment.

Application examples

- Low energy house
- Single family-unit house
- Apartment
- Living room
- Renovation
- Plant
- Office

Article	Art. No.	U _{nom} V	Connection diameter mm	Rotating speed 1/min	Air flow volume m ³ /h	P _{nom} W	I _{Max} A	Degree of protection (IP)	Weight kg
ZEG 2000	0086.0202	230	125	1,180	260	55/24/12	0.24/0.18/0.13	20	3.98
ZEG 2000 P	0086.0203	230	125	1,825	310	92/42/14	0.4/0.3/0.17	20	3.84

Recommended accessories	ZEG 2000	ZEG 2000 P	see
Stainless steel cowl	LH-V2A 10 LH-V2A 12 LH-V2A 15 LH-V2A 16	LH-V2A 10 LH-V2A 12 LH-V2A 15 LH-V2A 16	www.maico-fans.com
Internal grille	ESG 10/2	ESG 10/2	www.maico-fans.com
Internal grille, adjustable	AZE 100	AZE 100	P. 62
Roof outlet	DF	DF	www.maico-fans.com
Roofing tile	DP	DP	www.maico-fans.com
Mounting clamp	BS	BS	www.maico-fans.com
Rain protection grille	RG	RG	www.maico-fans.com
Disk valve, synthetic material	TK 10, TK 12	TK 10, TK 12	P. 62
Stainless steel disk valve	TM-V2A 10, TM-V2A 12	TM-V2A 10, TM-V2A 12	www.maico-fans.com
Disk valve, metal	TFA 10, TFA 12	TFA 10, TFA 12	www.maico-fans.com
Door ventilation grille	MLK 30 white, MLK 45 white	MLK 30 white, MLK 45 white	P. 63
Supply air element	ZE 45 F white	ZE 45 F white	P. 65
Outside air opening	ALD 10, ALD 10 T, ALD 12 S, ALD 12 SVA	ALD 10, ALD 10 T, ALD 12 S, ALD 12 SVA	P. 64
Storm protection	ALDS 10	ALDS 10	P. 65
Room air control	RLS 3	RLS 3	P. 68

Details

Characteristic curve	P. 61
Accessory	P. 62
Wiring diagram	www.maico-fans.com
Assembly instruction	www.maico-fans.com
Product data sheet	www.maico-fans.com

Internal grille, adjustable AZE



- Hygiene grille for ventilation and air extraction.
- Alternative to the disk valve, also for exchange.
- Minimum pressure loss
- Covered filter keeps the duct clean.
- Linear air flow control via internal valve disk.
- Can be set quickly, easily and precisely.
- Setting can be permanently fixed.
- High-quality design for the domestic area.
- Cover can be removed without tools for cleaning.
- Tesa-Moll included in the scope of delivery.
- AZE 100 accessory: ZRF.. spare air filter.
- AZE 100 P accessory: AZP.. spare air filter.

! Common features

Nominal size	100 mm
Material	Synthetic material
Colour	Traffic white, similar to RAL 9016
Max. ambient temperature	60 °C
Air direction	Air extraction / Ventilation

Article	Art. No.	Filter class
AZE 100	0059.0959	G2
AZE 100 P	0059.0962	PPI 20

AZE 100 - Exhaust air pressure loss

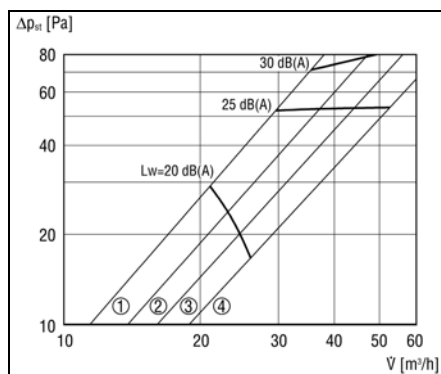

- ① free opening 90°
- ② free opening 135°
- ③ free opening 180°
- ④ free opening 270°

AZE 100 P - Exhaust air pressure loss

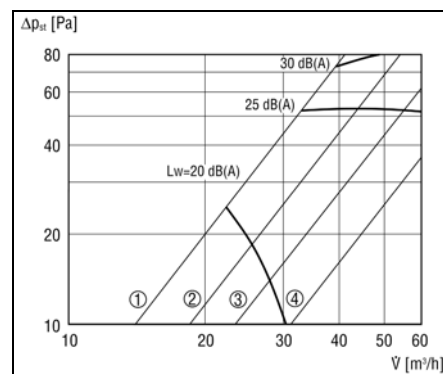

- ① free opening 90°
- ② free opening 135°
- ③ free opening 180°
- ④ free opening 270°

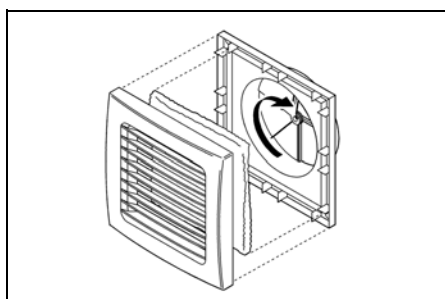

Dimensions [mm]

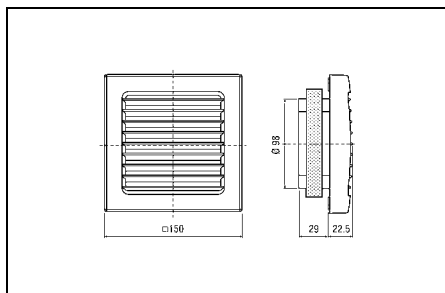

Disk valve, synthetic material TK



- Disk valves for ventilation and air extraction.
- Sealed with a foam ring.
- Linear air flow control via rotatable valve disk.
- Easy installation with mounting ring and clamping springs.

Dimensions [mm]

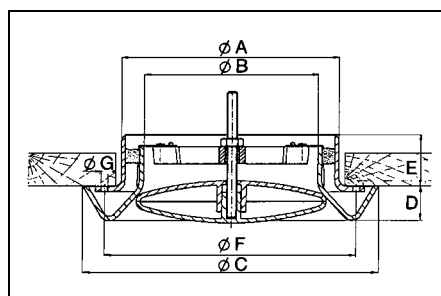

! Common features

Material	Synthetic material, antistatic
Colour	Pure white, similar to RAL 9010
Air direction	Air extraction / Ventilation

Article	Art. No.	Nominal size
TK 10	0151.0192	100
TK 12	0151.0198	125
TK 15	0151.0193	150

Article	A	B	C	D	E	F	G
TK 10	99	80	150	20	31	119	4
TK 12	124	100	170	20	31	145	4
TK 15	149	120	190	20	33	166	4

**Blower nozzle
WD 10 D**

Article	Art. No.
WD 10 D	0151.0291

- Blower nozzles for ventilation.
- For ceiling installation.
- With horizontal air outlet.
- Linear air flow control by means of variable gaps.
- Nominal size: 100 mm
- Range of projection: 5 m

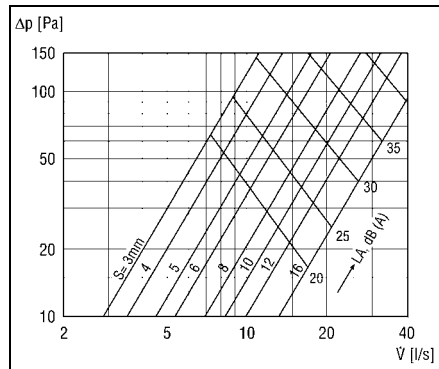
Loss of pressure

s - gap width

Common features

Max. volumetric flow at 10 Pa	70 m ³ /h
Material	Sheet steel, powder coated
Colour	Traffic white, similar to RAL 9016
Air direction	Ventilation

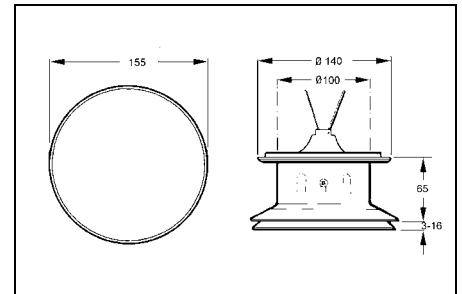
Dimensions [mm]

**Blower nozzle
WD 10 W**

Article	Art. No.
WD 10 W	0151.0290

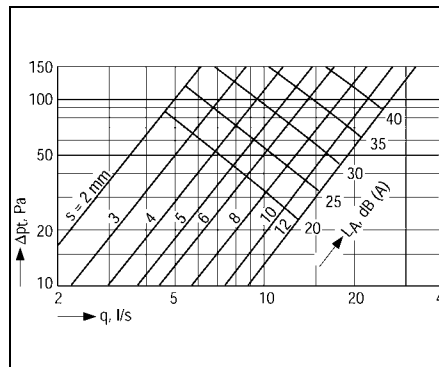
- Blower nozzles for ventilation.
- For wall mounting.
- With horizontal air outlet.
- Linear air flow control by means of variable gaps.
- Nominal size: 100 mm
- Range of projection: 5 m

Loss of pressure

s - gap width

Common features

Max. volumetric flow at 10 Pa	45 m ³ /h
Material	Sheet steel, powder coated
Colour	Traffic white, similar to RAL 9016
Air direction	Ventilation

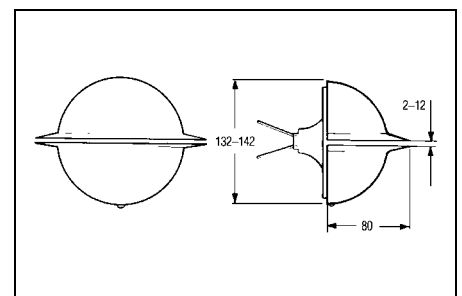
Dimensions [mm]

**Door ventilation grille
MLK**

Article	Art. No.
MLK 30 white	0151.0123
MLK 45 white	0151.0126

- Door ventilation grille for bathroom, WC or kitchen
- Free cross section in accordance with FeuVo 80 (German Heating Directives) and TRGI 86 (German Directives for Gas Installation).
- MLK 30: Door cut-out: 275 x 105 mm, external dimension: 295 x 120 mm.
- MLK 45: Door cut-out: 436 x 76 mm, external dimension: 457 x 92 mm.

Common features

Material	Synthetic material
Synthetic material definition	PVC-free polystyrene
Colour	White
Open cross section	154 cm ²
Air direction	Air extraction / Ventilation
Minimum door leaf thickness	30 mm

Outside air opening ALD 10



Article ALD 10	Art. No. 0152.0054
--------------------------	------------------------------

- Outside air opening for draught-free, decentralised domestic ventilation.
- Linear control of the air flow.
- Packing unit: Internal part, dust or insect filter, wall sleeve up to 500 mm, external grille with fly screen.
- Accessories: ALDS 10 storm protection, ALDF 10 replacement filter.

Common features

Nominal size	100 mm
Max. volumetric flow at 10 Pa	32 m ³ /h
Filter class	G2
Material	Synthetic material
Colour	Pure white, similar to RAL 9010
Rated max. element normal difference in noise level $D_{n,w}$	31 dB
Max. ambient temperature	60 °C
Air direction	Ventilation
Type of shutter	manual

Dimensions [mm]

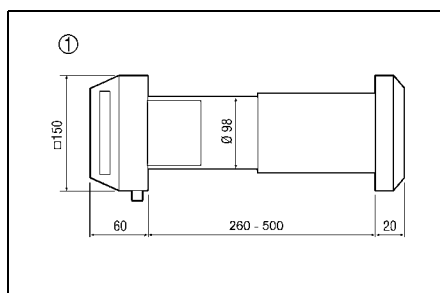

① Inside

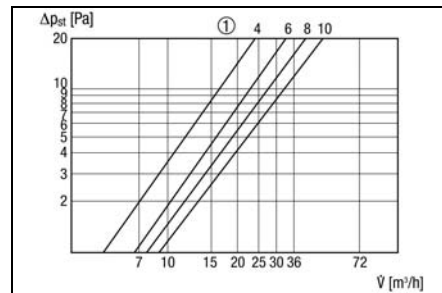

① Valve position in mm

Outside air opening ALD 10 T



Article ALD 10 T	Art. No. 0152.0055
----------------------------	------------------------------

- Airstream-operated outside air opening for draught-free, decentralised domestic ventilation.
- With integrated control thermostat.
- Controls the temperature ranges - 5° C (closed) to + 10° C (open).
- No electrical connection required.
- Packing unit: Temperature-controlled internal part, dust or insect filter, wall sleeve for wall thickness of up to 500 mm, external grille with fly screen.
- Accessories: ALDS 10 storm protection, ALDF 10 T replacement filter.

Common features

Nominal size	100 mm
Max. volumetric flow at 10 Pa	27 m ³ /h
Filter class	G2
Material	Synthetic material
Colour	Pure white, similar to RAL 9010
Rated max. element normal difference in noise level $D_{n,w}$	33 dB
Max. ambient temperature	60 °C
Air direction	Ventilation

Installation instructions

- Recommended layout:
1 ALD 10 T per 30 m² of living space.

Dimensions [mm]

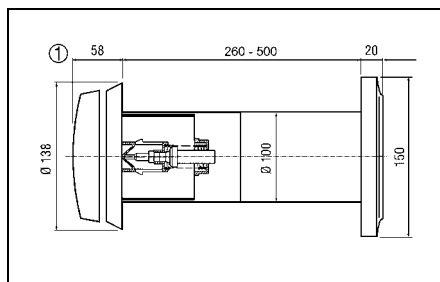

① Inside

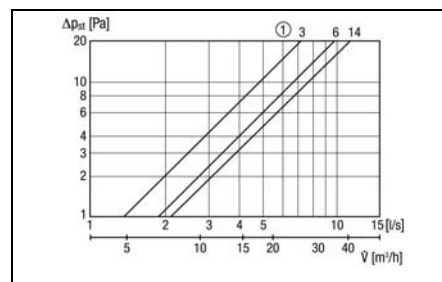

① Valve position in mm

**Storm protection
ALDS 10**

Article	Art. No.
ALDS 10	0152.0056

- Storm protection for air flow regulation with strong or gusty winds.

- Accessories for ALD 10 and ALD 10 T outside air openings.
- Assembly by sliding into the wall sleeve.
- In the case of detached buildings it is recommended that installation be made on the weather side and from the 3rd floor upwards.

Common features	
Nominal size	100 mm
Housing material	Polystyrene
Membrane material	Special silicone

**Outside air opening
ALD 12**

- ALD 12 S packing unit: plastic internal part, dust or insect filter, wall sleeve with storm protection and sound insulation of up to 500 mm, plastic external grille.
- ALD 12 SVA packing unit: plastic internal part, dust or insect filter, wall sleeve with storm protection and sound insulation of up to 500 mm, stainless steel external grille.

Common features	
Max. ambient temperature	60 °C
Air direction	Ventilation
Filter class	G2
Max. volumetric flow	30 m³/h
Rated max. element normal difference in noise level $D_{n,w}$	51 dB

Article	Art. No.	Grille material
ALD 12 S	0152.0052	Synthetic material
ALD 12 SVA	0152.0053	Plastic (internal grille) Stainless steel (external grille)

- Outside air opening for draught-free, decentralised domestic ventilation.
- Linear control of the air flow.
- Accessories: Replacement filter ALDF 12 G2 or ALDF 12 G3.

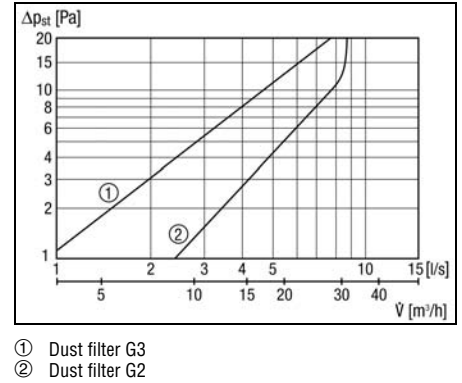
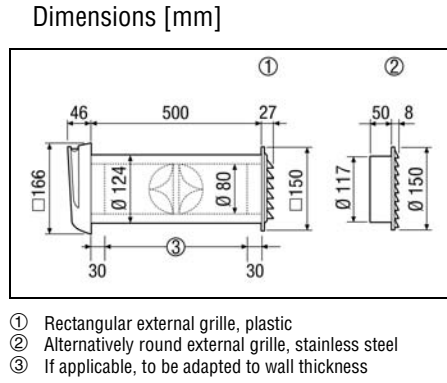

**Supply air element
ZE 45 F**

- The volumetric flow is approx. 22 m with 10 Pa pressure difference and a fully opened valve.³/h.
- Packing unit: Internal part, dust or insect filter, weather protection grille with fly screen.
- Accessories: ZEK 45 F flat channel, ZE 45 GF flat grille, ZEF replacement filter.

Common features	
Filter class	G2
Material	Aluminium
Colour	Traffic white, similar to RAL 9016
Max. ambient temperature	60 °C
Air direction	Ventilation
Type of shutter	manual

- Sound insulated supply air element for decentralised domestic ventilation.
- Linear control of the air flow.
- For installation in window frames.
- Wooden window: Slots are necessary in the window frame.
- Aluminium and PVC windows: A ZEK 45 F air channel is necessary for hollow chamber profiles.

Installation instructions

- Recommended layout:
1 ZE 45 F per 20 m² living space.

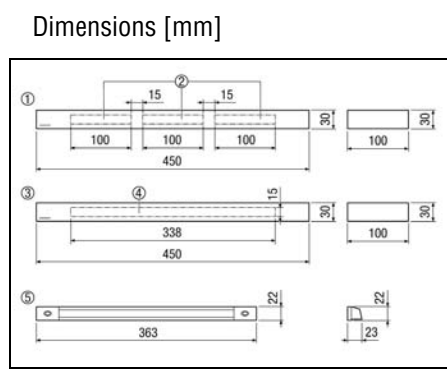

Flat grille ZE GF

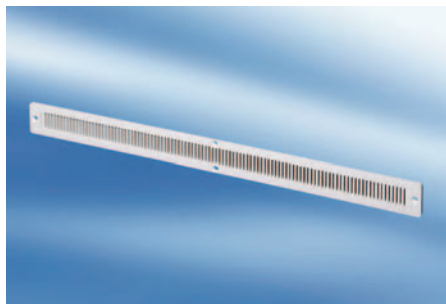

- Flat grille for supply air element ZE 45 F.
- For insect protection.
- Used in blinds mounted on top or in front.

! Common features

Material Synthetic material

Article	Art. No.
ZE 45 GF	0059.0955

Dimensions [mm]

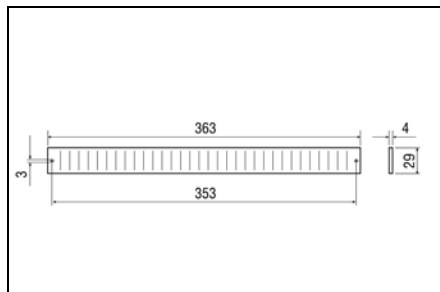

Supply air channel ZEK 45 F



- Supply air channel for installation of supply air element ZE 45 F in PVC windows frames.

! Common features

Material Synthetic material

Article	Art. No.
ZEK 45 F	0152.0050

Accessories for outside air openings ALDF, ZEF

Article	Art. No.	Filter class
ALDF 10	0093.0154	G2
ALDF 10 T	0093.0155	G2
ALDF 12 G2	0093.0152	G2
ALDF 12 G3	0093.0153	G3
ZEF 45 F	0093.0020	G2

- ALDF 10: Replacement air filter for outside air opening ALD 10.
- ALDF 10 T: Replacement air filter for outside air opening ALD 10 T.
- ALDF 12 G2: Replacement filter for ALD 12 S and ALD 12 SVA outside air opening.
- ALDF 12 G3: Replacement filter for ALD 12 S and ALD 12 SVA outside air opening.
- ZEF 45 F: Spare air filter for ZE 45 F.

! Common features

Max. ambient temperature 50 °C
Packing unit 5 pieces

Airstream limiter VSB

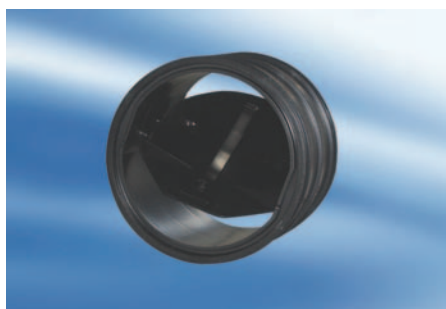

- Simple feeder in DN 100 and/or DN 125 ducts.
- High level of control accuracy
- Maintenance-free.
- Can be operated in any position.
- Quick and easy to set.

! Common features

Material Synthetic material

Article	Art. No.	Nominal size [mm]
VSB 100	0093.0109	100
VSB 125	0093.0110	125

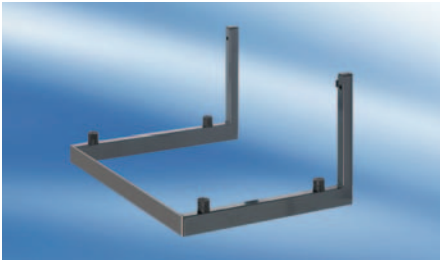
Wall bracket
WSK 150

Article	Art. No.
WSK150	0018.0458

- Wall brackets for mounting the WS 150 room air system.

Dimensions [mm]

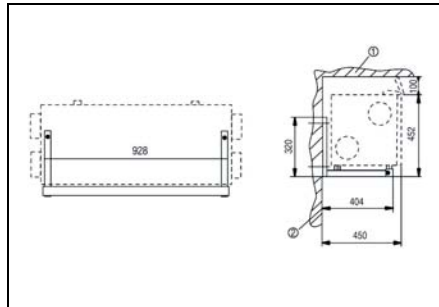

- ① Ceiling
- ② Wall

Common features

Material	Sheet steel, powder coated
Colour	Black

 Wall bracket
WSK 250

Article	Art. No.
WSK 250	0018.0223

- Wall brackets for mounting the WS 250 room air system.

Dimensions [mm]

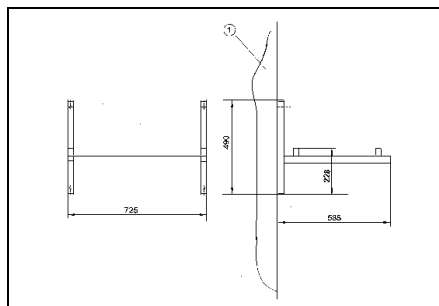

- ① Wall

Common features

Material	Sheet steel, powder coated
Colour	Black

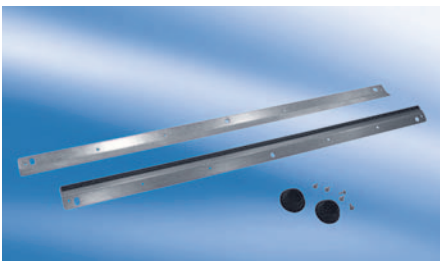
 Wall bracket
WRK 300-400

Article	Art. No.
WRK 300-400	0018.0493

- Wall bracket for mounting the WR 300-400 room air systems.

Common features

Material	Sheet steel, galvanised
Colour	Silver

 Air filter, replacement
WSG, WSF, WRF, ZF

Article	Art. No.	Packing unit	Filter class
WSG 150	0093.0892	2 x G4	G4
WSF 250	0093.0890	2 x G4, 1 x F7	G4 / F7
WSG 250	0093.0891	2 x G4	G4
WSG 600	0093.0886	2 x G4	G4
WSF 300-400	0093.0898	2 x G4, 1 x F7	F7 / G4
WSG 300-400	0093.0897	4 x G4	G4
WRF 180 EC	0093.0060	2 x G4	G4
WRF 300 DC	0093.0023	-	G4
WRF 300 EC	0093.0061	2 x G4	G4
WRF 400 EC	0093.0062	2 x G4	G4
ZF 300	0093.0696	-	G4

- Replacement filters for room air systems.
- WSG 300-400 and WSF 300-400: Replacement filters for WR ... room air systems
- ZF 300: Replacement filter for WRG 300 WP and WRG 300 WPK
- WRF 300 DC: Replacement filter for WRG 300 DC
- WRF ... EC: Replacement filter for WRG EC.

Common features

Max. ambient temperature	50 °C
--------------------------	-------

**Room air control
RLS 1 WR**

- RLS 1 WR control unit is included in the scope of delivery of the WR 300/400 room air system as standard.
- Other operator units can be connected in parallel.
- 4 ventilation levels can be set using buttons.
- With LED-based filter change message.
- With LED-based fault indication.
- Adapter plate for recessed-mounted box for holding control unit included in the scope of delivery of RLS 1 WR.

Article	Art. No.
RLS 1 WR	0157.0809

! Common features

U_{nom}	230 V
Material	Synthetic material

**Room air control
RLS 2 F**

- Control unit for room air systems, f.i. WRG 300 EC, WRG 400 EC, WS 150.
- Manual or automatic circuit as an option.
- Manual circuit of the 3 steps: basic load, normal, full load and off.
- Automatic circuit of the steps basic load and normal load possible by means of a mechanical timer.
- Time programming of the regulating steps in day time programme (24 hours, minimum circuit time 15 minutes) or week time programme (7 days, minimum circuit time 2 hours) possible.
- Switching of the 3 steps is made on low voltage basis (0,1 A at max. 150 VAC).
- With LED display for regulating step full load.
- Time-controlled filter change display, adjustable from 2 to 6 months.
- The filter change is indicated by LED.

Article	Art. No.
RLS 2 F	0157.0806

! Common features

U_{nom}	230 V
Degree of protection (IP)	20
Maximum load (inductive load)	3 A
Material	Synthetic material
Colour	Pure white, similar to RAL 9010
Type of installation	Surface-mounted
Width / Height / Depth	150 mm x 90 mm x 36 mm

**Room air control
RLS 3**

- Three-step room air control for ER 100 D exhaust air fan and ZEG 2000 exhaust air system.
- 3 switch steps: Base load, Normal, Full-load (rotary knob).
- With separate, 2-pole on/off switch (rocker switch).
- Both switches in joint double frame.

Article	Art. No.
RLS 3	0157.0831

! Common features

U_{nom}	230 V
Degree of protection (IP)	30
Maximum load	10 A
Material	Synthetic material
Type of installation	Recessed-mounted
Width / Height / Depth	150 mm x 80 mm x 32 mm

Room air control
ZEG EC-FB

Article	Art. No.
ZEG EC-FB	0157.0411

- Additional wireless remote control for ZEG EC.
- The remote control can be installed in damp rooms - but not in the shower cubicle itself.
- The remote control must not be sprayed (relative humidity of less than 90 %).

 Common features

Battery	Type 3 V CR 2025 V
Material	Synthetic material
Width / Height / Depth	82 mm x 82 mm x 18 mm

 Summer cassette / bypass
SK, WRSK, WRBY

Article	Art. No.	Suitable for products
SK 150	0095.0151	WS 150
SK 300 Plus	0180.0924	WRG 300 EC, WRG 400 EC
WRSK 300-400	0095.0152	WR 300, WR 400
WRBY 300-400	0093.0899	WR 300, WR 400

- SK 150, SK 300 Plus, WRSK 300-400: Summer cassette for the supply of fresh outside air with heat exchange for summer operation.
- WRBY 300-400: bypass for heat exchanger.

Flat channel

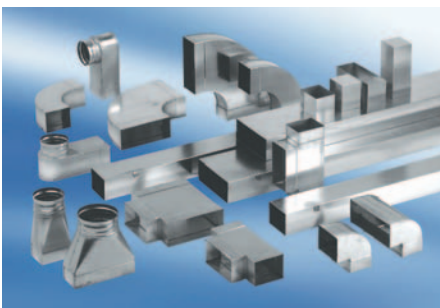

- Flat channel system for controlled domestic ventilation.
- Quick and easy installation.
- Extensive range, e.g.:
 - Channel pieces
 - 45° and 90° elbows
 - Intermediate pieces
 - Branches
 - Sound absorber
 - Shutters
- For more detailed information, refer to the price list and www.maico-fans.com.

 Common features

Material	Sheet steel, Sendzimir galvanised
----------	--------------------------------------

 Folded spiral-seams duct
WFR

- Duct system for controlled domestic ventilation.
- Extensive range, e.g.:
- Ducts, 15°, 30°, 45°, 60° and 90° elbows, reducers, crosspieces, sound absorbers
- For more detailed information, refer to the price list and www.maico-fans.com.

 Common features

Material	Sheet steel
Max. ambient temperature	60 °C
Nennweite:	80 100 125 150 160 180 200

A

Accessibility	15
Accessories	38, 62 - 69
Air channels	46, 48, 50, 52
Air circulation	7, 24
Air distributor	8, 28, 30, 35, 36, 37
Air ducts	5, 7, 10, 14, 28, 35
Air exchange	3, 4, 6, 11, 12, 13, 39
Air exchange rate	3, 4, 6
Air filter	3, 5
Air flow	4, 10, 13, 21, 34
Air flow meter	(see Vane impeller anemometer)
Air heat exchanger	21, 22
Air humidity	60
Air opening	4, 6, 14, 15, 19
Air speeds	6
Air valves	6, 10, 19, 28, 31, 54
Air volume	4, 13
Air-ventilated fireplace	24
Appliance sound	14

B

Basic ventilation	7, 44, 48, 50, 52
Bend radiuses	16, 18, 21
Brine earth heat exchanger	2, 15, 20, 22, 58
Brine-air heat exchanger	58, 59
Building complex	35
Building shell	10, 11, 28

C

Calculation bases	10
Ceiling	4, 6, 8, 14, 16, 18, 19, 28, 29, 32, 54, 61
Central unit	6, 14, 15, 18, 30, 32, 33, 34, 35, 38, 42, 44
Channel sound absorber	14
Clamp	57
Cleaning	6, 14, 35, 36, 37
Cleaning set	14, 35
Coanda effect	19
Cold air	17, 24, 38
Collector (see Geothermal collector)	21
Collector layout plan	23
Combustible air	24
Commissioning	5, 21, 34
Concrete ceiling	8, 16
Condensation	10, 15, 16, 17, 22, 28, 31, 33, 34
Condensation drain	22, 40, 41, 42, 44, 46, 48, 50, 52
Cooling	16, 20, 42, 44, 46, 48, 50, 52

D

Damp room	15, 60
Design	5, 6, 9, 10, 11, 13, 20
Detached house	4, 6, 25
DIBt approval	24, 42
Differential pressure controller	24
Directive	(see Standards)
Disk valve	4, 6, 62
Distributor	8, 14, 18, 21, 28, 30, 32, 33, 35, 36, 37, 54, 55
Door ventilation grille	6, 63
Draughts	6, 9
Duct cross-sections	6
Duct sound absorber	28
Ducting	7, 14, 16, 28, 58
Dynamic pressure	12

E

Exhaust air	3, 4, 6, 7, 8, 10, 16, 19, 24
Exhaust air duct	7, 10, 14, 28
Exhaust air valve	6, 19, 28, 33, 54
Exhaust air volumetric flow	9, 10, 11
Exhaust air zone	10
Exterior grille	31, 33, 36, 37
Extractor hood	24

F

False ceiling	8, 9, 16, 18
Fan speed	34
Filter	5, 35, 50
Fire protection	6, 7, 14, 34
Fireplace	24
Flexible steel duct	8, 9, 14, 16, 18, 28, 29, 30, 32, 33, 54
Flow noise	14
Flow speed	12, 14, 16, 17
F-marking	(see DIBt approval)
Folded spiral-seams duct	69
Footfall sound absorption	14
Formula collection	12
Fresh air supply	6, 7
Fresh air supply	24

G

Gap	6, 17
Geothermal collector	21

H

Heat extraction	20
Heat insulatio	17, 40, 42
Heat load	5
Heat recovery	2, 3, 4, 5, 6, 7, 38, 40, 42, 44, 46, 50, 52, 58, 60
Hydraulic diameter	12

I

Installation	17, 21, 28, 29, 32
Installation depth	20
Installation instructions	6, 15, 21, 28
Installation scenario	14

L

Layout plan	21, 23
-------------	--------

M

MAICOFlex-duc	28, 35, 54
Maintenance	5, 34, 35, 58
Manometer	21, 22
Measuring device	34
Mould	4, 9
Multi-residency building	6

N

Negative pressure	24
Non-air-ventilated fireplace	24

O

Operating pressure	21
Operating unit	10
Outgoing air	4, 9, 10, 14, 15, 28, 31, 33
Outgoing air duct	28
Outgoing air grille	15
Outgoing air opening	14, 15
Outside air	3, 4, 6, 15, 22, 28, 31, 33
Outside air grille	15
Outside air intake	15
Outside air openin	9, 10, 15, 61, 64
Outside air rate	4
Outside air volumetric flow	10, 11, 13, 24

P

Pitch	20, 21
Planning procedure	9, 10
Plug-in adapter	29
Precast ceiling	29
Pressure loss	9, 12, 16, 18, 21, 48, 50, 52
Pressure monitor	21

R

Recirculated air	24
Renovation	2, 3, 11, 18, 32
Resistance coefficient	12
Roof break-through	31, 33
Room air control	38, 39, 68, 69
Room air quality	4, 10

S

Safety device	24
Safety instructions	35
Sealing ring	29, 57
Service opening	16, 28
Setup	34
Siphon	22, 30, 32, 35
Smoke protection	14
Soil temperature	20
Sound insulation	5, 6, 10, 14, 28
Sound transmission	14
Specific geothermal output	20
Specific heat capacity	12, 20
Standards	5, 10, 11
State building code	5
Structural statics	6, 8
Supply air	3, 4, 6, 10, 12, 19, 28, 35

T

Telephony sound	10, 14
Temperature difference	12
Temperature level	20
Temperature measurement	24
Thermal conductivity	20

V

Vane impeller anemometer	34
Ventilation ducts	34, 35
Ventilation methods	7
Ventilation system	2, 3, 5, 6, 7, 9, 10, 11, 13, 20, 24, 31, 33
Volumetric flow	4, 9, 10, 11, 12, 13, 15, 17, 21, 24



MAICO

VENTILATOREN

Maico Elektroapparate-Fabrik GmbH

Steinbeisstraße 20
78056 Villingen-Schwenningen
Germany

Phone numbers:

Sales: +49 7720 694 359

Order processing: +49 7720 694 372

Techn. Advice: +49 7720 694 392

Fax: +49 7720 694 177

www.maico-fans.com

sales@maico.de





MAICO

VENTILATOREN

Maico Elektroapparate-Fabrik GmbH

Steinbeisstraße 20
78056 Villingen-Schwenningen
Germany

Phone numbers:

Sales: +49 7720 694 359

Order processing: +49 7720 694 372

Techn. Advice: +49 7720 694 392

Fax: +49 7720 694 177

www.maico-fans.com

sales@maico.de

