

Assembly and Operating Manual

ECR...EC, Compact Supply air unit

ECR 12-2 EC

ECR 16-2 EC

ECR 20-2 EC

ECR 25-2 EC

ECR 31-2 EC

English

The data specified above only serve to describe the product. No statements concerning a certain condition or suitability for a certain application can be derived from our information. The information given does not release the user from the obligation of own judgment and verification. It must be remembered that our products are subject to a natural process of wear and aging.

This document, as well as the data, specifications and other information set forth in it, are the exclusive property of **Mai-co**. It may not be reproduced or given to third parties without its consent.

The picture on the cover shows an example configuration. The product supplied may therefore differ from the illustration.

The original manual has been produced in the German language.

Information updated: print 16.01.2023
We reserve the right to make changes

Assembly and Operating Manual

Contents

1. Important information	4
1.1. Rules and regulations	4
1.2. Guarantee and liability	4
2. General safety instructions	4
2.1. Intended use	4
2.2. Improper use	5
2.3. Personnel qualifications	5
2.4. Safety instructions in this manual	5
2.5. Adhere to the following instructions	6
2.6. Safety labels on the product	7
3. Delivery contents	7
4. Product and Performance description	8
4.1. Device description	8
5. Transport and storage	9
6. Assembly	9
6.1. Permitted installation positions	10
6.2. Operating limits	10
7. Electrical connection	10
7.1. Overcurrent protection	11
8. Commissioning	12
9. Operation	13
9.1. Control unit	13
9.2. Operation of the menu	19
9.3. Additional functions	28
10. Maintenance and repair	28
10.1. Important notes	28
10.2. Cleaning and care	29
10.3. Maintenance	29
11. Modbus communication interface	30
11.1. Wiring diagram	30
11.2. Interface information	31
11.3. Functions implemented	31
11.4. Parameter table	31
12. Expansion and reconfiguration	34
13. Dismantling and disposal	34
13.1. Disassembling the product	34
13.2. Disposal	34
11.5. Current value table	34
14. Troubleshooting	35
14.1. Low-current fuses	35
14.2. Fault diagnosis chart	35
14.3. Possible operating faults	36
15. Technical data	37
16. Wiring diagrams	38

1. Important information

This manual contains important information on the safe and appropriate assembly, transport, commissioning, operation, maintenance, disassembly and simple troubleshooting of the product.

The product has been manufactured according to the accepted rules of current technology. There is, however, still a danger of personal injury or damage to equipment if the following general safety instructions and the warnings before the steps contained in these instructions are not complied with.

- **Read these instructions completely and thoroughly before working with the product.**
- **Keep these instructions in a location where they are accessible to all users at all times.**
- **Always include the operating instructions when you pass the product on to third parties.**



1.1. Rules and regulations

Also observe the generally applicable, legal or otherwise binding regulations of the European or national legislation and the rules for the prevention of accidents and for environmental protection applicable in your country.

1.2. Guarantee and liability

Maico products are made to the highest technical standards in accordance with the generally recognized rules of the profession. They are subject to constant quality control and meet the relevant requirements when delivered. Because the products are being constantly developed, we reserve the right to make changes to the products at any time and without prior announcement. We do not accept any liability for the correctness or completeness of this installation and operating manual.

The warranty only applies to the delivered configuration. The warranty will not apply if the product is incorrectly assembled or handled or not used as intended.



2. General safety instructions

Planners, plant engineers and operators are responsible for ensuring that the product is installed and operated correctly.

- Exclusively use **Maico** Ventilatoren in good technical order and condition.
- Check the product for visible defects, for example cracks in the housing or missing rivet, screws and covers.
- Only use the product within the performance range provided in the technical data.
- Protection against contact and being sucked in and safety distances should be provided in accordance with DIN EN ISO 13857.
- Generally prescribed electrical and mechanical protection devices are to be provided by the client.
- Safety components must not be bypassed or put out of operation.
- The product may be operated by personnel with limited physical, sensory or mental capacities only if they are supervised or have been instructed by responsible personnel.
- Children must be kept away from the product.

2.1. Intended use

The **Maico** fan is a component in terms of the machine directive 2006/42/EC (partly completed machinery). The product is a not ready-for-use machine in terms of the machine directive. It is intended exclusively for installation in a machine or in ventilation equipment and installations or for combination with other components to form a machinery or installation. The product may be commissioned only if its integrated in the machinery/system for which it is designed and the machinery/system fully complies with the EC machinery directive.

Observe the operating conditions and performance limits specified in the technical data.

Maico ventilation products can be used to provide:

- Clean, dry air (no condensation) and non-aggressive gases with a maximum density of 1.3 kg/m³.
- The medium and room temperatures and the humidity range given in the technical data and on the rating plate.



Intended use includes having read and understood these instructions, especially chapter 2 "General safety instructions".

2.2. Improper use

Any use of the product other than described in chapter "Intended use" is considered as improper. Also note the following points, which are improper and dangerous:

- Delivery of explosive and flammable media or operation in potentially explosive atmospheres.
- Delivery of aggressive and abrasive media.
- Delivery of media containing dust or grease.
- Installation outside without any protection against the weather.
- Installation in wet areas.
- Operation without the duct system.
- Operation with closed air connections.

2.3. Personnel qualifications

Assembly, commissioning and operation, disassembly and service (including maintenance and repair) require basic mechanical and electrical knowledge, as well as knowledge of the appropriate technical terms.

In order to ensure operating safety, these activities may therefore only be carried out by qualified technical personnel or a person under the direction and supervision of qualified personnel. Qualified personnel are those who can recognize possible hazards and institute the appropriate safety measures due to their professional training, knowledge, and experience, as well as their understanding of the relevant conditions pertaining to the work to be done. Qualified personnel must observe the rules relevant to the subject area.

2.4. Safety instructions in this manual

In this manual, there are safety instructions before the steps whenever there is a danger of personal injury or damage to the equipment. The measures described to avoid these hazards must be observed.

Safety instructions are set out as follows:

- Safety sign (warning triangle)** - Draws attention to the risk
- **Type of risk** - Identifies the type or source of the hazard.
 - » **Consequences** - Describes what occurs when the safety instructions are not complied with.
 - **Precautions** - States how the hazard can be avoided.



Safety sign (warning triangle)	Denotation
	General warning! Indicates possible hazardous situations. Failure to observe the warnings may result in personal injury and / or damage to property.
	Electricity warning (hazardous voltage)! Indicates possible hazards due to electricity. Failure to observe the warnings may result in death, injury and/or damage to property.
	Hot surface warning! Indicates possible hazards due to high surface temperatures. Failure to observe the warnings may result in personal injury and/or damage to property.
	Crushing of fingers warning! Indicates possible hazards due to moving and rotating parts. Failure to observe the warnings may result in personal injury.
	Overhead load warning! Indicates possible hazards due to overhead loads. Failure to observe the warnings may result in death, injury and/or damage to property.
	Important instructions follow! Instructions for safe, optimum use of the product.



2.5. Adhere to the following instructions

2.5.1. General instructions

- Observe the provisions for accident prevention and environmental protection for the country where the product is used and at the workplace.
- Persons who assemble, operate, disassemble or maintain **Maico** products must not consume any alcohol, drugs or pharmaceuticals that may affect their ability to respond.
- Responsibilities for the operation, maintenance and regulation of the product should be clearly determined and observed so that there can be no unclear areas of responsibility with regard to safety.
- Never overload the product. Never use it as a handle or step. Do not place anything on it.
- The warranty only applies to the delivered configuration.
- The warranty will not apply if the product is incorrectly assembled or handled or not used as intended.

2.5.2. During installation

- Disconnect all of the product's poles from the mains before installing the product or connecting or removing plugs. Make sure that the product cannot be switched back on again.
- Lay cables and lines so that they cannot be damaged and no one can trip over them.
- Before commissioning, make sure that all gaskets and seals in the plug-in connections are correctly fitted and undamaged in order to prevent fluids and foreign matter getting into the product.
- Information signs must not be changed or removed.

2.5.3. During commissioning

- Make sure that all electrical connections are either used or covered. Commission the product only if it is installed completely.

2.5.4. During operation

- Only authorized personnel is allowed to operate the setting mechanisms of the components or parts, under the provisoion that the system is used as intended.
- In an emergency, or if there is a fault, or other irregularities, switch the equipment off and make sure it cannot be switched back on again.
- The technical data given on the rating plate must not be exceeded.

2.5.5. During cleaning

- Never use solvents or aggressive detergents. Only clean the product using a slightly damp, lint-free cloth. Only use water to do this and, if necessary, a mild detergent.
- Do not use a high-pressure cleaner for cleaning.
- After cleaning, make sure that the product is working correctly again.

2.5.6. During maintenance and repair

- If operated correctly, **Maico** products only require a minimum amount of maintenance. Please follow all of the instructions given in section 10 in this respect.
- Make sure that no connections or components are loosened unless the device is disconnected from the mains. Make sure that the equipment cannot be switched back on again.
- Individual components must not be interchanged. For example, the components intended for one product may not be used for other products.

2.5.7. Disposal

- Dispose the product in accordance with the currently applicable national regulations in your country.

2.6. Safety labels on the product

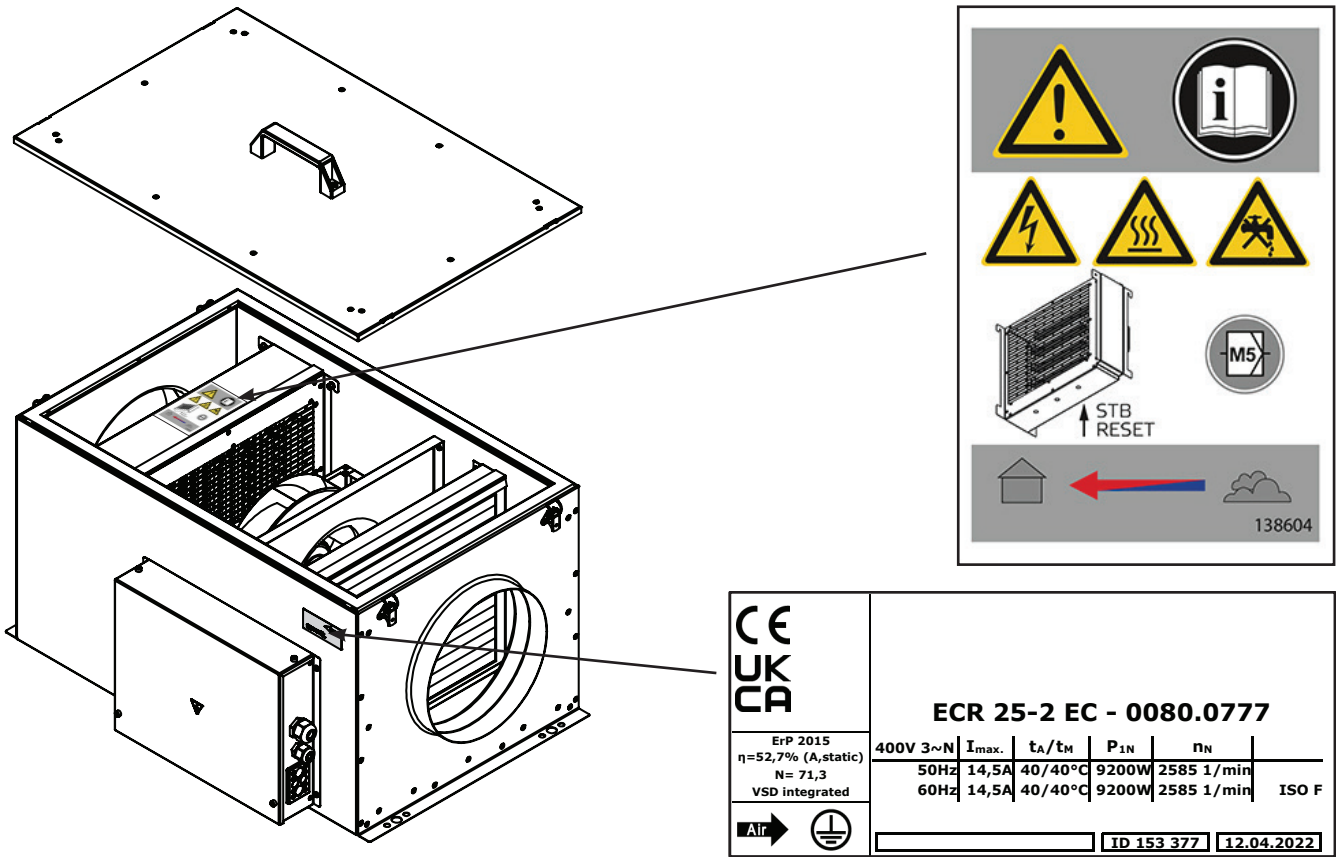

CE UK CA	ECR 25-2 EC - 0080.0777				
	ErP 2015 $\eta=52,7\%$ (A,static) N= 71,3 VSD integrated	400V 3~N	I_{max.}	t_A/t_M	P_{1N}
	50Hz	14,5A	40/40°C	9200W	2585 1/min
	60Hz	14,5A	40/40°C	9200W	2585 1/min
					ISO F
					ID 153 377 12.04.2022

Rating plate example ECR 25-2 EC

Fig. 1:
Safety labels on the product

• General warning

- » Failure to observe the warnings may result in personal injury and / or damage to property.
- Unauthorized repairs may cause personal injury and / or damage to property, in which case the manufacturer's guarantee or warranty will not apply.

• Caution! Burning hazard.

- » Failure to observe the hazard may result in personal injury and/or damage to property.
- Do not touch the surface until the motor and heater have cooled.

• Electricity warning (hazardous voltage)

- » Failure to observe the hazard may result in death, injury or damage to property.
- Before performing any work on conductive parts, always disconnect the unit completely from the electricity supply and make sure that it cannot be switched back on again.

• Never clean the internal space with flowing water or a high-pressure cleaner. Do not use aggressive or easily flammable products for cleaning (impellers/housing).

- Only use mild suds. The impeller should be cleaned with a cloth or brush.

Read the operating manual before commissioning the product.

Air filter (Z-Line) Filter class M5

3. Delivery contents

- Included in delivery depending on model type:
- 1 x FFH compact supply air unit
 - 1 x remote control with control cable
 - 1 x installation and operating manual

4. Product and Performance description

The FFH compact supply air unit is a complete, ready-to-use supply air unit with Z-Line air filter, fan, electric heater and integrated control. The unit has a remote control for controlling and setting up the operating parameters. The high quality housing consists of a frameless sheet metal structure with smooth internal and external walls. The housing is insulated with 30 mm mineral wool. There are no cold bridges. Glass-fibre sealed insulating material on the inside reduces intake and extraction noises. The FFH can be operated with three fan stages. The speed stages allow the right amount of ventilation for the requirements.

Data in detail:

- Galvanized steel housing.
- Removable aluminium cover.
- Extractable fan unit.
- Free-running, backwards curving impeller.
- External-rotor motor with integrated thermal contact, designed for continuous operation.
- Completely integrated control.
- External control unit.
- Maximum temperature: 40 °C
- Protection class: in ceiling installation with cover at the bottom and correct duct and cable connection, IP 43 (see Wiring diagram).

4.1. Device description

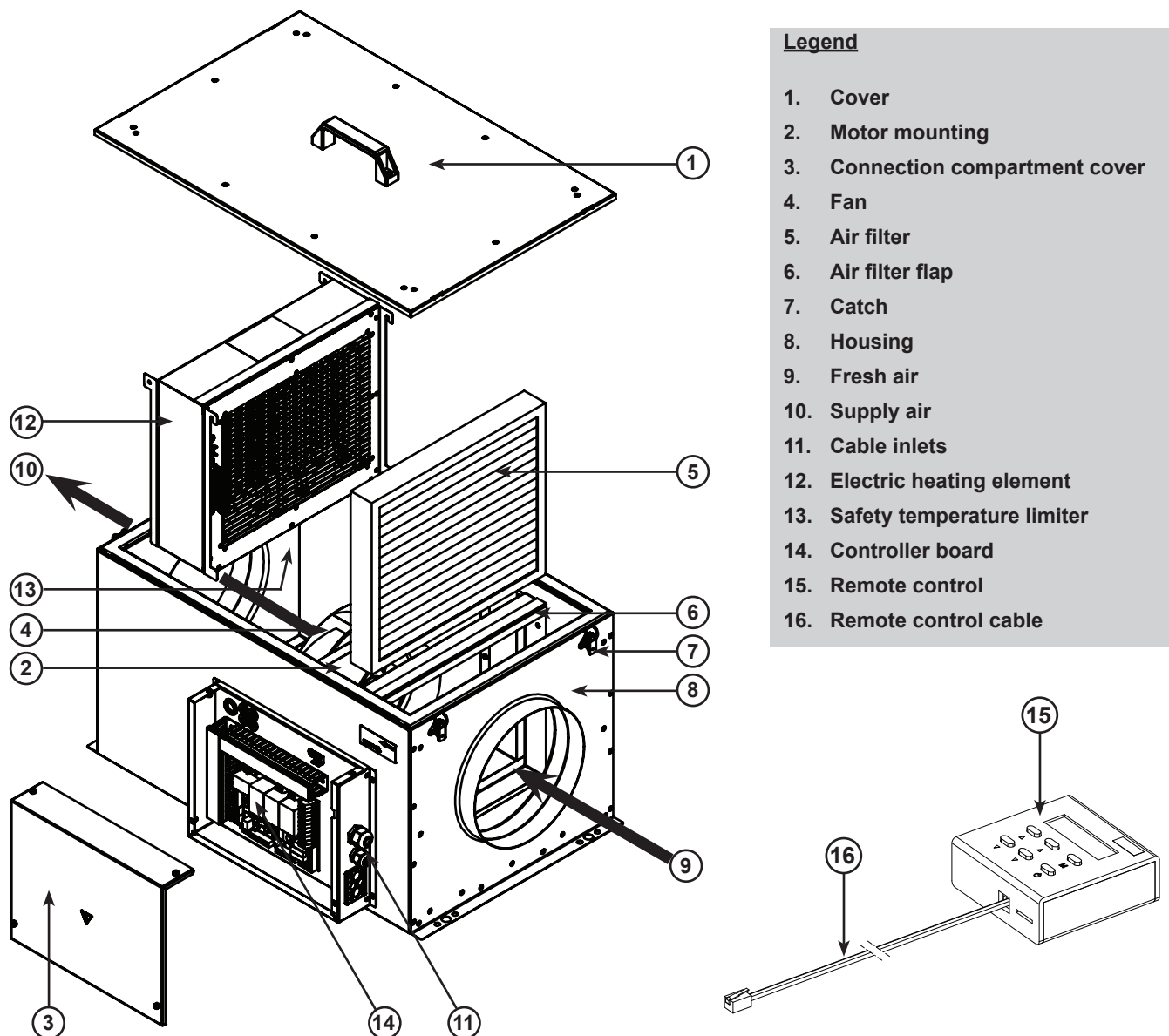



5. Transport and storage

Transport and storage should only be performed by specialist personnel in accordance with the installation and operating manual and regulations in force.

The following points should be noted and followed:

- Check the delivery according to the delivery note to ensure it is complete and correct and check for any damage. Any missing quantities or damage incurred during transport should be confirmed by the carrier. No liability is accepted if this is not observed.
- The product weighs approx. 17 - 32 kg (depending on the product type in question).
- It should be transported with suitable lifting equipment in the original packaging or on the transport equipment indicated.
- If transported with a forklift it should be ensured that the product is resting with the basic profile or base frame completely on the forks or on a pallet and the product's centre of gravity is between the forks (see Fig. 4).
- The driver must be authorized to drive a forklift truck.
- Do not go beneath the suspended load.
- Only lift and transport the machine by its base plate, never by the cover handle!
- Avoid damage or deformation of the housing.
- The product must be stored in a dry area and protected from the weather in the original packaging. Open pallets should be covered with tarpaulins. Even weatherproof modules should be covered because their weather resistance is only guaranteed after complete installation.
- Storage temperature between $-10\text{ }^{\circ}\text{C}$ and $+40\text{ }^{\circ}\text{C}$. Avoid severe temperature fluctuations.
- If the product has been in storage for more than a year, check the smooth running of impellers and valves by hand.

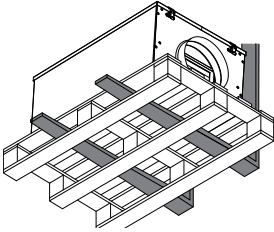

Fig. 4:
Unit transported on a pallet with a forklift.



6. Assembly

Assembly work may only be performed by specialist personnel in accordance with the installation and operating manual and the regulations and standards in force.

The following points should be noted and followed:

- The product should only be installed on ceilings with the cover on the bottom (installation height: min 1.8 m above the ground). Alternative installation positions are given in Section 6.1 „Permitted installation positions“.
- Only install in dry rooms with no condensation.
- Installation accessories should be provided by the client.
- Only suitable installation aids, in accordance with regulations, should be used.
- The installation should be easily accessible for maintenance and cleaning and should be easy to dismantle. Leave a space of at least the height of the unit + 5 cm from other units, shelves or cabinets to facilitate maintenance work such as changing the filter (see Fig. 5).
- The unit should only be installed with authorized and suitable fastening materials at all fastening points.
- It must be fastened with screws or threaded rods, minimum diameter 8 mm.
- The unit should only be installed on ceilings with adequate load-bearing capacity. Wall installations are only permitted in the positions shown in Section 6.1 „Permitted installation positions“.
- Do not distort the unit when installing.
- The unit should be suitably secured.
- No holes should be made in the housing, or any screws screwed into it.
- The duct system must not be supported on the housing.
- It is recommended that the duct system is attached with flexible connections in order to isolate any structure-borne noise.
- Make sure that the duct system cannot be closed.
- Make sure that the intake duct has direct access to the intake air.
- Warning: branches in the intake duct, to other fan units for example, may, if the dimensions are too small, lead to low pressure in the duct and therefore malfunction of the unit.
- The pressure loss in the duct system must not be more than the capacity of the unit! The pressure loss in the duct should not be more than 2/3 the unit's maximum pressure so that an adequate air output can still be achieved. This will prevent malfunction.
- Pressure losses in the duct system are adversely affected by: the length of the duct system, small pipe or duct cross-section, elbows, additional filters, valves, etc.

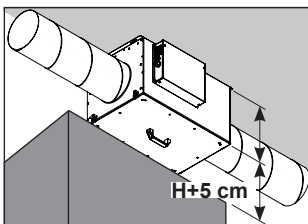

Fig. 5:
Minimum distance for maintenance work.

6.1. Permitted installation positions



Abb. 6a:
Wall installation, connections upwards.



Abb. 6b:
Ceiling installation

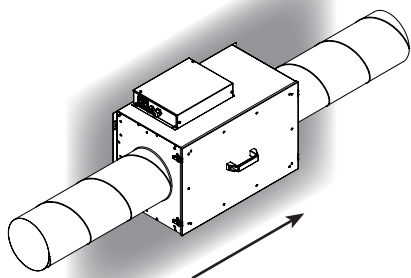

Abb. 6d:
Wall mounting connections downwards

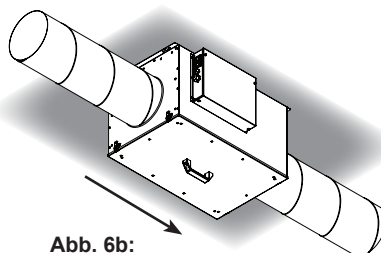

Abb. 6c:
Wall installation, air flowing upwards.

6.2. Operating limits

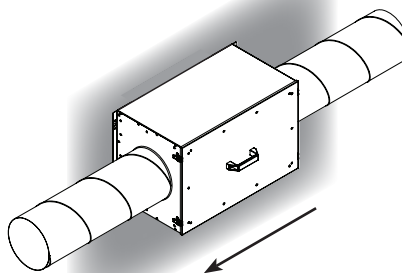
Operating limits indoor installation

Fresh air temperature	-28 °C to +40 °C
Installation place:	+5 °C / max. 15g/kg Water content of the air

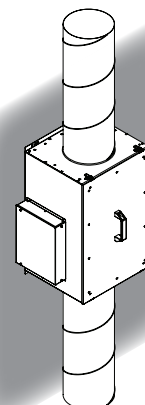
For the ventilation of rooms where the emission sources are human metabolism or building materials and structures, such as offices, spaces for public services, meeting rooms.

7. Electrical connection



- **Electricity warning (hazardous voltage)**
- » **Failure to observe the hazard may result in death, injury or damage to property.**
- **Before performing any work on conductive parts, always disconnect the unit completely from the electricity supply and make sure that it cannot be switched back on again.**

Electrical installation may only be performed by qualified electricians in accordance with the installation and operating manual and the national regulations, standards and guidelines in force:

- ISO, EN, DIN and VDE specifications, including all safety requirements.
- Technical connection conditions
- Safety at work and accident prevention requirements.
-

This list does not claim to be complete.

Requirements should be applied under one's own personal responsibility.

The following points should be noted and followed:

- The electrical connections must be made as shown in the corresponding wiring diagrams and terminal diagrams.
- The type of cable, size of cable and method of laying should be determined by an authorized electrician.
- Low and extra-low voltage cables should be laid separately.
- An all-pole mains disconnection device with at least 3 mm contact gap must be provided in the supply line.
- Use a separate cable inlet for each cable.
- Any cable inlets that are not used must be sealed so that it is airtight.
- All cable inlets must have strain relief.
- Create equipotential bonding between the unit and the duct system.
- Check all protective measures after the electrical connection work (earthing resistance, etc.).

Connection compartment / Connections on the unit



Fig. 7:
Connection chamber (1) and cable inlets (2)

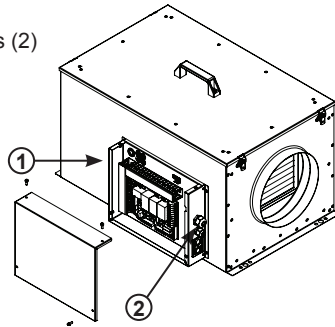
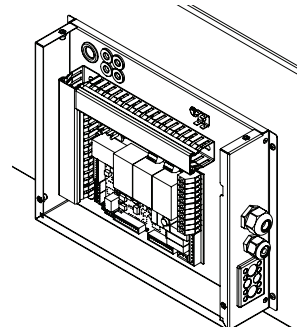

Fig. 8:
Connections to the FFH unit.



The connection compartment is located in a separate connection box outside the device. The cover of the connection box can be opened by loosening the 4 screws (see Fig. 7). Cables that carry mains voltage must be fastened with the tension relief devices available. Connection is as described in Section 7.2.

Unit supply cable

Connect the mains supply cable as shown in the wiring diagram. Suitable fuse protection should be provided.

External extraction fan

An extract fan can be connected to the terminal strip. For connection diagram see wiring diagram. Terminals for neutral conductor and earth conductor are also shown in the wiring diagram. (230 VAC, max, 2A)

Valve actuator

An actuator can be connected for an air damper. Terminal assignment for opening and closing the air dampers and connecting the neutral conductor and earth conductor (see wiring diagram). To save energy and for electrical safety, the close signal is only active for 4 minutes after the fan has been switched off (230 VAC, max. 1 A).

Unit malfunction

If there is a malfunction on the unit, an error message appears on the display and at the same time switches a relay. A closing and opening signal is available (see wiring diagram). Electrical connection of the changeover contact with U - 230 VAC and $I_{max} = 2A$.

Unit enabling

The unit can be switched on and off with an external potential-free contact (see wiring diagram). An external voltage must never be applied to this connection. The control system would be destroyed. Any devices that provide a potential-free contact (e.g. a time switch) can be used to control the unit. This contact must be securely isolated from interference voltages because otherwise dangerous conditions might occur in the event of a fault.

Control unit

The control unit is connected to the supply air unit's control system with a control cable. A connector on the control cable is plugged directly into the socket on the control unit from beneath (see Fig. 10). On the unit, the control cable is first fed through a cable gland (see Fig. 7), placed in the cable duct and then connected to the RJ10 socket provided in the controller board. The control cable must not be shortened. Any excess length must be stowed outside of the housing. If the cable is too short, extensions can be ordered from the manufacturer or supplier. Alternatively, a 4-wire data cable with 120 Ohm resistance can also be connected. This is fed through the back wall of the control unit and connected to the spring-loaded terminals. In the unit, instead of being connected to the controller board in the RJ10 socket, the cable is connected in the spring-loaded terminals next to it (see wiring diagram).

The extra-low voltage control cables must be laid separately from the mains cables.



7.1. Overcurrent protection

- The unit may only be operated with the correct overcurrent protection.
- This must be established by a qualified electrician.
- The recommended protection is shown in the enclosed wiring diagram.

8. Commissioning



- **Electricity warning (hazardous voltage)**
- » Failure to observe the hazard may result in death, injury or damage to property.
- Before performing any work on conductive parts, always disconnect the unit completely from the electricity supply and make sure that it cannot be switched back on again.



- **Never reach into the impeller or other rotating or moving parts.**
- » Failure to observe the hazard may lead to serious injury.
- Work may only be performed once the impeller has come to a complete halt.



- **Caution! Burning hazard.**
- » Failure to observe the hazard may result in personal injury and/or damage to property.
- Do not touch the surface until the motor and heater have cooled.



Commissioning by trained technical personnel may only be performed when any risk has been ruled out. The following checks should be performed in accordance with the installation and operating manual and the regulations in force:

- Correctly sealed installation of the unit and duct system.
- Check the duct system, unit and medium lines, if present, remove any foreign bodies if necessary.
- The intake opening and inflow into the unit must be clear.
- Check all mechanical and electrical protection measures (e.g. earthing).
- Voltage, frequency and type of current must correspond with the rating plate.
- Check all electrical connections and wiring.
- Check any electrical, switching, safety and control devices connected.
- The unit may not be switched on when the housing is open.
- Measure electricity consumption at operating speed and compare with the rated current.
- Check the fan for excessive vibrations and noise generation.
- The impeller must not be rubbing against the inlet nozzle or other fittings.

Warning: When the voltage is connected the blower starts up at the middle stage for about 6 sec. After four minutes the blower switches back off again automatically. In the shut-off delay the unit continues to run until the supply air temperature is at <math><40\text{ }^\circ\text{C}</math>. Then the unit turns off.

9. Operation

9.1. Control unit

The control unit enables the control and input of the unit's various functions. The control unit has an integrated temperature sensor (set-point sensor) for measuring the room temperature. The display shows the various operating parameters and error messages. You can select individual menu points or change values with the various buttons.

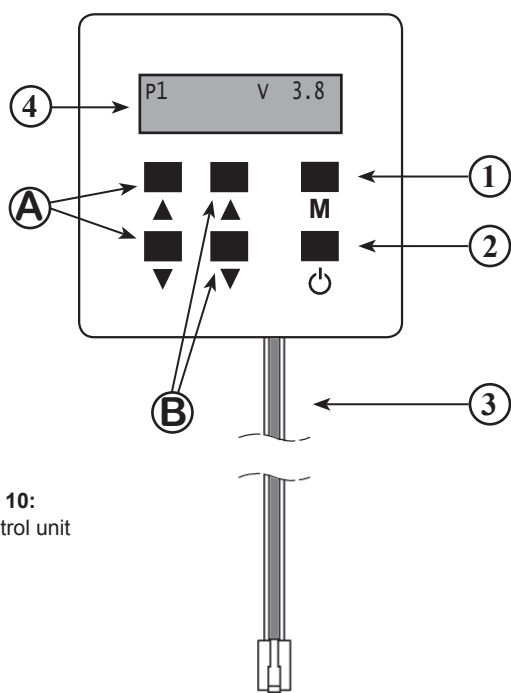
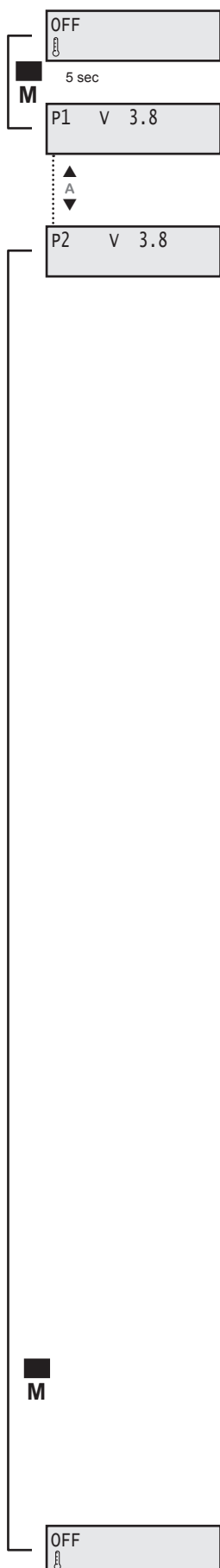

Fig. 10:
Control unit

- 1) Mode Button
Changes to the menu of the control unit parameters or used to save.
- 2) ON/OFF Button
Button for switching the unit on or off or switching to menu management.
- A) Button A:
Can be used to increase or reduce the set-point temperature in the status display or to switch through the individual operating menus or operating parameters.
- B) Button B:
Can be used to increase or reduce the fan stages in the status display or to set values in the individual operating menus or operating parameters.
- 3) Control cable
- 4) Display

	Replace battery
	Timer active
	Temperature
	Fan stage



9.1.1. Adjustment of the control unit parameter

To be able to make changes to the control unit parameter, you must press the „Mode button“ (M) for at least 5 seconds. P 1 will appear on the display. Use button A (▲) to change to your desired parameter.

P 1 Unit control system

This parameter shows the software version number.

P 2 Language setting

Use button A (▲) to change to parameter language setting P 2. Now press button B (▲) and the control unit will change to input mode. You can now use buttons A (▲ and ▼) to select the language required.

Press button B (▲) again to accept the language selected.

Then press the „Mode button“ (M) for at least 2 seconds. The parameters will be saved and the menu will close. The display switches into operating mode.



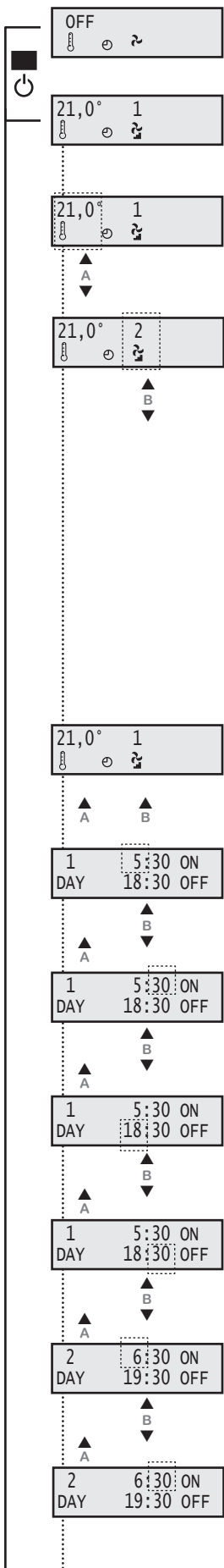

9.1.2. Menu functions control unit

Switching the unit on/off on the control unit.

Press the ON/OFF button (2) to switch the unit on or off. The unit's status now appears on the display with the current values.

- ⌋ » Set-point temperature display
- ⊖ » Time switch is on.
- ⌋ » Fan stage

Changing the set-point temperature

When commissioning for the first time, a set-point value of 21 °C is given. This value is shown on the left-hand side of the display. The set-point value can be increased (▲) or reduced (▼) on the control unit using buttons A. (The setting range is limited by parameters P 1 and P 2.)

Changing fan stage

There are two possibilities for selecting the fan stages: automatic and continuous mode. Press buttons B (▲ and ▼) at the same time to switch between the two modes. Automatic mode is indicated on the display by the regular flashing of the fan stage selected.

- **Continuous mode**

- » In continuous mode, the fan stages can be selected with buttons B (▲ and ▼) on the control unit. The control system does not then affect the speed of the fan (except for in the case of a fault). Continuous mode can be seen by the constant display of the fan stage on the display.

- **Automatic mode**

- » In automatic mode the fan will always try to run in the highest possible stage. If the set-point temperature set is not achieved by this, it switches to a lower fan stage to be able to ensure a constant room and exhaust air temperature.

9.1.3. Time / Time switch

9.1.3.a. Setting the time switch

The control unit has an integrated time switch. This can be used to control the time your unit will come on, individually for each day of the week.

Setting the time switch

With the setting parameters for the time switch, the times when the unit is to come on (ON) or off (OFF) can be set individually for each day of the week.

From the status display, press button A (▲) and B (▲) to get to the menu for setting the time switch.

On the display, on the top line, the display flashes for the „hour“ in which the unit is to come on (ON) on day 1. Press buttons B (▲ and ▼) to set the „hour“ and then confirm the entry with button A (▲). The display then moves on to the „minutes“ which can be set in the same way with buttons B (▲ and ▼) and confirmed with button A (▲). (The minutes are set in 5-minute increments.)

Set	Day
1	Monday
2	Tuesday
3	Wednesday
4	Thursday
5	Friday
6	Saturday
7	Sunday

On the display, on the bottom line, the display now flashes for the „hour“ in which the unit is to switch off on day 1. The „hour“ and „minutes“ are again set and confirmed with buttons B (▲ and ▼) and button A (▲). Once the entry has been confirmed, the display moves on to day 2 where the individual on and off times can be set. Days 3 to 7 then follow.

Once you have set all of the parameters / days, press the „Mode button“ (M) to go back to the unit's status display.

However, you do not have to go through the whole time switch menu to get back to the status display. You can press the „Mode button“ (M) at any time to go back to the status display.

Note:

- If the time 0:00 is given in the parameters, the unit will not switch on or off.
- If, for example, you do not want the unit to come on at the weekend, you should set the value to 0:00 for „Day 6“ and „Day 7“.
- The values set are saved even when there is a power failure or if the battery in the control unit runs down. Only the current time and day of the week have to be reset.

Note: Instructions on changing the clock battery are give in section 10.3.2.

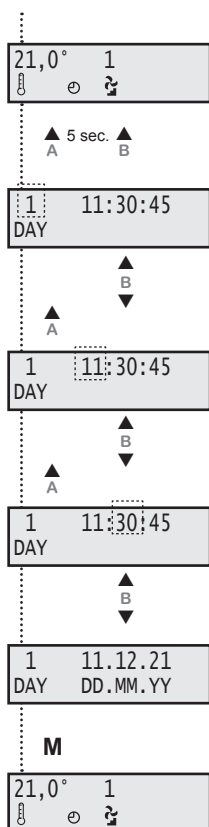

9.1.3.b. Set current date/time/day of week

By pressing the A (▲) and B (▲) keys simultaneously for approx. 5 sec. you will access the menu for setting the current time, day of the week and date.

The display shows the current time and day set. Above the „DAY“ display there is a value indicating the current day of the week.

When the value is flashing you know that you can now set it. Press buttons B (▲ and ▼) to set the current day of the week (see table). Press button A (▲) to confirm the set value.

On the display, the „hour“ now starts to flash. The hour is set by again pressing buttons B (▲ and ▼) and then confirmed with button A (▲). The display then moves to „minutes“ which can be set in the same way with buttons B (▲ and ▼) and confirmed with button A (▲).

Set	Day
1	Monday
2	Tuesday
3	Wednesday
4	Thursday
5	Friday
6	Saturday
7	Sunday

Setting the date is analogous to setting the time

Press the „Mode button“ (M) to go back to the status display.

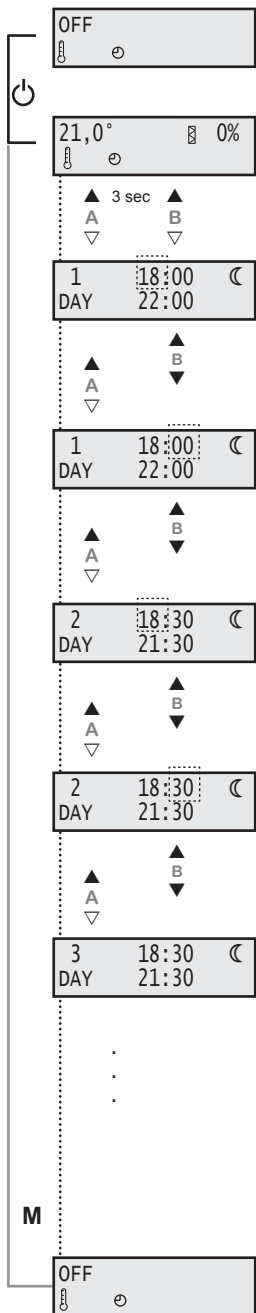

9.1.3.c. Setting day - night switch-over

This menu works similar as the timer, however it does not set the on (ON) and off (OFF) times, but the times when the unit switches from day to night mode.
 The device runs in day mode with the basic ventilation volume flow.
 The device runs in night mode with the minimum ventilation volume flow.

On the display, push button A (▲) and B (▲) simultaneously for approx. 3 seconds to get to the menu for day-night switch-over.

The display flashes on the top line for the time point in which the device starts the night mode on day 1 (Monday). Press buttons B (▲ and ▼) to set the „hour“ and then confirm the entry with button A (▲). The display then moves on to the „minutes“ which can be set in the same way with buttons B (▲ and ▼) and confirmed with button A (▲).
 (The minutes are set in 5-minute increments)

Set	Day
1	Monday
2	Tuesday
3	Wednesday
4	Thursday
5	Friday
6	Saturday
7	Sunday

The display now flashes on the bottom line for the time point in which the device stops the night mode on day 1 (Monday). The „hour“ and „minutes“ are again set and confirmed with buttons B (▲ and ▼) and button A (▲).

Once the entry has been confirmed, the display moves on to day 2 where the individual on and off times can be set. Days 3 to 7 then follow.

Once you have set all of the parameters / days, press the „Mode button“ (M) to go back to the unit's status display.

However, you do not have to go through the whole time switch menu to get back to the status display. You can press the „Mode button“ (M) at any time to go back to the status display.

Note:
 If the time 0:00 is given in the parameters, the unit will not switch to night operation.

The values set are saved even when there is a power failure or if the battery in the control unit runs down. Only the current time and day of the week have to be reset.

Note: Instructions on changing the clock battery are give in section 10.3.2.

Switching the time switch on and off.

The time switch can be switched on and off as required.
 From the status display you can switch the time switch on or off by pressing button A (▼) and B (▼) at the same time.

When the time switch is on, a continuous clock symbol is shown on the display.

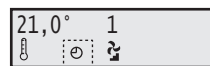

Time switch on

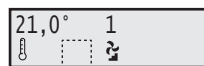

Time switch off

Fig. 16:
Systematic drawing without
timer settings

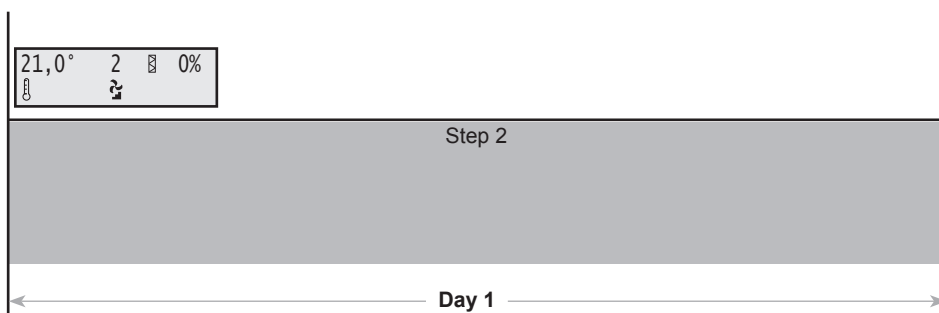

Fig. 17:
Systematic drawing for timer
settings

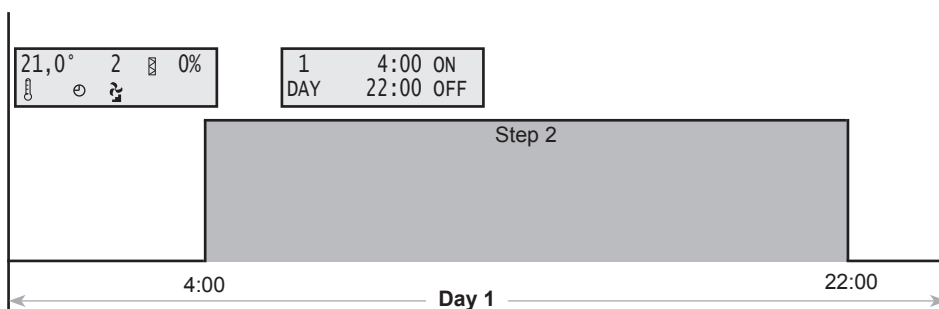
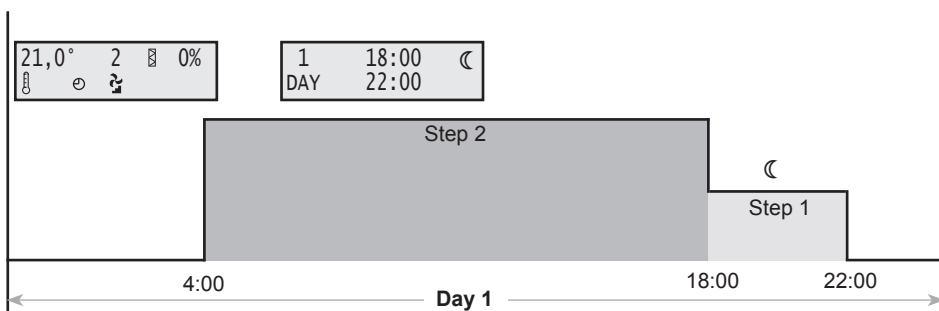

Fig. 18:
Systematic drawing for timer
and day-night switch-over
settings



9.2. Operation of the menu

- a. To enter in the menu keep the ON/OFF key pressed for approx. 4 seconds.
- b. With the two keys A from left (▲ and ▼) you can move within the current level.
- c. Use the middle upper key B (▲) to select the menu item.
- d. If you are within the menu, you can return to the higher menu level by briefly pressing the ON/OFF key.
- e. If you are already at the top level, you can exit the menu by pressing the ON/OFF key.
- f. The menu consists of 4 levels and 7 main menu points (top level). Each of these menu items can be both a submenu and a value.

For orientation, there is an orientation bar on the left side of the display. Here you can see on which of the 4 levels and in which of the up to 99 submenu levels you are.



- g. The following special characters are used for menu guidance (entry into the menu items):



Menu selection (with key B (▲))



Menu selection resp. value changeable (with key B (▲))

- h. Some menu items have an additional INFO page as well (only for customer service purposes). This is switched on/off with the „Mode“ key (M). When the „Info page“ is switched on, „INFO“ flashes in the lower right corner of the display.
- i. The system is accessed in 4 access levels, which control both the display of menu items and the rights to change settings.
 - a. Access level 1: „Standard operation“
Access to settings is largely restricted.
Only elementary menu items are displayed.
 - b. Access level 2: „Extended standard operation“
The system runs normally. There are extended setting options.
Additional menu items are displayed.
 - c. Access level 3: „Commissioning access level“
All available settings can be changed.



In this Access-Level the device cannot be started. Please change to Access-Level 1 or 2.

- d. Access level 4: „Service operation“
Like Access level 3, but with extended service functions.



In this Access-Level the device cannot be started. Please change to Access-Level 1 or 2.

- j. If parameters or other settings have been changed, the change is permanently transferred to the memory by holding down the „Mode“ key (M). In the lower right corner of the display you can see a countdown. This concludes with either „OK“ or a key (access denied).
If you leave the menu without saving, the changes will be discarded.

9.2.1. The main menu items

Press and hold the ON/OFF key to enter the menu.

The individual menu points can be called up with buttons A (▲ and ▼) on the control unit. The keys B (▲ and ▼) can be used to switch to the menu items or to change the values.

By holding down the „Mode“ key (M) (1-2-3-ok) changes are accepted into the memory.

Press the ON/OFF key to exit the submenu. (Unsaved changes will be discarded!)

If the settings prove successful, it is recommended to create a backup. (06/02/02/00)

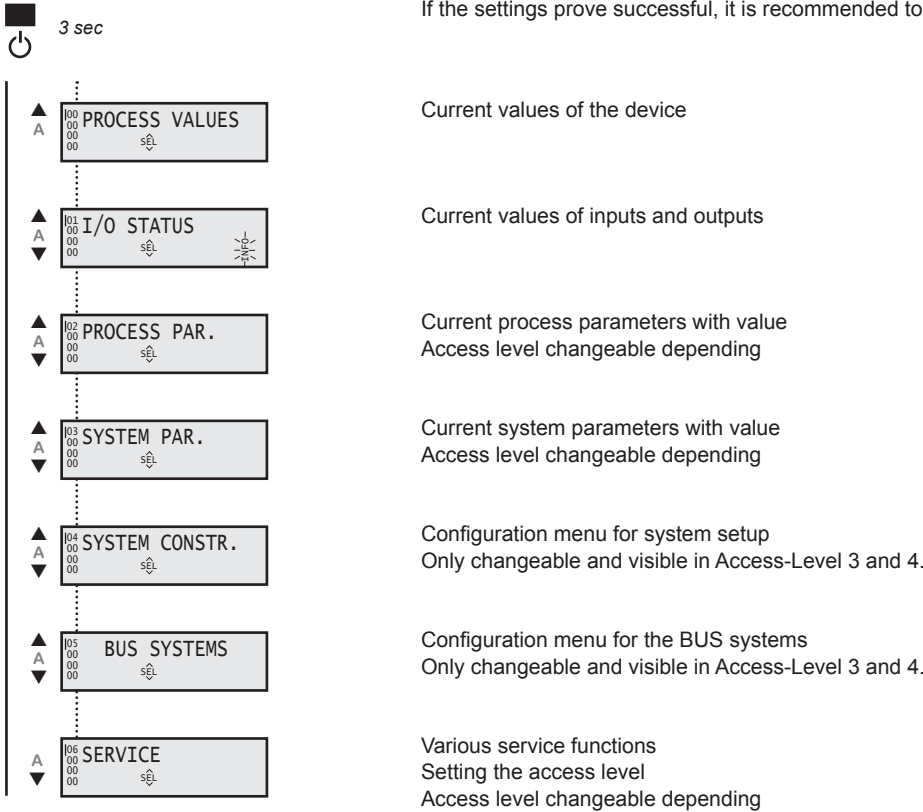

9.2.2. Menu „Process values“ (00/00/00/00)

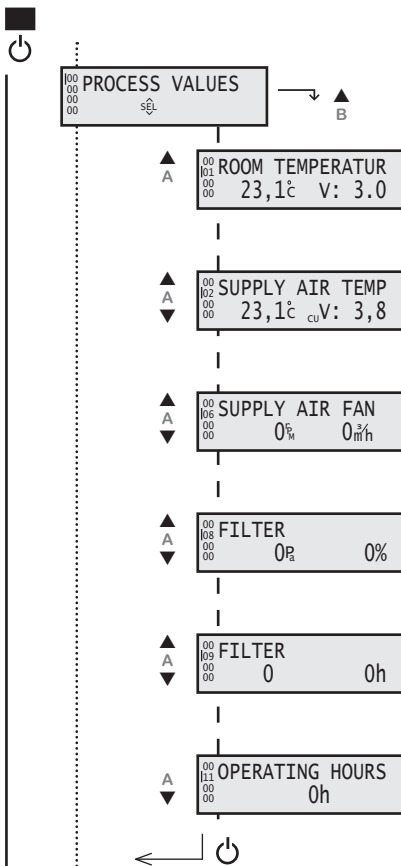

Current values of the device

Room temperature (00/01/00/00)

The current value of the prevailing room temperature is displayed here, measured by the sensor in the control unit or a connected external sensor. The settings for the measuring point of the room temperature (control unit or external sensor) are made under parameter P42. (02/42/00/00) The value after V indicates the software version installed.

Supply air temperature (00/02/00/00)

The current value of the prevailing air supply temperature is displayed here, measured by a temperature sensor in the device, in the flow area of the supply air. The value after V indicates the software version installed on the control unit!

Status supply air fan (00/06/00/00)

The current speed and volume flow of the supply air fan is displayed here.

Filter status (00/08/00/00)

Current filter pressure drop in Pascal & degree of contamination in %.

Filter change counter (00/09/00/00)

Display of the filter changes made and the operating hours of the current filter. The number of filters changes increases automatically after a proper filter change. The operating hours counter is reset.

Further information and notes on filter replacement can be found in chapter 10.3.1 „Air filter“ in these operating instructions.

Hours of operation (00/11/00/00)

The current number of hours for which the unit has been in constant operation.

9.2.3. Menu „I/O Status“ (01/00/00/00)

Display of the values of the individual inputs and outputs.

The „M“ key can be used to switch between the standard view (left column) and the service view (right column).

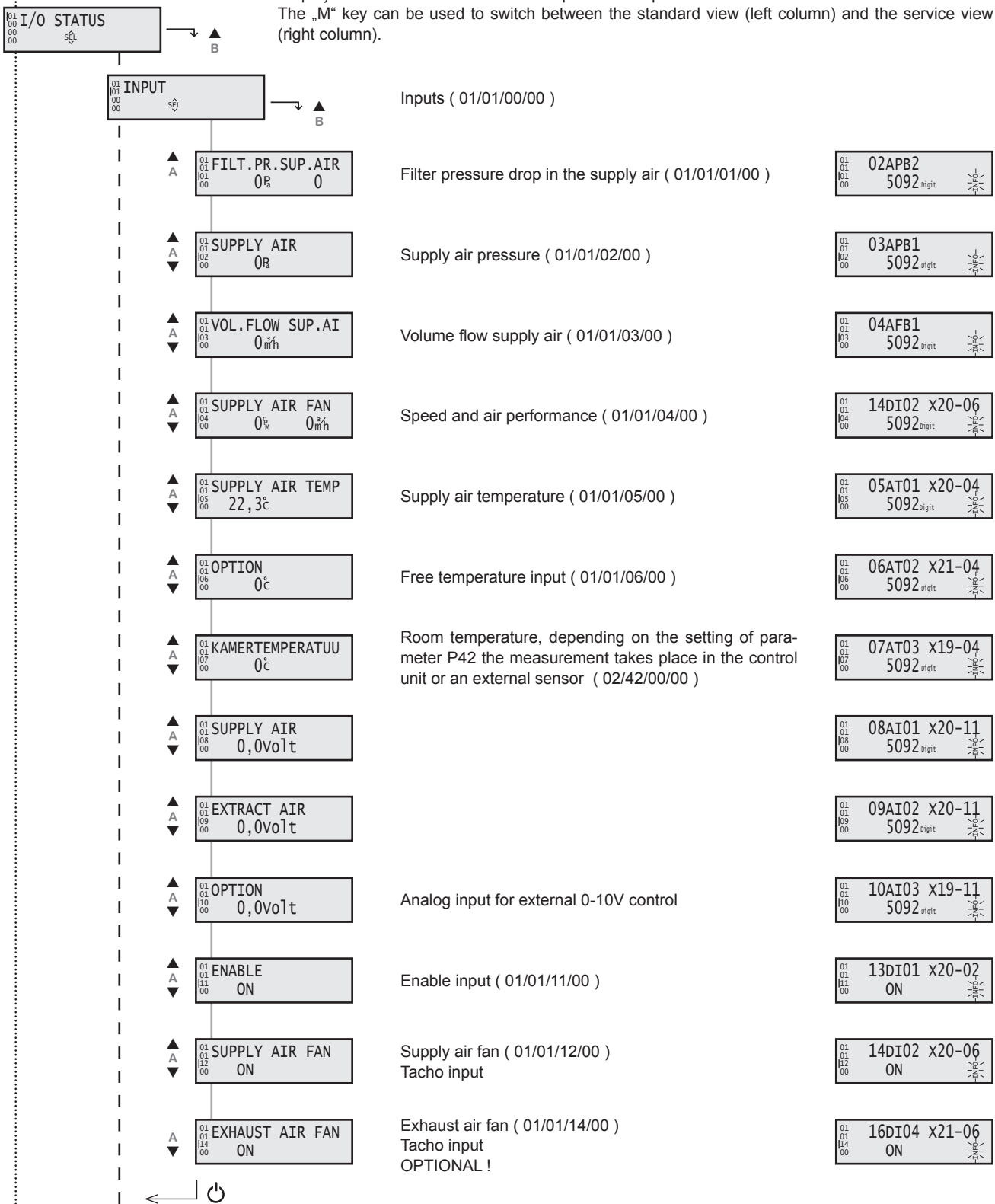

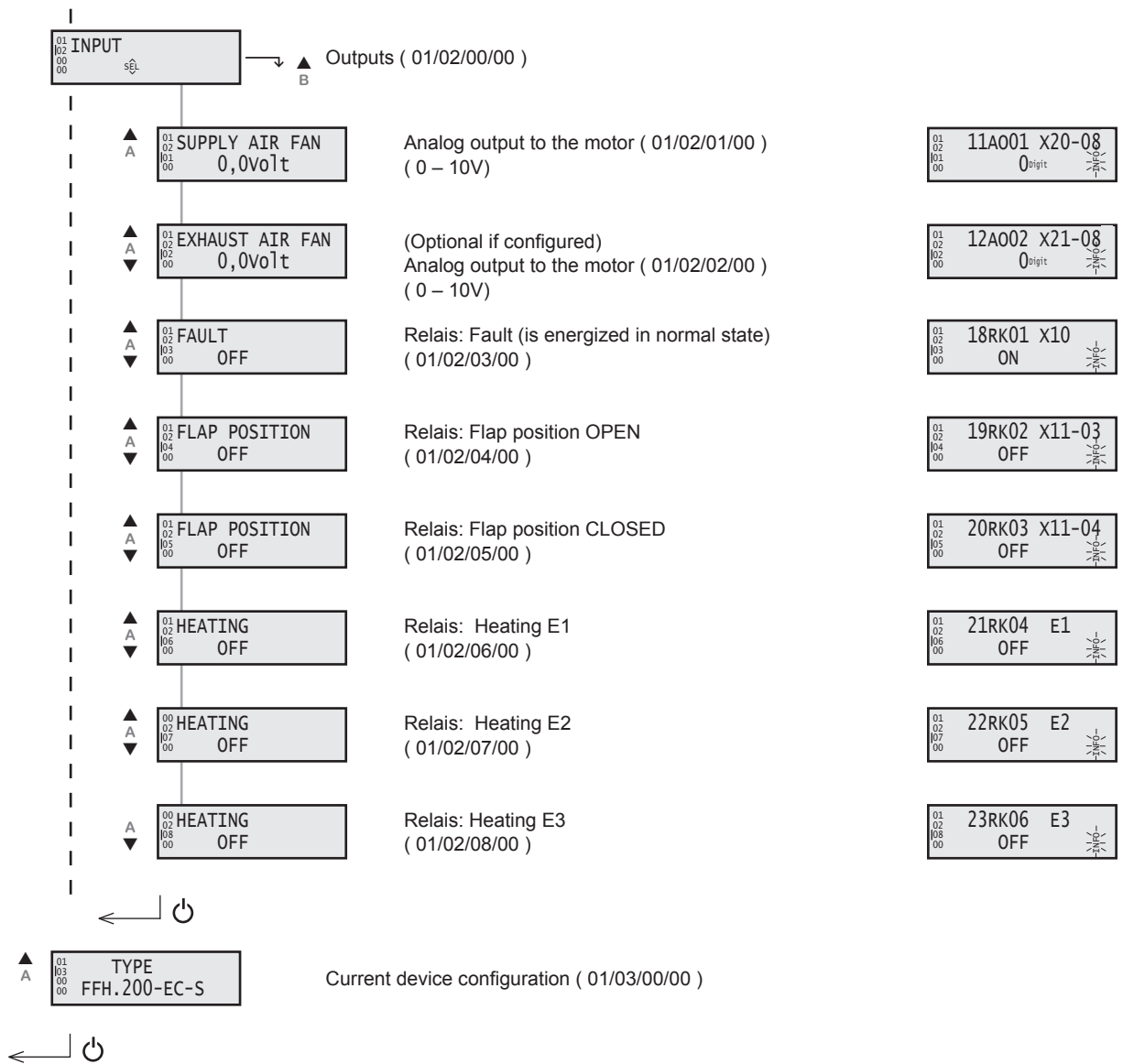

9.2.4. Menu „Process parameters“ (02/00/00/00)

Current process parameters with value.
Changeable from access level 2.

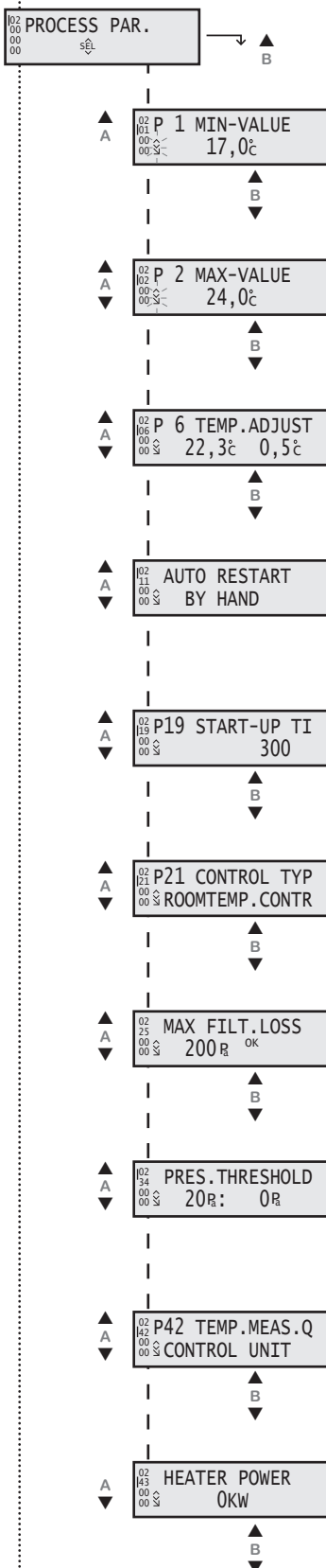

P1 Minimum set-point value (02/01/00/00)

The parameter P 1 specifies the minimum adjustable setpoint temperature, which you can set on the control unit. Values between 5 °C and 20 °C can be selected. The factory setting is 17 °C.

P2 Maximum set-point value (02/02/00/00)

The parameter P 2 specifies the maximum adjustable setpoint temperature, which you can set on the control unit. Values between 21 °C and 30 °C can be selected. The factory setting is 28 °C.

P6 Temperature correction (02/06/00/00)

Temperature correction of the actual value measurement +/- 5°C

Auto Restart (02/11/00/00)

only changeable in access level 3.

Setting of the restart behavior after power failure. Ex works, the device must be restarted manually („By Hand“) after a power failure.

The B keys (▲ and ▼) can be used to change this so that the device starts automatically after a power failure, if it was running before the power failure.

Save the setting with the „Mode“ key (M).

P19 Start-up time (02/19/00/00)

only changeable in access level 3.

P21 Type of regulation (02/21/00/00)

only changeable in access level 3.

Room temperature control

Supply air temperature control

Changes can be made with the B keys (▲ and ▼).

Save the setting with the „Mode“ key (M).

Max Filter loss (02/25/00/00)

Permissible pressure drop across the filter. Corresponds to 100% degree of contamination.

Pressure threshold (02/34/00/00)

Only changeable in access level 4

P42 Temperature measuring source (02/42/00/00)

Temperature measurement source at room temperature control

The B keys (▲ and ▼) can be used to switch between the sensor integrated in the control unit or an externally connected temperature sensor (NTC 5k, see wiring diagrams for connection).

only changeable in access level 3.

Save the setting with the „Mode“ key (M).

Heating levels (02/43/00/00)

Limitation of the available heating power.

Changes can be made with the B keys (▲ and ▼).

Save the setting with the „Mode“ key (M).

9.2.5. Menu „System parameters“ (03/00/00/00)

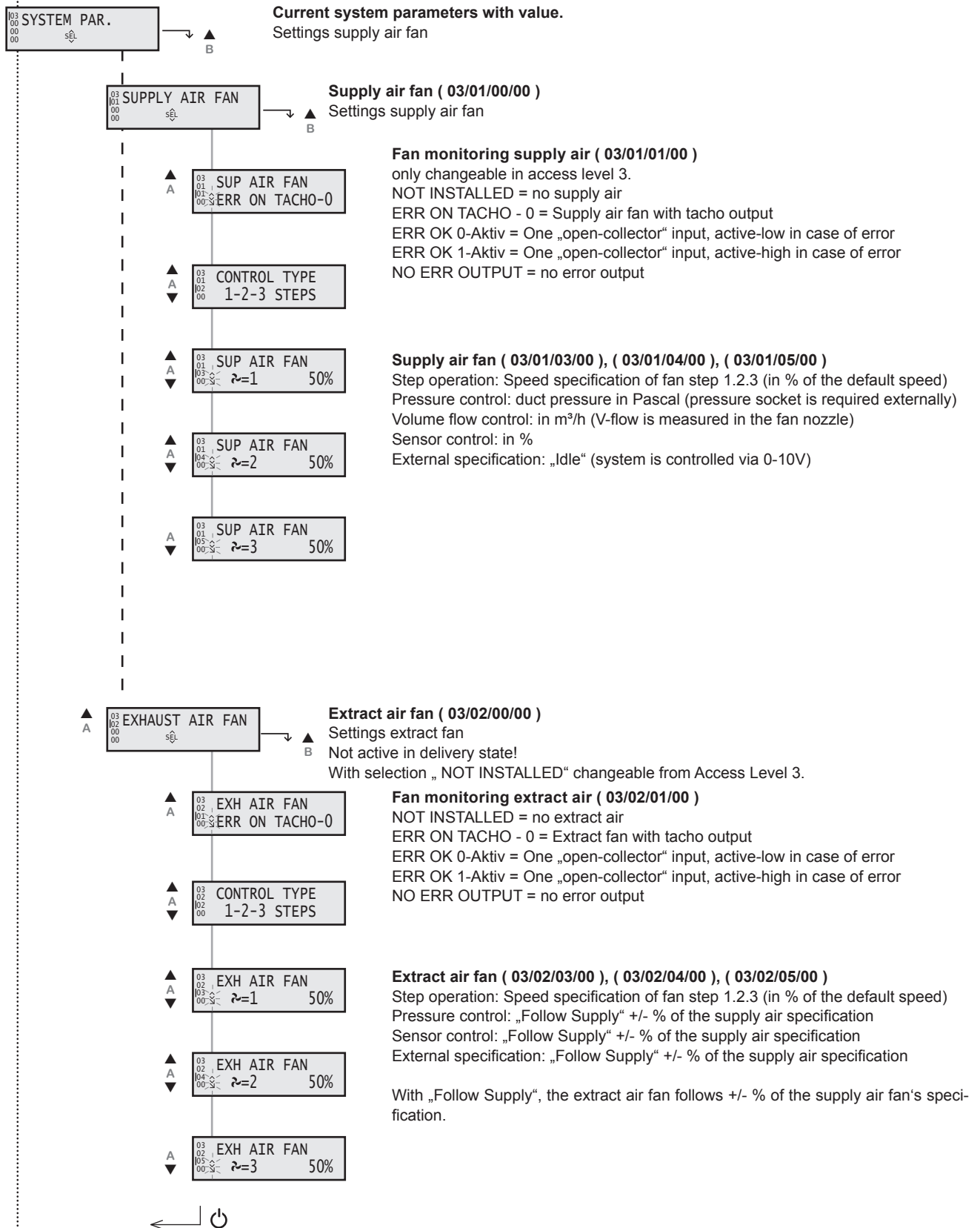

9.2.6. Menu „System setup“ (04/00/00/00)

In this menu the control mode and the external sensors can be configured.

This menu item is only visible and changeable from access level 3. For this purpose, the device must be stopped via the control unit and the password for access level 3 must be entered in the service menu. (06/01/02/00) For details see chapter 9.2.7

04
00
00
00
SYSTEM CONSTR.
sE

▲ B

▲ A
04
01
00
00
P12 TYPE
FFH.125-EC

Selection of device type (04/01/00/00)

▲ A
▼ A
04
02
00
00
P13 CONTROL TYP
FFH.125-EC-S

Selection of control type (04/02/00/00)

1.1. Stepped control

▲ B
▼ B
04
02
00
00
P13 CONTROL TYF
FFH.125-EC-S

The settings of the individual steps are described in chapter 9.2.4 „System parameters menu“ for the supply air fan and the extract air fan.

1.2. Pressure control

▲ B
▼ B
04
02
00
00
P13 CONTROL TYP
FFH.125-EC-P

The settings of the individual steps are described in chapter 9.2.4 „System parameters menu“ for the supply air fan and the extract air fan.

1.3. Volume flow control

▲ B
▼ B
04
02
00
00
P13 CONTROL TYP
FFH.125-EC-V

The settings of the individual steps are described in chapter 9.2.4 „System parameters menu“ for the supply air fan and the extract air fan.

1.4. Control via external 0-10V signal

▲ B
▼ B
04
02
00
00
P13 CONTROL TYP
FFH.125-EC-EXT

External fan speed via 0 - 10 V input (see wiring diagram)

1.5. Control via external sensor

▲ B
▼ B
04
02
00
00
P13 CONTROL TYP
FFH.125-EC-SEN

Control fan speed on demand via external sensor.
Further settings are necessary:



1.5.1. The desired sensor is set in the menu item 03 System parameters - 04 Config nodes - 08 Analog input 8, Sensor connection - Sensor settings:

▲ B
▼ B
03
00
00
00
SYSTEM PAR.
sE

03
04
00
00
CONFIG NODES
sE

03
04
08
00
LNODE 8 IANA
SENVOC 80

1.5.1.1. Setting the set point

▲ B
▼ B
03
04
08
03
LNODE 8 IANA
SETSCL 1000ppm

1.5.1.2. Setting the dead time (03/04/08/08)

▲
B
▼
03 LNODE 8 IANA
04
08 DEADTM 10,0s

1.5.1.3. Setting the measuring range (0V). These settings are to be taken from the measuring range of the transmitter used. (03/04/08/09)

▲
B
▼
03 LNODE 8 IANA
04
08 X-MIN 0 ppm

1.5.1.4. Setting the measuring range (10V). These settings are to be taken from the measuring range of the transmitter used. (03/04/08/10)

▲
B
▼
03 LNODE 8 IANA
04
10 Y-MAX 1000 ppm

1.5.1.5. Setting an offset (03/04/08/11)

▲
B
▼
03 LNODE 8 IANA
04
11 Z-OFFS 1000

1.5.1.6. Setting the sensor type (03/04/08/14)

▲
B
▼
03 LNODE 8 SENVOC
04
14 SCILL 80 ↑

Setting for external VOC sensor

▲
B
▼
03 LNODE 8 SENC02
04
08 SCILL 81 ↑

Setting for external CO2 sensor

▲
B
▼
03 LNODE 8 SENHYM
04
08 SCILL 85 ↑

Setting for external humidity sensor



9.2.7. Menu „BUS Systems“ (05/00/00/00)

05 00 00 00
BUS SYSTEMS
sE

Configuration menu for the BUS systems.
Access level changeable depending

05 01 00 00
MODBUS
sE

Select Modbus (05/01/00/00)

▲
A
▼
05 01 01 00
P 8 BAUD RATE 0
9600 BAUD

Baud rate selection (05/01/01/00)

▲
A
▼
05 01 02 00
P 7 ADDRESS
1

Address setting (05/01/02/00)

▲
A
▼
05 01 03 00
P50 BUS MODE
8-N-1 0

Protocol setting (05/01/03/00)



9.2.8. Menu „Service“ (06/00/00/00)

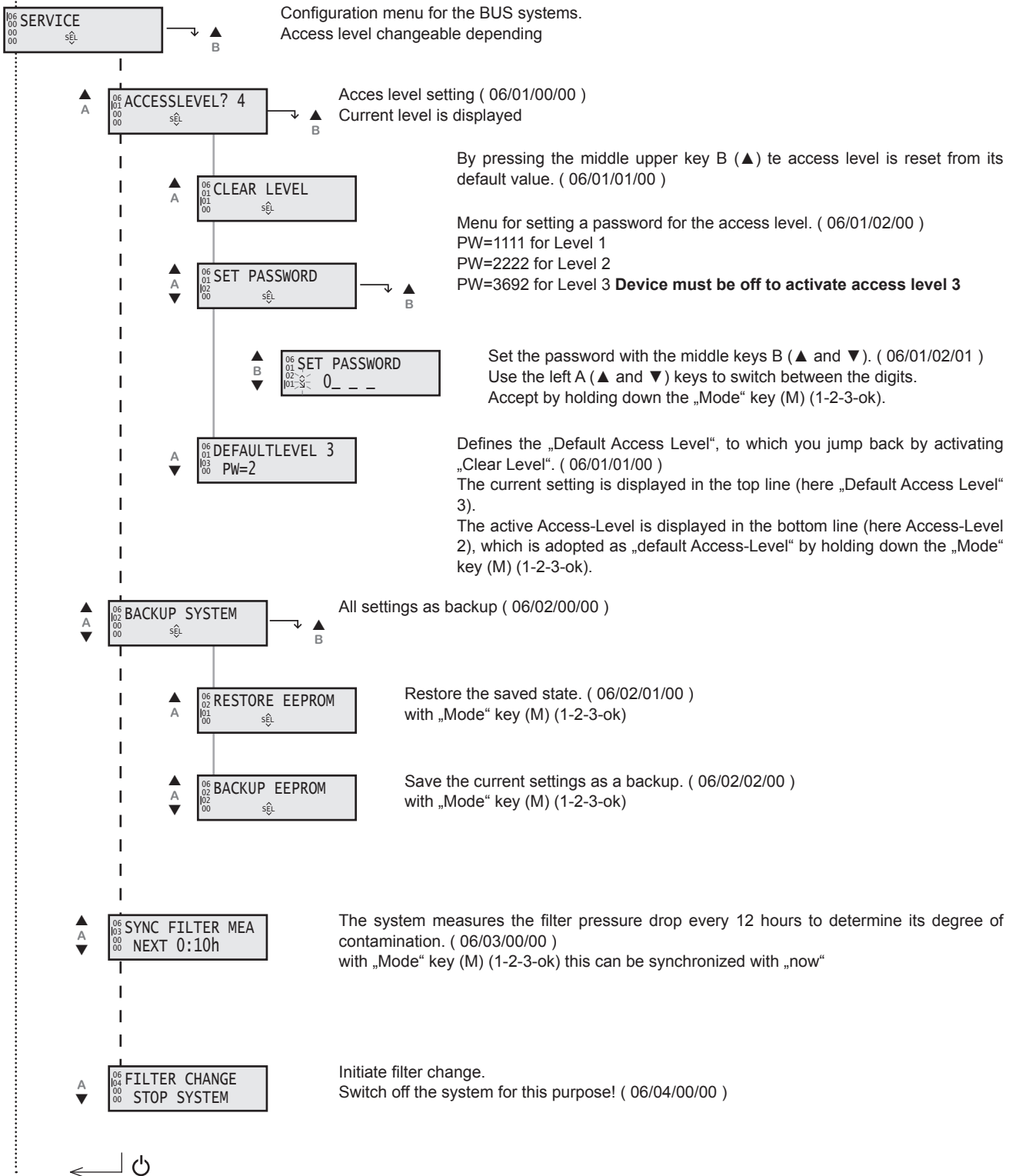

9.3. Additional functions

Start at low external temperatures

By switching on the appliance, it can take some time until the electric heating element reaches operating temperature. A special start-up automation will avoid that cold air is blown into the room during this time. If the supply air temperature drops by more than 2 °C from the setpoint, the control system switches on the fan at low speed and checks whether the setpoint has been reached. The appliance switches to the selected operation mode, if the temperature reaches a higher value as the set value minus 2 °C. The control unit also changes to normal operation mode, if 7 minutes exceed the time during start-up automation.

Thermal contact

The motor has a thermal contact that opens when the permissible motor temperature is exceeded. The unit switches off when the contact opens. The fan will start again automatically once the motor has cooled down, i.e. when the contact closes.

No error message is given.

Supply air temperature limit

If there are large temperature differences between the specified set-point temperature and the measured temperature, this may lead to the introduction of very hot air in the case of room air temperature control. This high supply air temperature can lead to a deterioration of the air quality in the room. To prevent this, in the case of heating, the supply air temperature is limited to a maximum value of approximately 35 °C.

Electric heating element

The electric heating element has continuous output control. A safety temperature limiter (STB) switches the electric heater off, in the event of a fault, when the temperature reaches 75 °C. Once the safety temperature limiter (depending on model with 2 or 3 limiters) has been tripped, it has to be reset manually (see Fig. 11). Before resetting the temperature limiters and reinstalling the inserts the cause for tripping of the STB needs a troubleshooting.

Filter monitoring

After a set time, the filter display reminds you that the air filter has to be changed. A detailed description of changing the air filter is given in Section 10.3.1.

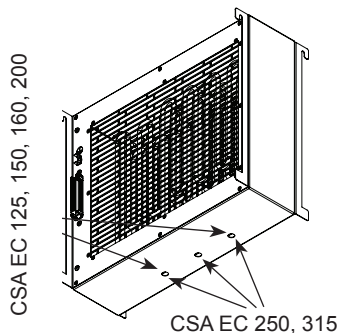

Fig. 11:
Reset buttons safety temperature limiter

10. Maintenance and repair

10.1. Important notes



- **Electricity warning (hazardous voltage)**

- » Failure to observe the hazard may result in death, injury or damage to property.

→ Before performing any work on conductive parts, always disconnect the unit completely from the electricity supply and make sure that it cannot be switched back on again.



- **Never reach into the impeller or other rotating or moving parts.**

- » Failure to observe the hazard may lead to serious injury.

→ Work may only be performed once the impeller has come to a complete halt.



- **Caution! Burning hazard.**

- » Failure to observe the hazard may result in personal injury and/or damage to property.

→ Do not touch the surface until the motor and heater have cooled.



Maintenance and repairs may only be performed by specialist personnel in accordance with this installation and operating manual and the regulations in force.

Do not repair defective or damaged units yourself, but report the damage or faults to the manufacturer in writing.



- **Unauthorized repairs may cause personal injury and / or damage to property, in which case the manufacturer's guarantee or warranty will not apply.**

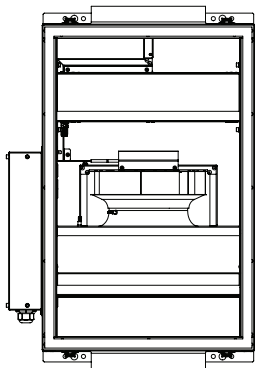

Fig. 12:
Maintenance



10.2. Cleaning and care

Servicing, troubleshooting and cleaning may only be performed by specialist personnel in accordance with this installation and operating manual and the regulations in force.

If operated correctly, **Maico** products only require a small amount of maintenance.

The following work should be performed at regular intervals, in accordance with health and safety regulations:

- Check the operation of the control system and safety devices.
- Check electrical connections and wiring for damage.
- Remove any dirt from the fan impeller or impellers and from inside the fan housing in order to prevent any unbalance or reduction in output.
 - » Do not use aggressive or easily flammable products for cleaning (impellers/housing). Preferably only water (not flowing water) or mild suds should be used.
 - » The impeller should be cleaned with a cloth or brush.
 - » Never use a high-pressure cleaner.
 - » Balancing clips must not be moved or removed.
 - » The impeller and fittings must not be damaged in any way.
- Check the operation of the bearing with a visual inspection and by checking running noise.
- Check the unit for leaks on the air side.

Before putting the unit back into operation after maintenance and servicing work, carry out a visual inspection as described in Section 7.

10.3. Maintenance

10.3.1. Air filter

The differential pressure increases as one of the air filters becomes more clogged. When the pressure reaches the value set on the corresponding pressure sensor, this can be seen on the status display. The filter must be changed when the level of clogging reaches 100%.

To ensure that the air filter is changed correctly, proceed as follows:

- The air filter can be removed without the use of tools.
- The air filter should be replaced if severely clogged.
- When changing the filter, make sure that the filter frame is sitting correctly on the guide rail in the device.
- Finally, the filter display should be reset and the new air filter calibrated (see Section 9.2.8. Menu „Service“)

Find filters positions in the device description or safety instructions.

Status display



Reset the display:

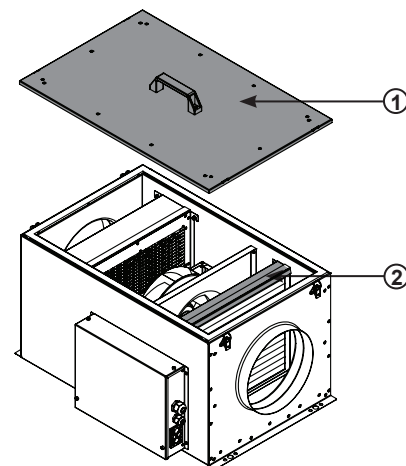
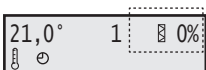

Fig. 13:
Remove cover (1) and loosen air filter flap (2)

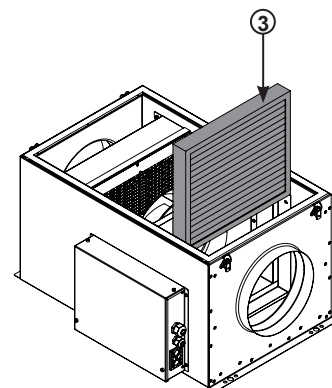

Fig. 14:
Take out the air filter (3) and replace.

10.3.2. Changing the battery

The battery's operating capacity is checked when voltage is applied to the unit.

A dead battery is indicated by a battery symbol in the status display. Change the battery as follows:

- Remove the control cable (1) from the control unit.
- Open the control unit by removing the cover (2).
- The holder (3) for the battery is on the board. Remove the battery and replace it with a new one as shown in Fig. 15 C.
- The control unit can now be closed again and the control cable connected again.
- You only have to reset the current time (see Section 9.1.3.b). The battery symbol disappears from the status display. Your control unit is fully functional again.

Status display

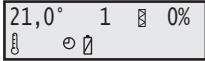

Reset the display:

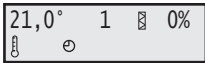

Note: requires a 3 V lithium CR 1616 button cell battery.

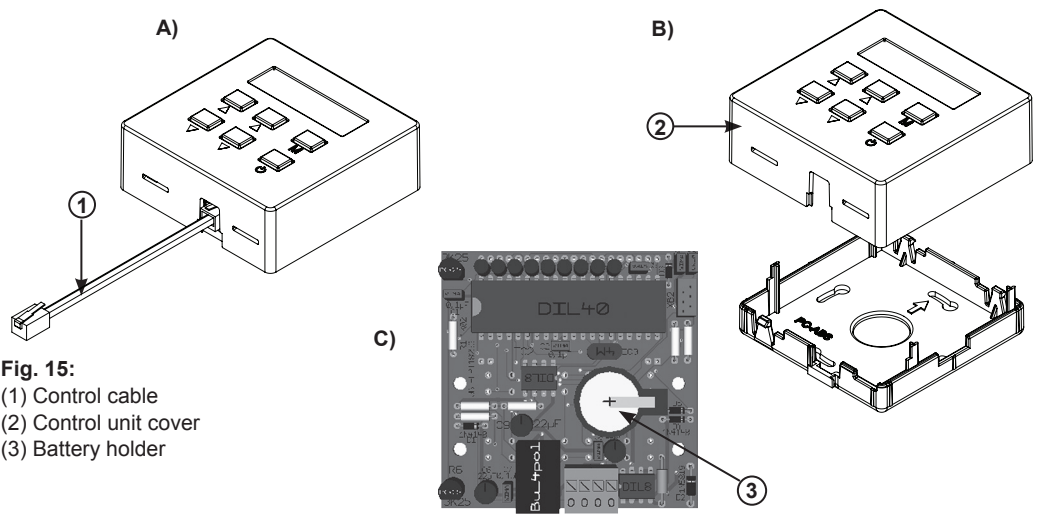
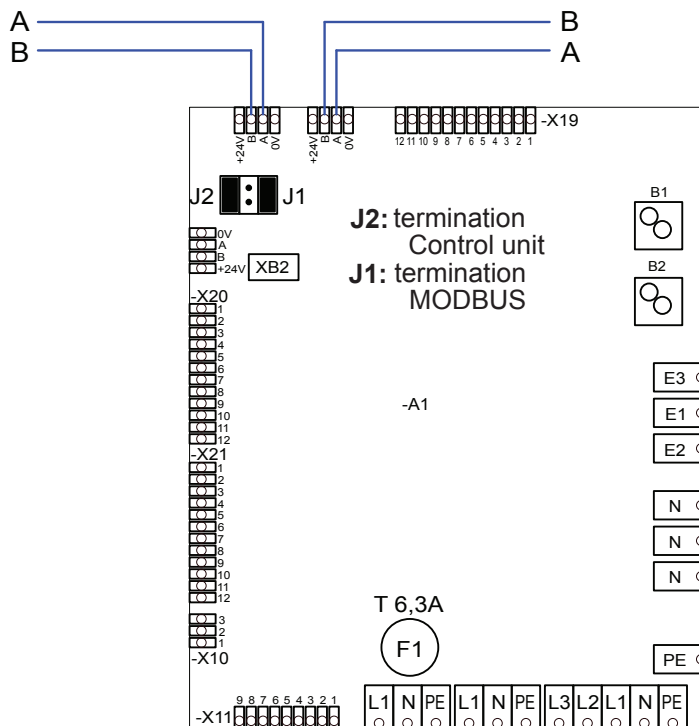

Fig. 15:
 (1) Control cable
 (2) Control unit cover
 (3) Battery holder

11. Modbus communication interface

11.1. Wiring diagram



11.2. Interface information

The device works as a Modbus RTU slave. The interface configuration is 8N1, 9600Baud, slave address 1. The address and the baud rate can be set as described in the chapter „BUS Systems“. As bus line is recommended a twisted pair data cable with 120 Ohm impedance.

11.3. Functions implemented

Function code	Name	Description
03 Hex	Read Hold Register	Read device parameter
04 Hex	Read Input Register	Read current value
06 Hex	Write Single Register	Write device parameter word by word
10 Hex	Write Multiple Register	Write several device parameters word by word

Function code	Name	Sub-function	Description
08 Hex	Return Query Dat	00	Send the received message back
08 Hex	Restart Communications	01	Restart communication
08 Hex	Force Listen Only Mode	04	Switch to listen-only mode

11.4. Parameter table

Register address	Protocol address	Parameter name	Value range	Data type	Authority
40110	109	Operating mode	0 = OFF 1 = Stage 1 2 = Stage 2 3 = Stage 3	integer	R/W
40111	110	Set-point temperature 1	minimum - maximum set point temperature in 1/10 °C	integer	R/W
40123	122	Set point humidity 1	200 - 800 corresponds to 20% - 80%	integer	R/W
40135	134	Set point volume supply air 1	FFH125/150/160: 50 - 500m³/h FFH200: 50 - 600m³/h FFH250/315: 100 - 1200m³/h	integer	R/W
40136	135	Set point volume supply air 2	FFH125/150/160: 50 - 500m³/h FFH200: 50 - 600m³/h FFH250/315: 100 - 1200m³/h	integer	R/W
40137	136	Set point volume supply air 3	FFH125/150/160: 50 - 500m³/h FFH200: 50 - 600m³/h FFH250/315: 100 - 1200m³/h	integer	R/W
40147	146	Set point pressure supply air 1	50 - 500 Pa		
40148	147	Set point pressure supply air 2	50 - 500 Pa		
40149	148	Set point pressure supply air 3	50 - 500 Pa	integer	R/W
40153	152	Set point pressure extract air 1	50 - 500 Pa	integer	R/W
40154	153	Set point pressure extract air 2	50 - 500 Pa	integer	R/W
40155	154	Set point pressure extract air 3	50 - 500 Pa	integer	R/W
40159	158	Speed, supply air, stage 1	25 - 100 25% - 100% from n-max.	integer	R/W
40160	159	Speed, supply air, stage 2	25 - 100 25% - 100% from n-max.	integer	R/W
40161	160	Speed, supply air, stage 3	25 - 100 25% - 100% from n-max.	integer	R/W
40165	164	Speed, exhaust air, stage 1	25 - 100 25% - 100% from n-max.	integer	R/W
40166	165	Speed, exhaust air, stage 2	25 - 100 25% - 100% from n-max.	integer	R/W
40167	166	Speed, exhaust air, stage 3	25 - 100 25% - 100% from n-max.	integer	R/W
40214	213	Automatic restart enable	0 = disable, 1 = enable	integer	R/W
40216	215	Save parameters	12439 Value change after saving under 0	integer	R/W

Register address	Protocol address	Parameter name	Value range	Data type	Authority
40233	232	Min. set point temp. heating	Temp. in 1/10°C 100-200	integer	R/W
40234	233	Max. set point temp. heating	Value changes to 0 after saving	integer	R/W
40262	261	Delta P supply air filter 1	50 - 200 Pa	integer	R/W
40273	272	Modbus address	1-240	integer	R/W
40274	273	Modbus baud rate	0 = 0, 1 = 2400, 2 = 4800, 3 = 9600, 4 = 14400, 5 = 19200, 6 = 28800, 7 = 38400, 8 = 57600	integer	R/W
40275	274	Modbus parity	0 = 8N1, 1 = 8N2, 2 = 8E1 (Even), 3 = 8O1 (Odd)	integer	R/W
40290	289	Fan control type	0 = Speed step control, 1 = Pressure control, 2 = Constant volume flow control, 3 = External control, 4 = Sensor	integer	R/W
40303	302	Temperature control type	0 - 1, 0 = Supply air temperature, 1 = Room temperature	integer	R/W
40308	307	Heating capacity E-heating	0 - 3 FFH 125/150/160: 1 = 1,5kW; 2 = 3kW FFH 200: 1 = 1,5kW; 2 = 3kW; 3 = 4,5kW FFH 250/315: 1 = 3kW; 2 = 6kW; 3 = 9kW	integer	R/W
40401	400	Set 1 Switching point 1	0000-2355 (e.g. hour 7:30 = 0730)	integer	R/W
40402	401	Set 1 Switching point 2		integer	R/W
40403	402	Set 1 Switching point 3		integer	R/W
40404	403	Set 1 Switching point 4		integer	R/W
40405	404	Set 1 Switching point 5		integer	R/W
40406	405	Set 1 Switching point 6		integer	R/W
40407	406	Set 2 Switching point 1		integer	R/W
40408	407	Set 2 Switching point 2		integer	R/W
40409	408	Set 2 Switching point 3		integer	R/W
40410	409	Set 2 Switching point 4		integer	R/W
40411	410	Set 2 Switching point 5		integer	R/W
40412	411	Set 2 Switching point 6		integer	R/W
40413	412	Set 3 Switching point 1		integer	R/W
40414	413	Set 3 Switching point 2		integer	R/W
40415	414	Set 3 Switching point 3		integer	R/W
40416	415	Set 3 Switching point 4		integer	R/W
40417	416	Set 3 Switching point 5		integer	R/W
40418	417	Set 3 Switching point 6		integer	R/W
40419	418	Set 4 Switching point 1		integer	R/W
40420	419	Set 4 Switching point 2		integer	R/W
40421	420	Set 4 Switching point 3		integer	R/W
40422	421	Set 4 Switching point 4		integer	R/W
40423	422	Set 4 Switching point 5		integer	R/W
40424	423	Set 4 Switching point 6		integer	R/W
40425	424	Set 5 Switching point 1		integer	R/W
40426	425	Set 5 Switching point 2		integer	R/W
40427	426	Set 5 Switching point 3		integer	R/W
40428	427	Set 5 Switching point 4		integer	R/W
40429	428	Set 5 Switching point 5		integer	R/W
40430	429	Set 5 Switching point 6		integer	R/W
40431	430	Set 6 Switching point 1		integer	R/W
40432	431	Set 6 Switching point 2		integer	R/W
40433	432	Set 6 Switching point 3		integer	R/W
40434	433	Set 6 Switching point 4		integer	R/W
40435	434	Set 6 Switching point 5		integer	R/W

Register address	Protocol address	Parameter name	Value range	Data type	Authority
40436	435	Set 6 Switching point 6		integer	R/W
40437	436	Set 7 Switching point 1		integer	R/W
40438	437	Set 7 Switching point 2		integer	R/W
40439	438	Set 7 Switching point 3		integer	R/W
40440	439	Set 7 Switching point 4		integer	R/W
40441	440	Set 7 Switching point 5		integer	R/W
40442	441	Set 7 Switching point 6		integer	R/W
40501	500	Set 1 Modus 1	0 - 3; 0 = Off, 1 = Stage 1, 2 = Stage 2, 3 = Stage 3	integer	R/W
40502	501	Set 1 Modus 2		integer	R/W
40503	502	Set 1 Modus 3		integer	R/W
40504	503	Set 1 Modus 4		integer	R/W
40505	504	Set 1 Modus 5		integer	R/W
40506	505	Set 1 Modus 6		integer	R/W
40507	506	Set 2 Modus 1		integer	R/W
40508	507	Set 2 Modus 2		integer	R/W
40509	508	Set 2 Modus 3		integer	R/W
40510	509	Set 2 Modus 4		integer	R/W
40511	510	Set 2 Modus 5		integer	R/W
40512	511	Set 2 Modus 6		integer	R/W
40513	512	Set 3 Modus 1		integer	R/W
40514	513	Set 3 Modus 2		integer	R/W
40515	514	Set 3 Modus 3		integer	R/W
40516	515	Set 3 Modus 4		integer	R/W
40517	516	Set 3 Modus 5		integer	R/W
40518	517	Set 3 Modus 6		integer	R/W
40519	518	Set 4 Modus 1		integer	R/W
40520	519	Set 4 Modus 2		integer	R/W
40521	520	Set 4 Modus 3		integer	R/W
40522	521	Set 4 Modus 4		integer	R/W
40523	522	Set 4 Modus 5		integer	R/W
40524	523	Set 4 Modus 6		integer	R/W
40525	524	Set 5 Modus 1		integer	R/W
40526	525	Set 5 Modus 2		integer	R/W
40527	526	Set 5 Modus 3		integer	R/W
40528	527	Set 5 Modus 4		integer	R/W
40529	528	Set 5 Modus 5		integer	R/W
40530	529	Set 5 Modus 6		integer	R/W
40531	530	Set 6 Modus 1		integer	R/W
40532	531	Set 6 Modus 2		integer	R/W
40533	532	Set 6 Modus 3		integer	R/W
40534	533	Set 6 Modus 4		integer	R/W
40535	534	Set 6 Modus 5		integer	R/W
40536	535	Set 6 Modus 6		integer	R/W
40537	536	Set 7 Modus 1		integer	R/W
40538	537	Set 7 Modus 2		integer	R/W
40539	538	Set 7 Modus 3		integer	R/W
40540	539	Set 7 Modus 4		integer	R/W
40541	540	Set 7 Modus 5		integer	R/W
40542	541	Set 7 Modus 6		integer	R/W

11.5. Current value table

Register address	Protocol address	Parameter name	Value range	Data type	Authority
30111	110	Unit identification		integer	R
30112	111	Room temperature	Temp in 1/10 °C - 500 to 1000	integer	R
30113	112	Supply-air temperature	Temp in 1/10 °C - 500 to 1000	integer	R
30118	117	Pressure-difference, filter 1	0-1000 Pa in 1/10 Pa	integer	R
30122	121	Soiling indicator 1	0-100 % in 1/10 %	integer	R
30127	126	CO2 value		integer	R
30128	127	VOC value		integer	R
30130	129	Humidity supply air		integer	R
30131	130	Pressure difference supply air fan	0-1000 Pa in 1/10 Pa	integer	R
30133	132	Volume flow supply air fan		integer	R
30135	134	Duct pressure supply air	-1000 up to 1000 Pa	integer	R
30136	135	Duct pressure extract air	-1000 up to 1000 Pa	integer	R
30139	138	Control heating	0-100%	integer	R
30152	151	Error number	see error table	integer	R
30154	153	Program version 1		integer	R
30155	154	Program version 2		integer	R
30156	155	Operating hours	h/10	integer	R
30157	156	Filter change 1		integer	R
30161	160	Filter operating hours	h/10	integer	R



12. Expansion and reconfiguration

The unit must not be reconfigured.

Maico Ventilatoren's warranty only applies for the configuration delivered. The warranty will cease to apply after any reconfiguration or expansion.

13. Dismantling and disposal



- **Risk of injury if dismantled under hazardous voltage!**
- » **If you do not switch off the voltage before starting to dismantle the unit you may injure yourself and damage the product or parts of the installation.**
- **Make sure that the relevant parts of the installation have been disconnected from the voltage supply.**

Dismantle the unit as follows:

13.1. Disassembling the product.

Observe the safety instructions given in Sections 2 to 8 and Section 12 when decommissioning and disassembling the unit.

13.2. Disposal

Careless disposal of the unit may cause pollution.

Please therefore dispose of the unit in accordance with the national requirements that apply in your country.

14. Troubleshooting

Please note the following instructions:

- Proceed systematically and purposefully when troubleshooting, even when under the pressure of time. In the worst case, randomly and indiscriminately dismantling and changing settings may result in it no longer being possible to determine the original cause of the fault.
- Get an overview of the unit's operation in conjunction with the overall installation.
- Try to clarify whether the unit provided the required function in the overall installation before the fault occurred.
- Try to find any changes to the overall installation in which the unit is installed:
 - » Have the unit's operating conditions or operating range been changed?
 - » Have any changes (e.g. reconfigurations) or repairs been performed on the overall system (installation, electrics, control) or to the unit? If yes: what?
 - » Has the unit been operated correctly?
 - » How does the fault appear?
- Form a clear idea of the cause of the fault. If necessary, question the immediate operator or the installation operator.



If you have not been able to remove the fault, please contact the manufacturer. The contact address can be found at www.maico.de or on the back cover of this operating and installation manual.

14.1. Low-current fuses

To protect the electrical equipment there are two low-current fuses in the unit (see Fig. 16.). When a fuse blows for the first time, this may be due to ageing. In this case we recommend replacing the defective fuse with a new one.

If the fuse blows again, the fault can be located and repaired using the following chart. A low-current fuse must be changed by specialist personnel.

The low-current fuses must comply with EN 60127, dimensions 5 x 20 mm.

Fuse	Possible causes	Fault correction
F1 / T 6,3 A	<ul style="list-style-type: none"> • Damper drive or lead defect. • Damper drive defect. 	<ul style="list-style-type: none"> • Replace lead. • Replace damper drive.

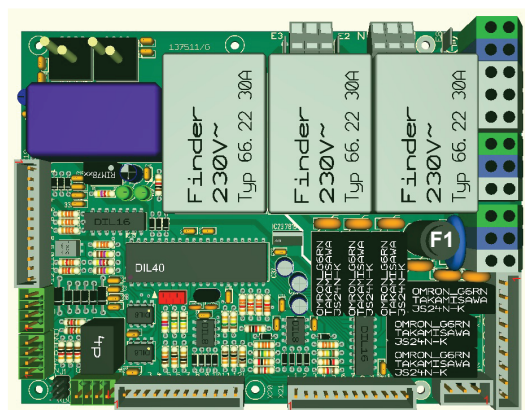

Fig. 16:
Board with low-current fuses F1.

14.2. Fault diagnosis chart

If a fault occurs on the unit one or more fault messages will appear on the display. Move between the various faults with buttons A (▲ and ▼). A fault is acknowledged with button B (▲). It is not possible to use the control unit until all of the faults have been removed and acknowledged. Depending on the priority of the fault, the installation will either switch off or continue working with the last settings. The following faults might be shown on the display:



Faults displayed	Type of fault and repair
ERR	<p>ERROR</p> <ul style="list-style-type: none"> » The control unit has no reception. » Check the connection or replace the cable if necessary.
F1 FAULT SUPPLY AIR TEMP	<p>Supply air temperature sensor fault</p> <ul style="list-style-type: none"> » The supply air temperature sensor is defective or the cable is broken. » Replace the defective temperature sensor or replace the broken cable if necessary. » After removing the cause of the fault, the fault must be acknowledged with button B (▲).
F2 FAULT ROOM TEMPERATURE	<p>Room temperature sensor fault.</p> <ul style="list-style-type: none"> » The room temperature sensor is defective or the cable is broken. » Replace defective control unit or lead as appropriate. » After removing the cause of the fault, the fault must be acknowledged with button B (▲).
F8 FAULT SAFTY THERMOSTAT	<p>Fault in the safety thermostat - electric heating element temperature monitoring.</p> <ul style="list-style-type: none"> » The housing temperature is higher than 75 °C. The control circuit is broken, the electric heater is switched off. Possible cause: defective supply air valve, fan has failed, etc. » Repair supply air valve, check fuses F2. » Once the cause of the fault has been removed, the reset button on the safety thermostat (see Fig. 11) must be reset manually and the fault must be acknowledged on the control unit with button B (▲).
F10 FAULT FAN	<p>Error fan</p> <ul style="list-style-type: none"> » A signalling relays of a fan has been tripped. <p>F10 = Supply air fan terminal X20.6 F₁₀ = Extract air fan terminal X21.6</p> <ul style="list-style-type: none"> » Switch the unit off, check wiring and fans and if needed, replace damaged fan. » Cause of error: Power supply, fuse, wiring, motor control, frequency converter, motor defect » After removing the cause of the fault, the fault must be acknowledged with button B (▲).
NOT ENABLE	<p>No release</p> <ul style="list-style-type: none"> » The release contact is not closed. » Close the release contact. The unit can then be started.



14.3. Possible operating faults.

Further faults may occur before and during operation of the unit which are not indicated by an error message on the display.

Faults	Possible causes	Fault correction
Fan does not run.	<ul style="list-style-type: none"> • Unit not switched on. • No electricity supply • Supply lead not connected. 	<ul style="list-style-type: none"> • Switch unit on. • Check fuse / supply • Have the supply lead connected by an electrician. • Allow fan motor to cool.
Airflow to low.	<ul style="list-style-type: none"> • Thermal contact has opened. • Fan speed set to slow. • Airway obstructed • Filter clogged 	<ul style="list-style-type: none"> • Set the fan speed higher. • Ensure that the air ducts are unobstructed. • Change filter
Draughts	<ul style="list-style-type: none"> • Fan speed set to high. • Blown air temperature too low. 	<ul style="list-style-type: none"> • Set the fan speed lower. • Increase the temperature setting on the regulator.
Unit to noisy.	<ul style="list-style-type: none"> • Fan speed set to high. • Air outlet obstructed, causing air noises. • Fan bearing noise. • Filter clogged 	<ul style="list-style-type: none"> • Select a lower speed setting. • Free the air ducts of restrictions and direction changes. • Inform specialist company / service • Change filter

15. Technical data

Specifications			ECR 12-2 EC	ECR 15-2 EC	ECR 16-2 EC	ECR 20-2 EC	ECR 25-2 EC	ECR 31-2 EC
Units / Model			153230	153233	153236	153240	153377	153380
Length	<i>L</i>	<i>mm</i>	718	718	718	718	718	718
	<i>L 1</i>	<i>mm</i>	760	760	760	760	760	760
	<i>L 2</i>	<i>mm</i>	712	712	712	712	712	712
Width	<i>B</i>	<i>mm</i>	406	406	406	406	466	466
	<i>B 1</i>	<i>mm</i>	478	478	478	478	538	538
	<i>B 2</i>	<i>mm</i>	399	399	399	399	459	459
	<i>B 3</i>	<i>mm</i>	323	323	323	323	323	323
Height <i>without holder</i>	<i>H</i>	<i>mm</i>	346	346	346	346	406	406
Nominal width	<i>NW</i>	<i>mm</i>	125	150	160	200	250	315
Weight		<i>kg</i>	25,1	24,8	24,7	24,2	37,8	36,7
Operating voltage	<i>V</i>		230V ~	230V ~	230V ~	400V 3~N	400V 3~N	400V 3~N
Frequency	<i>Hz</i>		50	50	50	50	50	50
Power consumption	<i>W</i>		3000	3000	3000	4500	9000	9000
Maximum current	<i>A</i>		13,9	13,9	13,9	7,4	14,5	14,5
Current fan	<i>A</i>		0,82	0,82	0,85	0,83	1,41	1,38
Protection			1 x 16A	1 x 16A	1 x 16A	3 x 16A	3 x 16A	3 x 16A
Max. medium temp.	<i>°C</i>		40	40	40	40	40	40
Max. air volume	<i>m³/h</i>		500	570	580	620	1190	1200
RPM	<i>1/min</i>		3380	3370	3360	3360	2585	2570
Max. pressure	<i>Pa</i>		625	625	620	630	655	660
Sound intake air	<i>dB</i>		62	64	65	66	71	72
Sound outlet air	<i>dB</i>		66	68	69	69	69	71
Fan stage			3	3	3	3	3	3
Filter grade (Z-line)			M5	M5	M5	M5	M5	M5
Wiring diagrams			153225	153225	153225	153225	153225	153225
Control unit								
Size	<i>B+H+T</i>	<i>mm</i>	82+82+30	82+82+30	82+82+30	82+82+30	82+82+30	82+82+30
Assembly size	$\varnothing B$	<i>mm</i>	60	60	60	60	60	60
	$\varnothing D$	<i>mm</i>	22	22	22	22	22	22

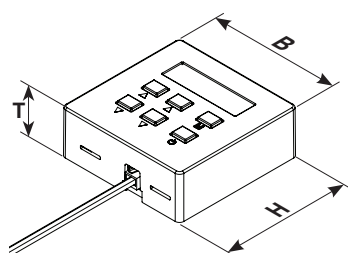

Fig. 17:
Outside dimensions of the control unit.

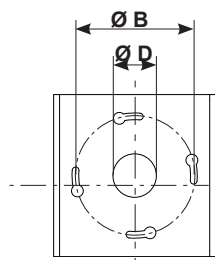

Fig. 18:
Installation dimensions of the control unit.

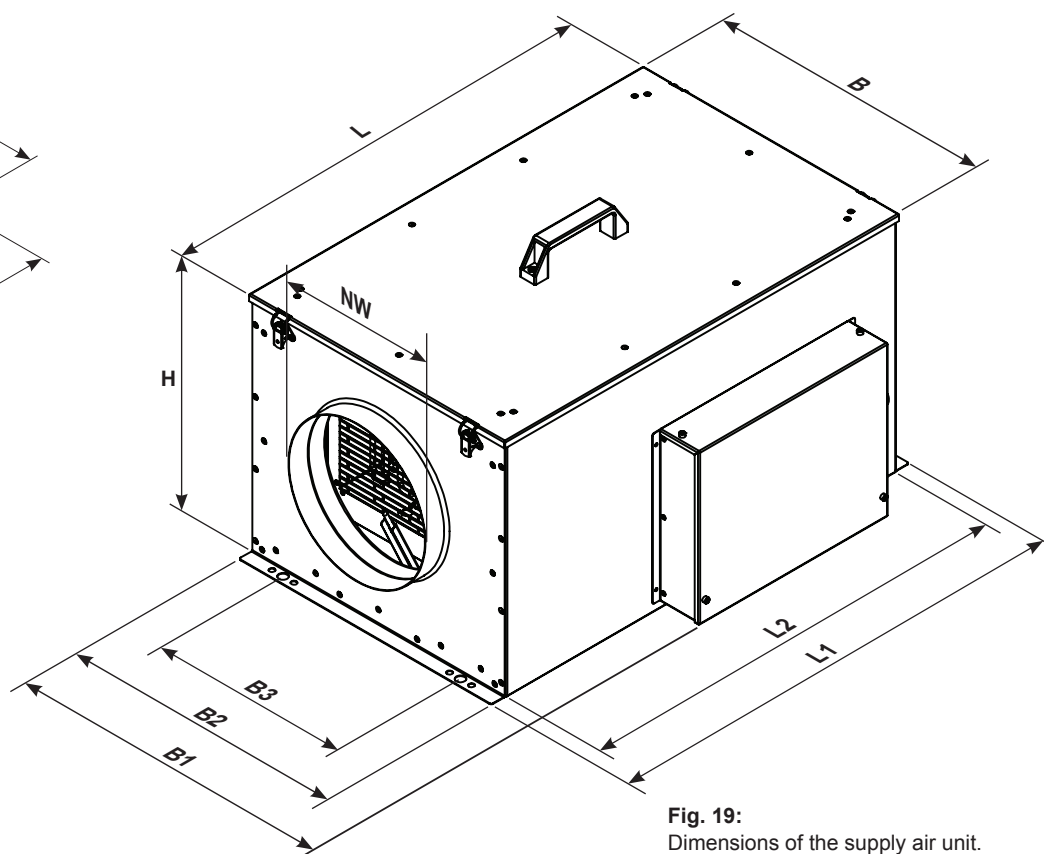

Fig. 19:
Dimensions of the supply air unit.

153225
ECR 20-2 EC

Netzspannung / Mains voltage : 400V / 3~ / N / 50Hz

Leistung / Power : 4,5kW

Vorsicherung / Fuse : 3 x 16A

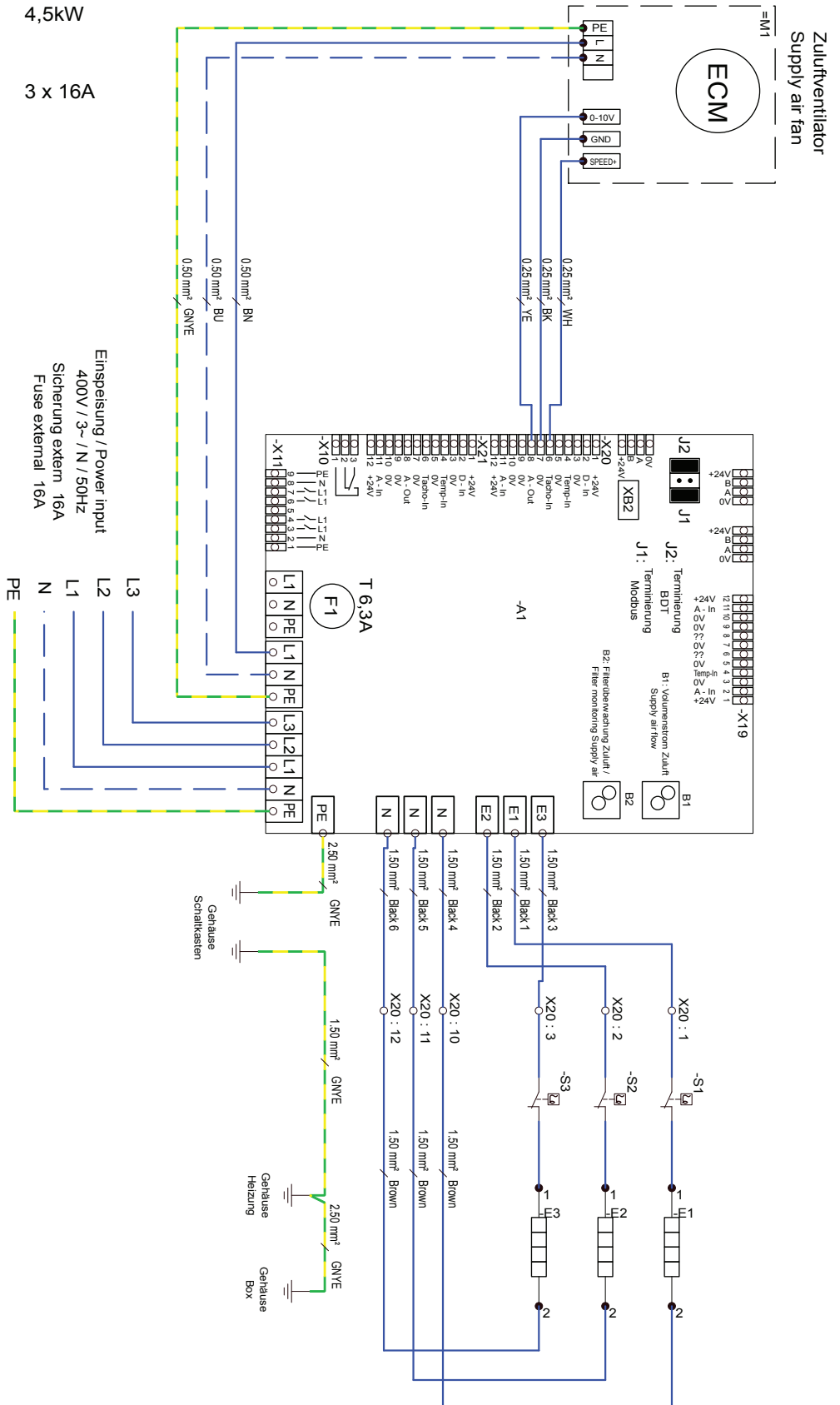

153225
ECR 25-2 EC / ECR 31-2 EC

Netzspannung : 400V / 3~ / N / 50Hz
 Mains voltage

Leistung : 9kW
 Power

Vorsicherung : 3 x 16A
 Fuse

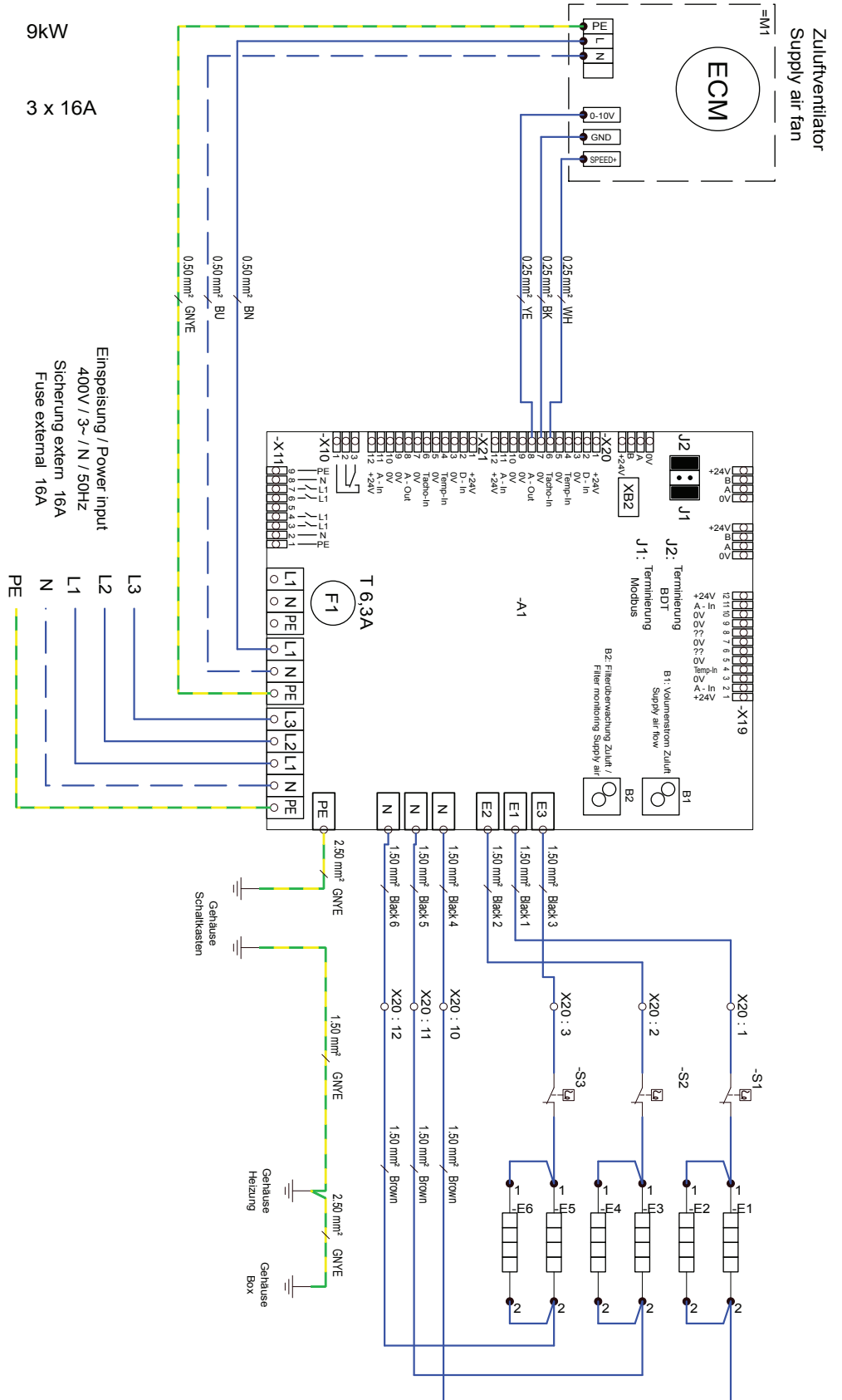

Einspeisung / Power input
 400V / 3~ / N / 50Hz
 Sicherung extern 16A
 Fuse external 16A

Connection external extract fan

Meldungsquelle: Tacho Signal oder Open-collector
 malfunktion-source: speed-signal or open-collector

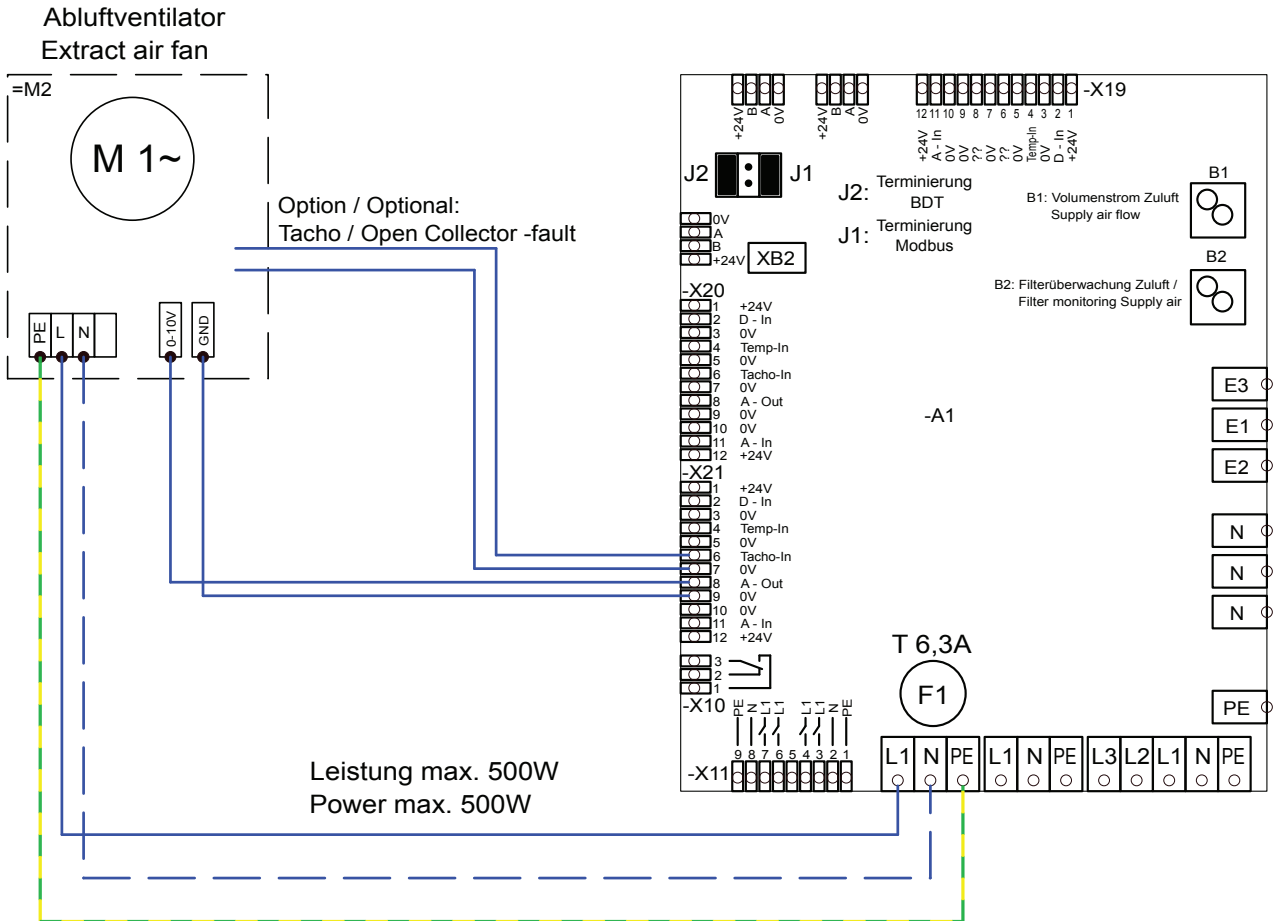

Connection pressure sensor for constant pressure control

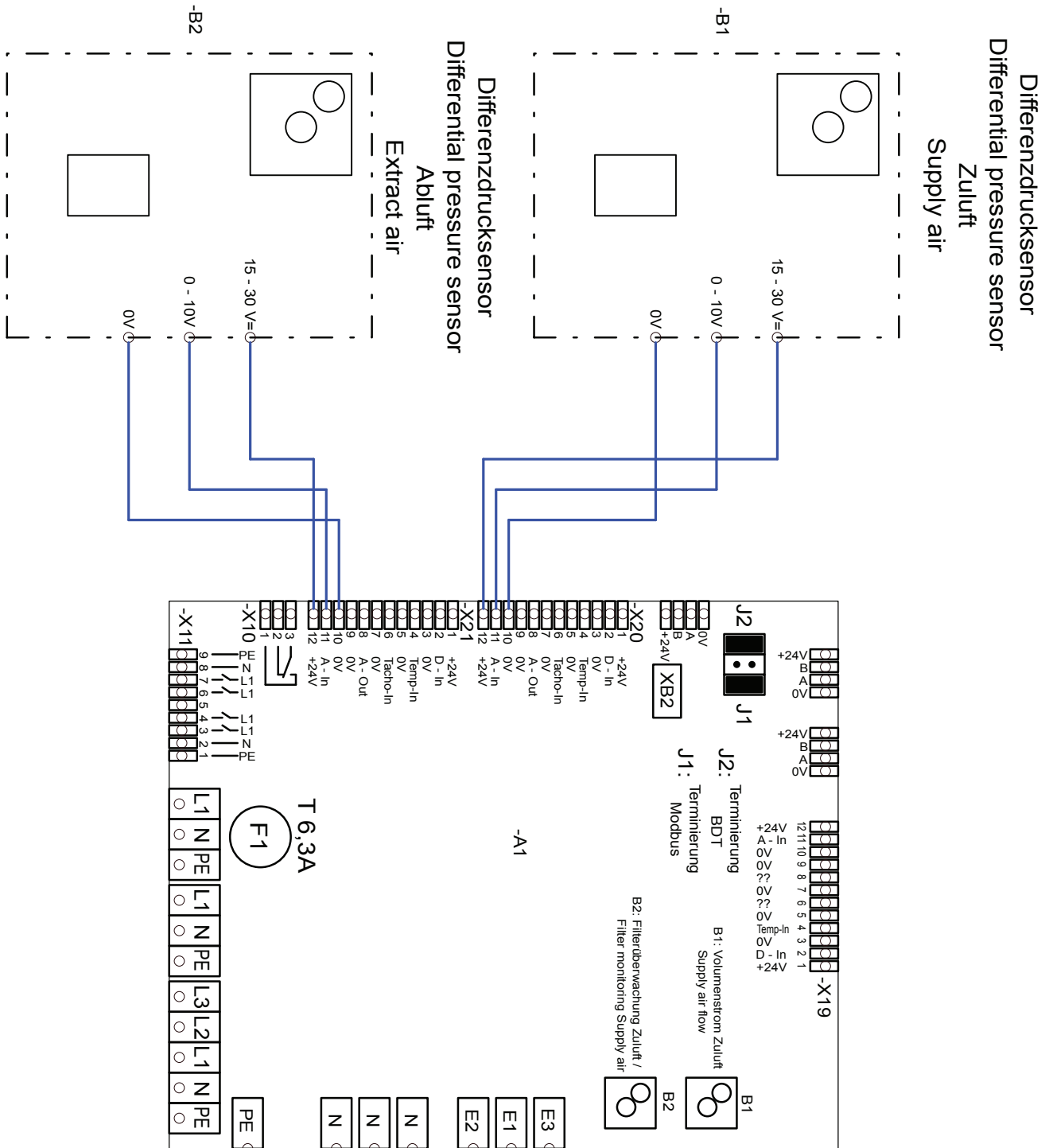

External sensor (CO2, VOC)

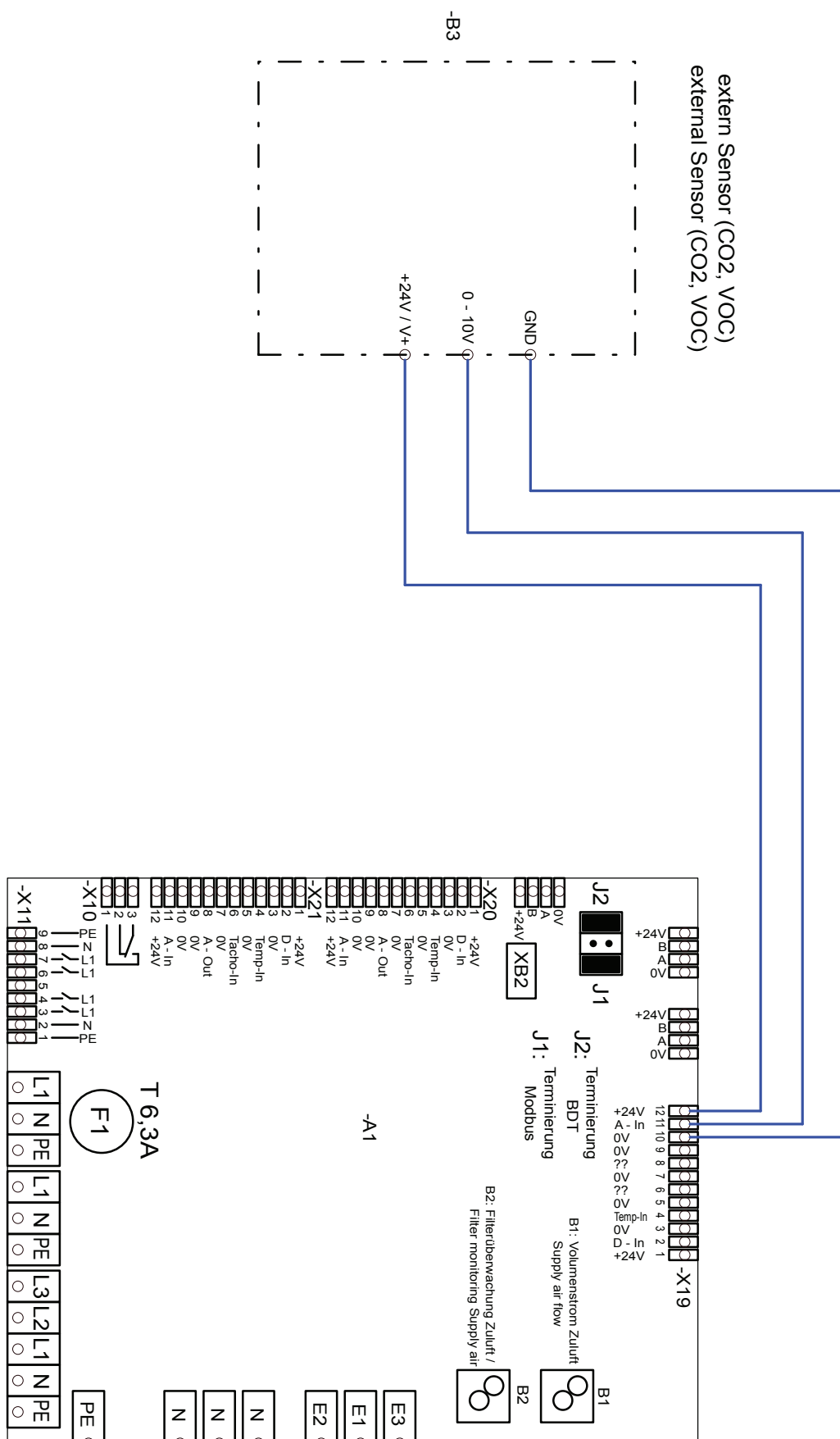

Connection for external control

10V: max. Ventilator Drehzahl
 2V : min. Ventilator Drehzahl
 <2V: Gerät Aus

GND
 0-10V

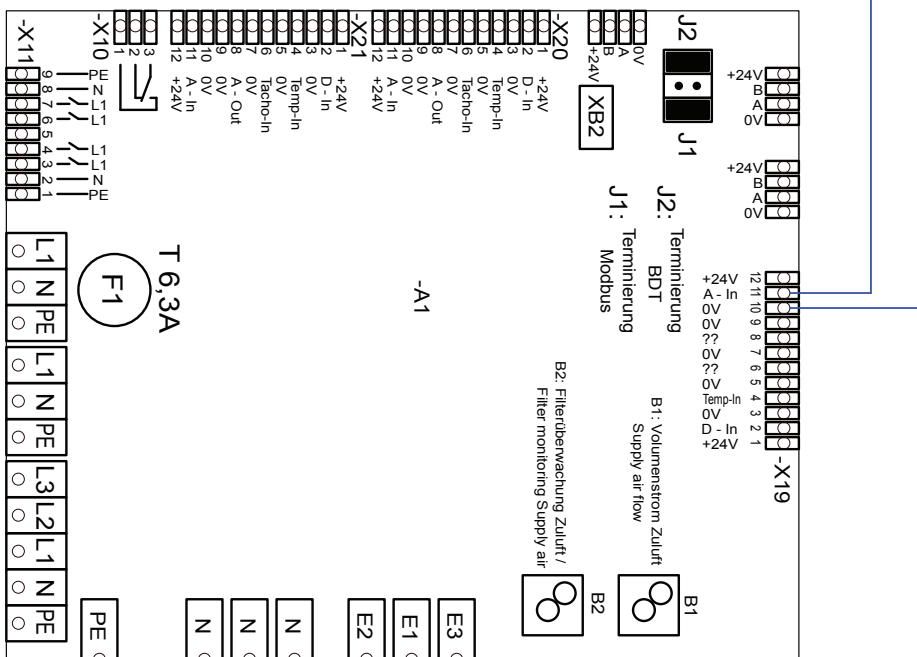

Maico

Elektroapparate-Fabrik GmbH

Steinbeisstraße 20

D - 78056 Villingen-Schwenningen

Tel. +49 7720 694 0

Fax. +49 7720 694 263

info@maico.de

www.maico.de

The data specified above only serve to describe the product. No statements concerning a certain condition or suitability for a certain application can be derived from our information.

The information given does not release the user from the obligation of own judgment and verification.

It must be remembered that our products are subject to a natural process of wear and aging.

This document, as well as the data, specifications and other information set forth in it, are the exclusive property of **Maico**.

It may not be reproduced or given to third parties without its consent.

Information updated:
print 03.04.2023
mzf_pb_04c_k11102_en

We reserve the right to make changes

English