

WIRING DIAGRAM

DHP 22-9

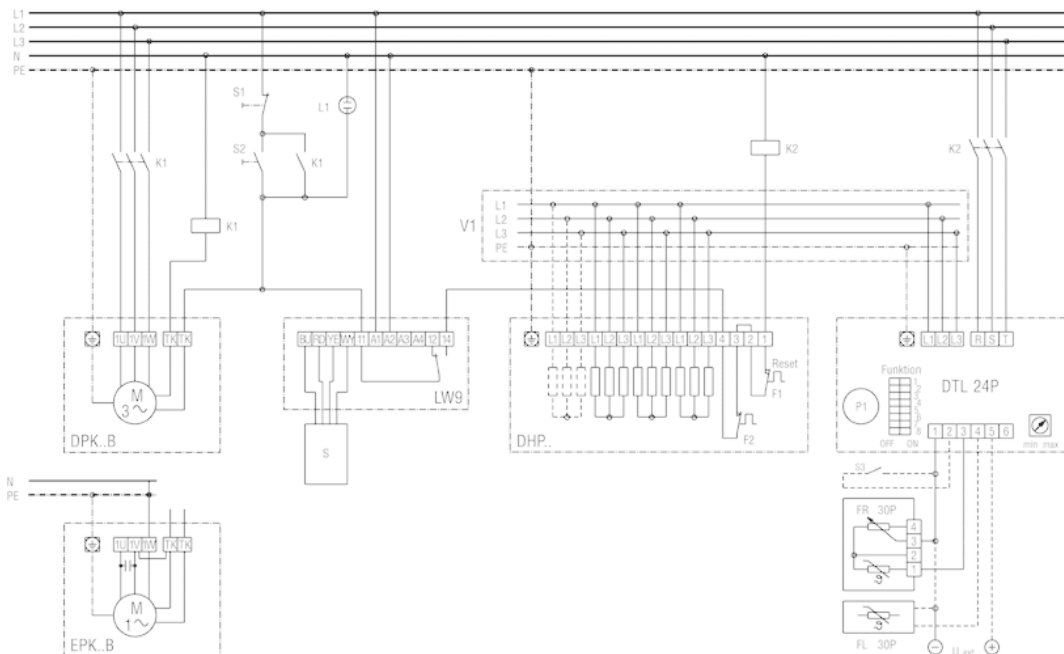

DHP 22-9 with EPK / DPK and DTL 24 P



- S1 - system off
- S2 - system on
- L1 - control light system on
- K1 - contactor US 16
- K2 - contactor to be supplied by the customer
- DPK..B - centrifugal fan, DPK model series
- EPK..B - centrifugal fan, EPK model series
- LW 9 - air flow monitor (relay picks up with air flow)
- DHP.. - air heater DHP 22-9, 22-16, 25-16, 28-16, 31-16
- F1 - temperature limiter
- F2 - safety temperature limiter
- S - sensor

WIRING DIAGRAM

DHP 22-9



DHP 22-9 with EPK / DPK and DTL 24 P

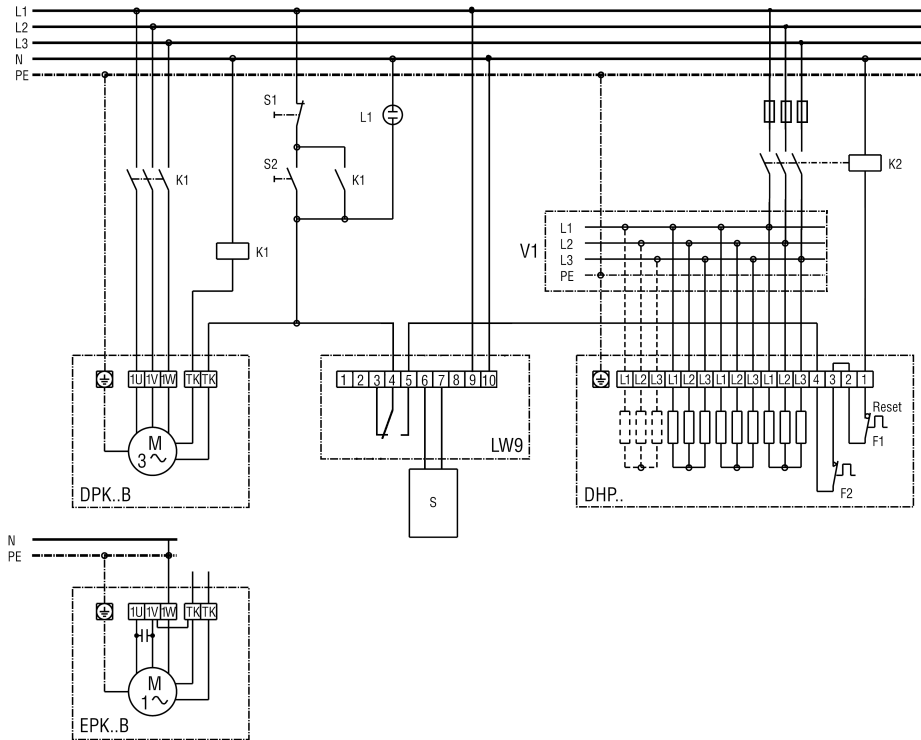

S1 - system off

S2 - system on

L1 - control light system on

K1 - contactor US 16

K2 - contactor to be supplied by the customer

DPK..B - centrifugal fan, DPK model series

EPK..B - centrifugal fan, EPK model series

LW 9 - air flow monitor (relay picks up with air flow)

DHP.. - air heater DHP 22-9, 22-16, 25-16, 28-16, 31-16

F1 - temperature limiter

F2 - safety temperature limiter

S - sensor